

Beyond the classical Cauchy-Born rule

Andrea Braides*

SISSA, via Bonomea 265, Trieste, Italy

Andrea Causin and Margherita Solci

DADU, Università di Sassari

piazza Duomo 6, 07041 Alghero (SS), Italy

Lev Truskinovsky

PMMH, CNRS - UMR 7636 PSL-ESPCI,

10 Rue Vauquelin, 75005 Paris, France

Abstract

Physically motivated variational problems involving non-convex energies are often formulated in a discrete setting and contain boundary conditions. The long-range interactions in such problems, combined with constraints imposed by lattice discreteness, can give rise to the phenomenon of geometric frustration even in a one-dimensional setting. While non-convexity entails the formation of microstructures, incompatibility between interactions operating at different scales can produce nontrivial mixing effects which are exacerbated in the case of incommensurability between the optimal microstructures and the scale of the underlying lattice. Unraveling the intricacies of the underlying interplay between non-convexity, non-locality and discreteness, represents the main goal of this study. While in general one cannot expect that ground states in such problems possess global properties, such as periodicity, in some cases the appropriately defined ‘global’ solutions exist, and are sufficient to describe the corresponding continuum (homogenized) limits. We interpret those cases as complying with a Generalized Cauchy-Born (GCB) rule, and present a new class of problems with geometrical frustration which comply with GCB rule in one range of (loading) parameters while being strictly outside this class in a complementary range. A general approach to problems with such ‘mixed’ behavior is developed.

1 Introduction

Variational problems emerging from applications are often both discrete and non-convex. Important examples include one-dimensional boundary-value problems with translation-invariant

*Data availability statement: manuscript has no associated data

*corresponding author. E-mail address: braides@mat.uniroma2.it. ORCID ID: 0000-0003-1612-2785

energy densities describing pairwise interactions. Such problems constitute the main subject of this paper.

The representative energies for this class of problems can be written in the following generic form

$$F(w; k) = \min \left\{ \sum_{i,j=0}^k f_{i-j}(u_i - u_j) : u_0 = 0, u_k = w \right\}, \quad (1.1)$$

where for every n natural number f_n is a potentially nonconvex energy governing interactions between the lattice points at distance n , and the minimum is searched among $k + 1$ -arrays (u_0, \dots, u_k) . We may assume that $f_0 = 0$. As the parameter k increases and more interactions are taken into account, a question arises about the behavior of minimal arrays (u_0^k, \dots, u_k^k) and of the corresponding minimal energy. One of the most important issues concerns the existence of a continuum limit of the type $F_{\text{hom}}(u) = \int_I f_{\text{hom}}(u') dt$, with I an interval in which the nodes i in (1.1) are identified as a discrete subset (e.g., $I = [0, 1]$ where the discrete subset is $\frac{1}{k}\mathbb{Z} \cap [0, 1]$). The single function f_{hom} is expected to carry, in a condensed way, all the relevant information about the infinite set of functions f_n from (1.1).

To track the asymptotic behavior of the minimum values in (1.1) we can use the average derivative $z = w/k$ as a parameter, and scale the energy by k . Then, under assumptions on a suitably fast decay of f_n with respect to n , it can be shown that the limiting energy density f_{hom} exists and can be expressed by the formula

$$f_{\text{hom}}(z) = \lim_{k \rightarrow +\infty} \frac{1}{k} \min \left\{ \sum_{i,j=0}^k f_{i-j}(u_i - u_j) : u_0 = 0, u_k = kz \right\}. \quad (1.2)$$

Moreover, it can be shown that the function f_{hom} is convex in the parameter z . This result represents a particular case of a more general variational theory for limits of lattice energies (see e.g. [3]); it can be also seen as a zero-temperature limit of the analogous result in Statistical Physics ([93, 91]). However, formula (1.2) is only a formal homogenization result in a discrete-to-continuum setting which is usually non-constructive. In this paper we are raising the issue of the actual *computability* of $f_{\text{hom}}(z)$.

Explicit formulas for $f_{\text{hom}}(z)$ in terms of f_n are known only in few cases, most of which are mentioned below. In general, it is known that the behavior of minimizing arrays (u_0^k, \dots, u_k^k) at fixed z , may be complex, including equi-distribution ('crystallization'; see e.g. [75]), periodic oscillations [27, 56], development of discontinuities (fracture in lattice models [96, 30]) or defects (internal boundary layers [25]).

A robust approach to the computation of $f_{\text{hom}}(z)$ is known under the name of *Cauchy-Born (CB) rule* and is applicable under some restrictive conditions ([47, 17]). It is based on the assumption that the homogenized energy can be computed using the affine interpolations $u_j = zj$ and relying *exclusively* on problems with finite k . Various sufficient conditions for the validity of the Cauchy-Born rule have been obtained by a number of authors mostly in the context of local minimizers [46, 65, 76, 88, 99, 40, 100]. While those results are usually valid

only for subsets of loading parameters, they are often applicable for dimensions higher than one. They are of considerable interest, first of all, for the development of numerical methods because the applicability of the classical CB rule makes such methods extremely efficient, even if for a limited set of boundary conditions. The difference of our approach to (1.2) is that we are interested in *global* minimization (viewed as a zero temperature limit of a statistically equilibrium response) and consider the possibility that the conventional CB rule is operative only in a *subset* of the loading parameters while in the complementary subset the CB strategy should be appropriately *generalized* or even completely ruled out.

The main reason for the failure of the classical Cauchy-Born rule is the geometrical frustration caused by incompatible optimality demands imposed by (generically non-convex and long range) potentials f_n with positive integer n and the discreteness of the lattice. More specifically, as non-convexity favors the formation of microstructures, incompatibility between interactions operating at different scales may generate nontrivial mixing effects. The latter are dramatically more pronounced in the case of incommensurability between the optimal microstructures and the scale of the underlying lattice. A detailed case study of the underlying interplay between non-convexity, non-locality and discreteness, represents the main goal of this paper.

If the classical Cauchy-Born rule fails, the natural task is to search for a nontrivial generalization of the Cauchy-Born rule. In this perspective, we pose the problem of finding the conditions for which the minimal arrays in (1.1) have ‘global’ features in the sense that solving a ‘local’ problem on a *finite* domain opens the way towards describing the limit in (1.2). More specifically, the question is whether the limiting energy $f_{\text{hom}}(z)$ can be approximately computed by solving a finite set of ‘cell’ problems modeled on (1.1) and potentially producing *non-affine* optimal configurations. The validity of the so-interpreted generalized Cauchy-Born (GCB) rule would then require that even if the implied ‘local’ problems could be solved only on some subsets of parameters, the knowledge of the corresponding solutions would ensure the recovery of the macroscopic (homogenized) energy in the *whole* range of loading parameters.

Note that in local problems like (1.1) the presence of interactions f_n with $n \in \{1, \dots, k\}$ requires k boundary conditions on each side. By fixing parametrically only the average strain z in (1.2) we effectively assume that the remaining boundary conditions are natural. This simplifying assumption may stay on the way of acquiring, for the given ‘local’ problem, the corresponding ‘global’ features. That is why we will understand the ‘local’ GCB problem as having the right boundary conditions to ensure the recovery of the macroscopic energy $f_{\text{hom}}(z)$. The simplest case is when the value of $f_{\text{hom}}(z)$ can be achieved on arrays such that $i \mapsto u_i - zi$ is periodic with a given period, but in general one should be allowed to adjust boundary conditions accordingly while keeping in mind that these changes should not affect the minimizers in an asymptotic sense.

We now illustrate the main difficulties on the way of generalizing the classical CB rule with some known cases. We start with the simplest example where the conventional CB rule works trivially. It is the case of convex nearest-neighbor (NN) interactions; i.e., when $f_n = 0$

for all $n \geq 2$, and $f_1 = f$ is a strictly convex function. In this case, the unique minimizer of the problem in (1.2) is the affine interpolation $u_j^k = zj$. It is independent of k and hence ‘global’: in this case the classical Cauchy-Born rule is applicable in its simplest form, and $f_{\text{hom}}(z) = f(z)$.

If we make the above example only a little more complex considering also convex next-to-nearest-neighbour (NNN) interactions; i.e., $f_n = 0$ for all $n \geq 3$, with f_1 and f_2 convex functions, we lose this exact characterization of the minimal arrays. However, the discrepancy between u_j^k and zj decays fast away from the endpoints $j = 0$ and $j = k$ of the array. A slight adjustment of the boundary-value problems, say by imposing additional boundary conditions $u_1 = z$ and $u_{k-1} = z(k-1)$ (which do not influence the asymptotic value of the minima in (1.2)) reestablishes the affine interpolations $u_j^k = zj$ as minimizers, so that $f_{\text{hom}}(z) = 2(f_1(z) + f_2(2z))$. In this case the classical Cauchy-Born rule is applicable, given that we modify boundary conditions in the ‘cell’ problem. Note that this analysis extends to any sufficiently fast decaying set of convex potentials f_n , giving $f_{\text{hom}}(z) = 2 \sum_{n=1}^{\infty} f_n(nz)$.

Even if we abandon the convex setting, we may still easily describe the behavior of minimum problems in (1.2) in the case of nearest-neighbor interaction, with $f_1 = f$. It can be shown that f_{hom} in (1.2) is given by the convexification f^{**} of the NN potential [28]. However the classical Cauchy-Born rule in this case has to be properly generalized. Suppose, for instance, that the potential f has a double-well form. In this case the relaxation points towards configurations containing mixtures of the two energy wells. Since in this setting there are no obstacles to simple mixing, the relaxation strategy providing f_{hom} is straightforward. Indeed, for each z there exist $z_1, z_2, \theta \in [0, 1]$ such that $f^{**}(z) = \theta f(z_1) + (1 - \theta)f(z_2)$. Hence, we can construct a function $u^z : \mathbb{Z} \rightarrow \mathbb{R}$ with $u_i^z - u_{i-1}^z \in \{z_1, z_2\}$, $u_0^z = 0$ and $|u_i^z - iz| \leq C$. Such u^z may be chosen periodic, if θ is rational, or quasiperiodic (loosely speaking, as the trace on \mathbb{Z} of a periodic function with an irrational period) otherwise. In both cases we obtain ‘local’ minimizers with ‘global’ properties which allows one to talk about the applicability of the GCB rule.

The situation is more complex in the case when non-convexity is combined with frustrated (incompatible) interactions. To show this effect in the simplest setting it is sufficient to account for nearest-neighbor and next-to-nearest-neighbor interactions only and we make the simplest nontrivial choice by assuming that f_1 is a ‘double-well’ potential and that f_2 is a convex potential. In this case the homogenized potential f_{hom} is also known explicitly [27, 86]. Its domain can be subdivided in three zones: two zones of ‘convexity’ where minimizers are trivial (as for convex potentials) and a zone where (approximate) minimizers in (1.2) are two-periodic functions with $u_i^z - u_{i-1}^z \in \{z_1, z_2\}$ and $z_1 + z_2 = z$ (in a sense, a constrained non-convex case as above). Hence, in these three zones we have minimizers with a ‘global’ form because the macroscopic energy can be obtained by solving elementary ‘cell’ problems.

One can say that in the two zones of ‘convexity’ the classical CB rule is applicable. In the ‘two-periodic’ third zone we see that the homogeneity of the minimizers is lost but an appropriately augmented GCB rule still holds. For the remaining values of z no ‘local’ GCB rule is applicable since in those cases the unique (up to reflections) minimizer is a ‘two-phase’

configuration with affine and two-periodic minimizers coexisting while being separated by a single ‘interface’ [25]. The frustration (incompatibility) manifests itself in this case through the impossibility of the penalty-free accommodation of next-to-nearest interactions across such an internal boundary layer. As a consequence, as k diverges, such minimizers tend to an affine interpolation between the ‘convex’ and ‘oscillating’ zones which delivers the correct value of $f_{\text{hom}}(z)$ without being a solution of any finite ‘cell’ problem. Effectively, the ‘representative cell’ in this case has an infinite size and therefore no GCB-type ‘local’ description of the macroscopic state is available. A somewhat similar situation is encountered in continuum homogenization of both random [70] and strongly nonlinear [26, 82] elastic composites.

In what follows, we interpret the loss of ‘locality’ in homogenization problems, which was illustrated above on the simplest example, as a failure of the GCB rule. To shed some light on the mechanism of this phenomenon, we consider below a class of analytically transparent discrete problems combining nonconvexity with geometrical frustration.

More specifically, given the complexity of a general asymptotic analysis for even one-dimensional problems of this type, we limit our attention to a class of discrete functionals of type (1.1) with

$$f_1(z) = \frac{1}{2}f(z) + m_1z^2, \quad f_n(z) = f_{-n}(z) = m_nz^2 \text{ for } n \geq 2, \quad (1.3)$$

where the function $f(z)$ is non-convex. The coefficients m_n which introduce nonlocality and frustration, are assumed to be non negative and sufficiently integrable. In other words, we suppose that the non-convexity is ‘localized’ in the nearest-neighbor interactions, while all other interactions are quadratic. The positivity of the infinite sequence $\mathbf{m} = \{m_n : n \geq 1\}$ is chosen to ensure that the implied quadratic ‘penalty’ is a measure of the distance of the configuration u_i from the affine configuration $L_z(i) = zi$ and can be then seen as a *non-local version* of the gradient of $u - L_z$. Using a terminology borrowed from Statistical Mechanics, one can also say that such penalization brings anti-ferromagnetic-type (favoring oscillations) interactions, see for instance [72]; an alternative and more conventional , ferromagnetic-type (prohibiting oscillations) quadratic penalty, was considered, for instance, in a similar discrete setting in [92].

To provide a mechanical justification for our choice of f_n we note that recently considerable efforts have been focused on the study of pattern formation induced by instabilities in structures with non-convex energy that are reinforced by elastic environments [85]. The complexity of the resulting segmentation patterns originates from the presence of competing incommensurate interactions. For instance, the non-convexity of the elastic energy of brittle springs in a linear chain drives the system towards strain localization, while the elastic background with convex energy favors homogeneity. Under quasi-static loading the elastic subsystem carries the load, while the brittle subsystem fractures sequentially with emerging discontinuities forming an intricate segmentation pattern. Typical continuum examples include cracking of drying mud, fragmentation of thin coatings and rupture of fibres in elastic

matrices [66, 19, 98]. Conceptually similar discrete phenomena take place during drying-induced hierarchical self-assembly in nano-bristle assemblages, from carbon nanotube forests to gecko feet hairs, during the formation of vertebra and during self-organization of sarcomeres in skeletal muscles [87, 55, 38, 97, 84]. Many of the discrete systems of this type were shown to exhibit remarkably complex locking on particular patterns, which could be reached and maintained reliably. In an attempt to elucidate the origin of such locking phenomena, we essentially consider a prototypical one-dimensional scalar model. Taken literally, the model describes a simple mechanical chain of multi-stable springs linked elastically by long-range unbreakable elastic springs [80].

The main mathematical advantage of a choice of f_n as in (1.3) is that the ensuing problem can exhibit both ‘local’ (GCB) and ‘global’ behavior depending on the structure of the sequence of scalar parameters m_n . Therefore our goal will be to use the chosen class of functionals to characterize the difference between CB, GCB and non-GCB problems in terms of such sequences. We show that in this naturally limited but still sufficiently rich framework one can *precisely* specify the factors preventing the GCB-type description of the macroscopic energy and pointing instead towards the non-GCB nature of the minimizers. Moreover, the considered example allow us to *abstract* some general technical tools which can facilitate the detection and the characterization of the non-GCB asymptotic behavior in more general minimization problems.

We reiterate that even in the absence of an adequate ‘cell’ problem, the ensuing value of $f_{\text{hom}}(z)$ is fully determined by the homogenization formula which in our case takes the form $f_{\text{hom}}(z) = \widehat{Q}_{\mathbf{m}}f(z)$ where

$$\widehat{Q}_{\mathbf{m}}f(z) = \lim_{k \rightarrow +\infty} \frac{1}{k} \min \left\{ \sum_{i=1}^k f(u_i - u_{i-1}) + \sum_{i,j=0}^k m_{i-j} (u_i - u_j)^2 : u_0 = 0, u_k = kz \right\}. \quad (1.4)$$

The nontrivial part of the mapping $\widehat{Q}_{\mathbf{m}}f$, accentuating the nonlinearity of the problem, is carried by the operator $Q_{\mathbf{m}}f(z) = \widehat{Q}_{\mathbf{m}}f(z) - 2 \sum_{n \geq 1} m_n n^2 z^2$. Thus, if f is convex, this mapping, to which we refer as the \mathbf{m} -transform of f , is the identity; actually, the same remains true even if f is $2m_1$ -convex, in the sense that the function $z \mapsto f(z) + 2m_1 z^2$ is convex. If, however, the function f is not $2m_1$ -convex, the \mathbf{m} -transform of f is nontrivial. Thus, the function $Q_{\mathbf{m}}f(z)$ is in general non-convex and $Q_{\mathbf{m}}f(z) > f^{**}(z)$ for some z ; the non-convexity of $Q_{\mathbf{m}}f(z)$ depends sensitively and ‘nonlocally’ on the penalizing sequence \mathbf{m} .

Indeed, recall that $\widehat{Q}_{\mathbf{m}}f$ can be viewed as an *operator* acting on the non-convex function f and producing an \mathbf{m} -dependent function which effectively represents a constrained relaxation of f . In the same vein, the function $Q_{\mathbf{m}}f$ represents a nonlocally *constrained convexification* of f . Interpreted in such a way, the construction of $Q_{\mathbf{m}}f$ is reminiscent of energy quasi-convexification in continuum elasticity. The latter deals with minimization of the functionals $\int f(\mathbf{F})d\mathbf{x}$, where \mathbf{F} is a matrix field. The role of nonlocal constraint in such problems is played by the condition $\text{curl } \mathbf{F} = 0$, which is highly nontrivial in a multidimensional setting [71]. In a one-dimensional setting this whole construction can be imitated through the introduction

of a penalizing kernel \mathbf{m} mimicking the Green's function of the constraint. As in the case of continuum elasticity, such a penalization can introduce incompatibility, which in a discrete setting can lead to geometrical frustration.

One of the goals of this paper will be to link the degree of the non-convexity of the function $Q_{\mathbf{m}}f$ with the breakdown of the GCB rule. For instance, in the parametric domain where periodic microstructures are optimal, one can also expect the convexity of the function $Q_{\mathbf{m}}f$ (see Remark 3.28 and the example analyzed in Section 4). Topologically different periodic microstructures will exist in finite intervals of z where they can be 'stretched' to secure the commensurability with the lattice (see for instance Theorem 4.1 and for a detailed analysis the examples in Sections 4.2.3). In such intervals the corresponding minimizers possess 'global' properties and the GCB rule is respected. However, in general, when z is varied continuously, the optimal microstructure will change discontinuously and the domain of applicability of the GCB rule can *coexist* with the domains where it breaks down (see for instance the example in Section 5.3.1 and the analysis in Sections 5.4.1 and 5.4.2). The challenge is to identify the conditions on \mathbf{m} , when, for instance, the knowledge of the intervals where GCB rule is applicable, allows one to re-construct the \mathbf{m} -transform of a given non-convex function f also for z where the GCB rule is non-applicable.

In this paper we are not attempting to solve the problem posed above in its full generality and instead focus on a physically interesting sub-class of non-convex functions f allowing one to construct *explicit* solutions of the minimization problem for several important classes of penalizing kernels \mathbf{m} .

Specifically, we aim at the development of a comprehensive theory for *bi-convex* functions f . More precisely, we assume that there is a value $z = z^*$ such that the restrictions of f to $(-\infty, z^*]$ and $[z^*, +\infty)$ are both convex; well-known examples of bi-convex functions are the quadratic double-well potential ($f(z) = (|z| - 1)^2$ with $z^* = 0$), used for the description of phase transitions, and the truncated quadratic potential ($f(z) = z^2$ if $z \leq 1$ and $f(z) = 1$ if $z \geq 1$, with $z^* = 1$), which is used in Fracture Mechanics. In what follows we often refer to the two convex branches of f as *microscopic phases*.

An important property of the bi-convex functions f is that, independently of the choice of the kernels \mathbf{m} , the mapping $\widehat{Q}_{\mathbf{m}}f$ is largely characterized by a phase function $\theta = \theta(z)$ which represents the asymptotic volume fraction of one of the 'phases' in the limiting minimizer, say the limit of the percentage of indices i for which $u_i^k - u_{i-1}^k \geq z^*$. When f is convex, then $\theta = 0$ or $\theta = 1$ and when it is bi-convex, the central question will be to describe for a given \mathbf{m} the form of $\theta(z)$. As we show, the applicability of GCB can be related to the emergence of the \mathbf{m} -dependent 'steps' on the graph of the function θ represented by the values $\bar{\theta}$ for which $\{z : \theta(z) = \bar{\theta}\}$ is a non-degenerate interval. In what follows we refer to such intervals as *locking* states and to the corresponding GCB-type microstructures as *mesoscopic phases*. This characterization is justified by the fact that in the locking states the form of minimizers is *stable* in the sense that the set of indices i at finite k such that that $u_i^k - u_{i-1}^k \geq z^*$ is independent of z , up to an asymptotically negligible fraction. Therefore, the implied 'staircase' structure of the function θ is not a feature of the discrete problem only as it survives in the continuum

limit. As we show, the locking states have the desired global properties, and for such states an appropriate finite ‘cell’ problem can be formulated and solved. In other words, in such states the GCB rule is operative and the computation of the macroscopic energy energy can be made explicit. In this paper we have chosen to illustrate all these effects by considering penalization kernels \mathbf{m} amenable to fully *explicit* study. Our analysis shows that a rather comprehensive picture can be obtained based on the analysis of just two archetypal *classes* of kernels.

The first class of analytically transparent kernels contains ‘concentrated’ (compact, localized, narrow banded, etc.) parametric sequences \mathbf{m} defined by the condition that there exists $M \geq 2$ such that $m_n = 0$ if $n \geq 2$ and $n \neq M$; here M plays the role of a parameter. We prove that for such kernels (and independently of f , as long as it is non-convex) locking states do exist and correspond to $\theta_n = \frac{n}{M}$ with $n \in \{0, \dots, M\}$. Minimizers in this case, representing mesoscopic phases, are M -periodic. Moreover, we prove that the associated phase function θ is piecewise affine, interpolating locally between the locking states θ_{n-1} and θ_n . Thus, while for θ that is not a locking state we do not have GCB-type minimizers (with ‘global’ properties), the whole mapping $\widehat{Q}_{\mathbf{m}}f$ can be recovered from the knowledge of its value at those z corresponding to locking states where the GCB rule is operative.

The second class of analytically transparent kernels contains exponentially decaying sequences \mathbf{m} which we write in the parametric form $m_n = e^{-\sigma n}$ with $\sigma > 0$ playing the role of a parameter analogous to M in the first class. Here again we can give a complete description of the relaxed problem, for instance, when f is a truncated convex potential (f is constant in $[z^*, +\infty)$). Given this particular structure of non-convex potentials (describing, for instance, lattice fracture), locking states are either $\theta = 0$ or $\theta \in \{\frac{1}{k} : k \in \mathbb{N}\}$. In the latter case, minimizers are k -periodic and therefore of GCB-type, which means that they possess ‘global’ properties. Interestingly, we show that in each period such minimizers have a single difference $u_i^k - u_{i-1}^k$ exceeding the threshold z^* (single ‘crack’). Again, we prove that the set of mesoscopic phases is sufficiently rich to provide the ‘building blocks’ whose simple mixtures allow one to construct the whole mapping $\widehat{Q}_{\mathbf{m}}f$. An important difference with the case of ‘concentrated’ kernels is that now the optimal ‘simple’ mixtures of ‘global’ (or GCB) states are not unique optimal microstructures. More precisely, we show that even for *non-locking* values of z one can build optimal minimizers which are of GCB-type. For all values of z such minimizers are *quasiperiodic* and therefore possess the desired ‘global’ properties, thus broadening the spectrum of possible GCB-type microstructures.

All these explicit results, which also include an analytical study of the intricate role of the parameters σ and M , can be obtained because for these two classes of kernels (concentrated and exponential) one can reformulate the original non-additive (non-local) minimum problem with presumably complex mixing properties as an additive (local) problem with no mixing effects at all. For concentrated kernels this is achieved by rewriting the non-additive problem as a superposition of additive problems. For exponential kernels the reduction of complexity is due to the mapping of a scalar problem with long-range interactions on a vectorial problem with only nearest-neighbor interactions.

Variational problems with energies like (1.4) have been studied extensively in physical literature where they emerged independently in different settings ranging from conventional magnetic and mechanical systems [10, 67] to discotic liquid crystals [42, 57, 64]. In such problems the optimal periodicity of a microstructure representing the ground state (global minimum of the energy) competes with the periodicity of the lattice, and the geometrical frustration emerges when the two periodicities are incompatible (for instance, incommensurate). Since the interactions in actual physical systems are very complex, the main focus was on the study of simplified discrete models such as the Frenkel-Kontorova model [35] or the classical ANNNI model [94]. A prototypical Ising model with antiferromagnetic long-range interactions, which is the simplest problem of this same type was considered in [11]. Two explicit solutions for the class of problems with exponential kernels studied in the present paper, were found in [84, 85].

In the mathematical literature discrete and continuous variational models with antiferromagnetic interactions were considered in [28, 27, 86, 90, 39, 58]. An important link was established by S. Aubry and J. Mather between variational problems of type (1.4) and the quasiperiodic trajectories of discrete dynamical systems. Recent mathematical results extending Aubry-Mather theory can be found in [14, 59, 49, 54].

In the present paper we reformulate the problems studied previously in the framework of the theory of dynamical systems, as problems of the calculus of variations. This change of perspective allows one to apply powerful homogenization results providing direct access to the corresponding continuum limits. The goal is to demonstrate how, already in one-dimensional problems, the interplay between discreteness and non-convexity compromises the classical Cauchy-Born rule and precludes the use of conventional ‘cell’ problems for computation of the relaxed energies.

In the context of discrete-to-continuum transitions, the obtained results bring new understanding of the role of the frustrated non-local interactions in the determination of homogenized energies. While the case of ferromagnetic interactions has been extensively studied before, here we show that the introduction of anti-ferromagnetic interactions brings fundamentally new effects, most importantly the emergence of mesoscopic phases resulting in the locking of the minimizers on lattice-commensurate microstructures. These effects affect the structure of the continuum energy and do not disappear in the course of discrete-to-continuum transition.

Instead of the focus on Euler-Lagrange equations, characteristic of the theory of dynamical systems, our main tools are the direct methods of the calculus of variations. In particular, we obtained our main results through the use of the novel bounds resulting either from the judicious choice of periodic test functions or from cluster minimization. In this sense our results complement and broaden the findings made in the dynamical systems framework.

One result of this type is the characterization of the continuum limit when non-local interactions are concentrated on M -neighbors. The analysis of this case highlights the increasing difficulty of dealing with geometrical frustration and non-commensurability effects as progressively more distant interactions are incorporated, and suggests the possibility of scale-free

patterns even in the case of finite-range interaction kernels. It complements the results of Aubry [8], who showed that long-range interactions favor hyper-uniform solutions. Another result, allowing one to relate the regularity of the relaxed energies in θ with the existence of periodic solutions, can be viewed as an extension of the link between regularity and the rotation number established by Mather in the framework the dynamical systems approach [79].

In addition to explicit computations of global minimizers we also posed the problem of finding the Γ -equivalent continuum *approximations* of the corresponding lattice problems [34]; that is, the construction of asymptotic continuum theories accounting for the lattice scale in the spirit of [34]. We succeed in constructing such an approximation in the case of an exponential kernel while also showing that the conventional formal asymptotic limit, which neglects the underlying geometric frustration, underestimates the intricacies of the interplay between non-convexity, non-locality and discreteness and produces only a lower bound for $Q_{\mathbf{m}}f$. This explicit example serves as a cautionary tale demonstrating in which form the finite scale lattice effects can survive homogenization and affect the macroscopic variational problem.

2 Nonlocal discrete problems and their relaxation

In this paper we study the asymptotic behaviour of particular nonlocal discrete problems parameterized by the number of nodes involved. This can be viewed as a discrete-to-continuum homogenization process by introducing a small parameter ε and suitable scalings of the energies. However, with an abuse of terminology, we choose to label this process as the computation of a relaxed functional.

Following the usual terminology, a functional $\bar{\Phi}$ is the relaxation of an original functional Φ if, loosely speaking, infimum problems involving Φ have the same value as infimum problems involving $\bar{\Phi}$, and the latter admit solution (given that the corresponding problem is coercive), see e.g. [41, 21]. In the context of the Calculus of Variations, the relaxed functional is usually obtained by a lower-semicontinuous envelope with respect to some topology, it is stable under continuous perturbations, and often (but not always) is stable with respect to closed constraints, such as fixed boundary values or imposed integral constraints. Moreover, if the original functional depends on some energy density, often (but not always) the relaxed functional can be characterized by a new energy density obtained as a transformation (convexification, quasiconvexification, sub-additive or *BV*-elliptic envelope, etc.) of the original energy density, so that relaxation of an energy can be viewed as an operation on an energy density. In our case we deal with a sequence of minimum problems, so it would be correct to talk about homogenization or Γ -convergence rather than relaxation. Nevertheless, we would like to highlight properties of the homogenized continuum energy in the same spirit of a lower-semicontinuous envelope, and hence we choose the terminology of relaxation.

We focus on the relaxation of nonlocal discrete functionals of type (1.4). They involve a

non-convex function f and contain a ‘penalization kernel’ \mathbf{m} . The idea is to single out the local (nearest-neighbour) interaction in the general discrete-to-continuum problem, and consider the corresponding potential f as the function that needs to be ‘relaxed’. The nonlocal (beyond nearest-neighbour) interactions are assumed to be linear. The corresponding quadratic term in the energy brings the simplest penalization into the relaxation process. We show that even such a simple penalization may still carry incompatibility and may even lead to geometrical frustration. In what follows, with a slight abuse of terminology, we will be referring to (1.4) as a \mathbf{m} -dependent relaxation of a non-convex energy density f . Before giving the formal definitions, we make some preliminary comments distinguishing *penalized* relaxation from *non-penalized* relaxation.

2.1 Nearest-neighbour interaction and quadratic penalization

As it is well known, the convexification of a function f can be seen as the result of a discrete-to-continuum relaxation process in a local setting involving nearest-neighbour interactions only. To be more specific, for any $k \in \mathbb{N}$ and $z \in \mathbb{R}$ we introduce the set

$$\mathcal{A}(k; z) = \{u: [0, k] \cap \mathbb{N} \rightarrow \mathbb{R} \text{ such that } u(0) = 0, u(k) = kz\} \quad (2.1)$$

of admissible test functions satisfying boundary conditions. Here the parameter z represents the affine boundary conditions $u(i) = L_z(i)$, where $L_z(i) = iz$.

Proposition 2.1 (a characterization of the convex envelope). *Let $f: \mathbb{R} \rightarrow \mathbb{R}$. Then, the convex envelope of f is*

$$f^{**}(z) = \lim_{k \rightarrow +\infty} \frac{1}{k} \inf \left\{ \sum_{i=1}^k f(u(i) - u(i-1)) : u \in \mathcal{A}(k; z) \right\}.$$

It is useful in this context to interpret Proposition 2.1 as a consequence of discrete-to-continuum Γ -convergence (see e.g. [21, Ch. 4.2]). Indeed, define for a given bounded interval I and for any $\varepsilon > 0$ the set of indices $\mathcal{I}_\varepsilon(I)$ and the set of discrete functions $\mathcal{A}_\varepsilon(I)$ given by

$$\mathcal{I}_\varepsilon(I) = \{i \in \mathbb{Z} : \varepsilon i \in I\}, \quad \mathcal{A}_\varepsilon(I) = \{u: \mathcal{I}_\varepsilon(I) \rightarrow \mathbb{R}\}, \quad (2.2)$$

respectively. Here and in the sequel, u_i denotes the value $u(\varepsilon i)$, and we identify $u \in \mathcal{A}_\varepsilon(I)$ with its piecewise-constant extension in I . Having defined

$$F_\varepsilon^0(u; I) = \varepsilon \sum_{i, i-1 \in \mathcal{I}_\varepsilon(I)} f\left(\frac{u_i - u_{i-1}}{\varepsilon}\right) \quad (2.3)$$

for $u \in \mathcal{A}_\varepsilon(I)$, the Γ -limit with respect to the L^2 -convergence of F_ε^0 is the functional $F^0(u, I) = \int_I f^{**}(u') dt$ for $u \in H^1(I)$. Then, choosing $\varepsilon_k = \frac{1}{k}$, by the convergence of minimum problems

we get

$$\begin{aligned} f^{**}(z) &= \min\{F^0(u; (0, 1)) : u(0) = 0, u(1) = z\} \\ &= \lim_{k \rightarrow +\infty} \min\{F_{\varepsilon_k}^0(u; (0, 1)) : u(0) = 0, u(1) = z\}, \end{aligned}$$

which is the desired formula up to a change of variable.

Remark 2.2 (additivity). Note that the problems defining f^{**} are *additive*, in the sense that, setting

$$\mu(k, z) = \inf \left\{ \sum_{i=1}^k f(u_i - u_{i-1}) : u \in \mathcal{A}(k; z) \right\},$$

we have $\mu(k, z) = \min \{ \mu(k_1, z_1) + \mu(k_2, z_2) : k_1 + k_2 = k, k_1 z_1 + k_2 z_2 = kz \}$.

We now add to the nearest-neighbour term, described by a non-convex function f , a quadratic long-range term of the form

$$\sum_{i,j=0}^k m_{|i-j|} (u_i - u_j)^2,$$

which brings the simplest penalization of global inhomogeneity while promoting uniformity in the sense of averages. The sequence $\mathbf{m} = \{m_n\}_{n \in \mathbb{N}}$ is assumed to be such that

$$m_n \geq 0 \text{ for any } n \text{ and } m_n = o(n^{-\beta})_{n \rightarrow +\infty} \text{ for some } \beta > 3. \quad (2.4)$$

Such penalization has an ‘antiferromagnetic’ character, in that it in fact favors local oscillations induced by the non-convexity of f .

In the sequel, an important role will be played by the two special families of kernels: exponential, $m_n = e^{-\sigma n}$, and concentrated at some M , $m_n = 0$ for all n except $n = 1$ and $n = M$ with $M \geq 2$. In Fig. 1(A) we represent two exponential kernels for different σ . Also for concentrated kernels one can similarly account for a parameter σ by using the new definitions, $m_1^\sigma = (1/\sigma)m_1$ and $m_M^\sigma = (1/\sigma)m_M$, see Fig. 1(B).

Before formally defining the penalized energy, we need to make some assumptions on f . These assumptions will be used to obtain the existence of the limit of minimum problems. Note that the hypotheses can be relaxed, but they are stated as follows in order to avoid unnecessary technicalities. Our first simplifying assumption is that the (non-convex) potential $f: \mathbb{R} \rightarrow [0, +\infty)$ satisfy a quadratic growth hypothesis; namely,

$$0 \leq f(z) \leq c(z^2 + 1) \text{ for some } c > 0. \quad (2.5)$$

In addition to (2.5), we will also assume that the function f satisfies

$$\frac{1}{c} z^2 \leq f(z) + m_1 z^2. \quad (2.6)$$

Note that hypothesis (2.6) is automatically satisfied if $m_1 > 0$. We will point out specifically in which of the cases assumption (2.6) is not necessary.

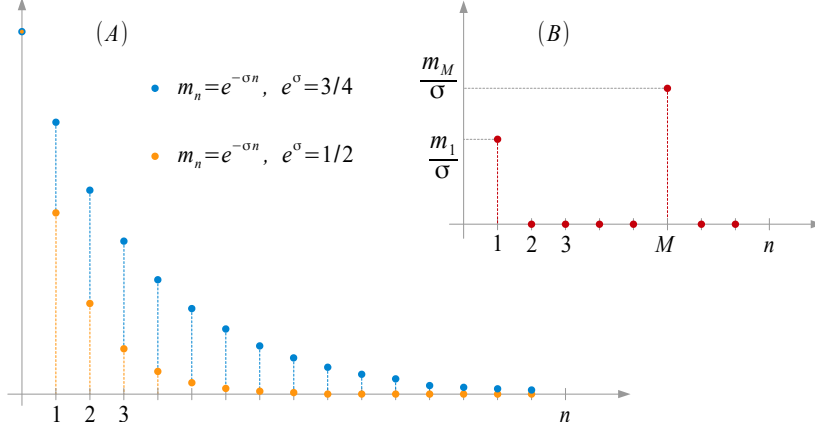

Figure 1: representation of exponential and concentrated kernels.

Definition 2.3 (relaxation with kernel \mathbf{m}). For all $z \in \mathbb{R}$ we set

$$\widehat{Q}_{\mathbf{m}}f(z) = \lim_{k \rightarrow +\infty} \frac{1}{k} \inf \left\{ \sum_{i=1}^k f(u_i - u_{i-1}) + \sum_{i,j=0}^k m_{|i-j|} (u_i - u_j)^2 : u \in \mathcal{A}(k; z) \right\}.$$

The function $\widehat{Q}_{\mathbf{m}}f$ is well defined since the limit exists by known discrete-to-continuum results (see formula (2.9) below). For this existence the growth condition is essential; however, in some cases we will use this formula also for some degenerate f for which the limit exists. Note that, except for the case when only nearest-neighbours are involved, the minimum problems defining $\widehat{Q}_{\mathbf{m}}f$ are not additive in the sense of Remark 2.2.

2.2 General properties of $\widehat{Q}_{\mathbf{m}}f(z)$

In this section, we list some properties of the relaxation with kernel \mathbf{m} derived from its variational nature.

Remark 2.4 (nearest-neighbour interactions). By Proposition 2.1, the convex envelope of f can be viewed as $\widehat{Q}_{\mathbf{0}}f$, where $\mathbf{m} = \mathbf{0}$ is the trivial kernel $m_n = 0$ for any $n \geq 1$; that is,

$$\widehat{Q}_{\mathbf{0}}f(z) = f^{**}(z). \quad (2.7)$$

More in general, again by Proposition 2.1, we obtain that $\widehat{Q}_{\mathbf{m}}f(z) = (f(z) + 2m_1 z^2)^{**}$ if $m_n = 0$ for any $n \geq 2$. Note that in these cases we have no non-additivity effects.

Remark 2.5 ($\widehat{Q}_{\mathbf{m}}f$ as a Γ -limit). The fact that $\widehat{Q}_{\mathbf{m}}f$ is well defined and some of its key properties follow by the fact that the functional F defined by $F(u) = \int_I \widehat{Q}_{\mathbf{m}}f(u') dt$ for I

bounded interval and $u \in H^1(I)$ can be interpreted as the Γ -limit of a suitable sequence of discrete functionals F_ε . Indeed, consider the functionals

$$F_\varepsilon(u; I) = \varepsilon \sum_{i, i-1 \in \mathcal{I}_\varepsilon(I)} f\left(\frac{u_i - u_{i-1}}{\varepsilon}\right) + \varepsilon \sum_{i, j \in \mathcal{I}_\varepsilon(I)} m_{|i-j|} \left(\frac{u_i - u_j}{\varepsilon}\right)^2 \quad (2.8)$$

defined in $\mathcal{A}_\varepsilon(I)$, with $\mathcal{I}_\varepsilon(I)$ and $\mathcal{A}_\varepsilon(I)$ as in (2.2). Such functionals can be rewritten as

$$F_\varepsilon(u; I) = \sum_{h \geq 1} \sum_{j, j+h \in \mathcal{I}_\varepsilon(I)} \varepsilon f^h\left(\frac{u_{j+h} - u_j}{\varepsilon h}\right)$$

where $f^1(z) = f(z) + 2m_1 z^2$ and $f^h(z) = 2z^2 h^2 m_h$ if $h > 1$. With this notation, functionals F_ε satisfy the hypotheses of [3, Theorem 6.3]; that is, $f^1(z) \geq c_1 z^2$ with $c_1 > 0$, and $f^h(z) \leq c_h z^2$ with $\sum_h c_h < +\infty$. The lower bound follows by the growth hypothesis (2.6), and the upper bound by (2.5) and by hypothesis (2.4) on \mathbf{m} . Hence, the Γ -limit of F_ε with respect to the L^2 -convergence is represented by the functional $F(u, I) = \int_I f_{\text{hom}}(u') dt$, where f_{hom} satisfies the homogenization formula

$$f_{\text{hom}}(z) = \lim_{k \rightarrow +\infty} \frac{1}{k} \inf \left\{ \sum_{h=1}^k \sum_{j=0}^{k-h-1} f^h\left(\frac{u_{j+h} - u_j}{h}\right) : u \in \mathcal{A}(k; z) \right\}. \quad (2.9)$$

Rewriting this formula, we get that the function f_{hom} coincides with the function $\widehat{Q}_{\mathbf{m}}f$ introduced in Definition 2.3, which proves that it is well-defined as a limit.

Remark 2.6. Note that, while condition (2.6) can be relaxed by requiring that f has a superlinear growth (not necessarily quadratic), it cannot be dropped altogether. Indeed, if $f = 0$, $m_2 \neq 0$ and $m_n = 0$ otherwise, then the limit in Definition 2.3 does not exist.

The following proposition states the convexity of $\widehat{Q}_{\mathbf{m}}f$, which is ensured by the lower semicontinuity of the Γ -limit.

Proposition 2.7 (convexity of $\widehat{Q}_{\mathbf{m}}f$). *Let \mathbf{m} be as in (2.4) and let $f: \mathbb{R} \rightarrow [0, +\infty)$ satisfy (2.5) and (2.6). Then the function $\widehat{Q}_{\mathbf{m}}f$ is convex.*

In the following remark we highlight that the boundary conditions can be transformed in conditions on a boundary layer, which are more convenient for computations.

Remark 2.8 (alternative statements of boundary conditions). The boundary conditions $u_0 = 0$ and $u_k = kz$ can be replaced by conditions on a boundary layer. We state two different equivalent possibilities, that will both be used in the proofs. In the first one the boundary

layer is a small portion of the whole domain, parameterized by a small δ , which then we let tend to 0, as follows

$$\begin{aligned}\widehat{Q}_{\mathbf{m}}f(z) &= \lim_{\delta \rightarrow 0} \liminf_{k \rightarrow +\infty} \frac{1}{k} \inf \left\{ \sum_{i=1}^k f(u_i - u_{i-1}) + \sum_{i,j=0}^k m_{|i-j|} (u_i - u_j)^2 : u \in \mathcal{A}_\delta(k; z) \right\} \\ &= \lim_{\delta \rightarrow 0} \limsup_{k \rightarrow +\infty} \frac{1}{k} \inf \left\{ \sum_{i=1}^k f(u_i - u_{i-1}) + \sum_{i,j=0}^k m_{|i-j|} (u_i - u_j)^2 : u \in \mathcal{A}_\delta(k; z) \right\},\end{aligned}\quad (2.10)$$

where

$$\mathcal{A}_\delta(k; z) = \{u \in \mathcal{A}(k; z) : u_i = iz \text{ if } i \leq \delta k \text{ and } i \geq (1 - \delta)k\}.$$

In the second one the double limit is replaced by a k -depending boundary layer at a mesoscopic scale, as follows

$$\widehat{Q}_{\mathbf{m}}f(z) = \lim_{k \rightarrow +\infty} \frac{1}{k} \inf \left\{ \sum_{i=1}^k f(u_i - u_{i-1}) + \sum_{i,j=0}^k m_{|i-j|} (u_i - u_j)^2 : u \in \mathcal{A}_{k^\alpha}(k; z) \right\}, \quad (2.11)$$

with $\alpha \in (-1, 0)$.

These formulas can be proved by an argument which is customary to variational treatments of homogenization problems (see e.g. [3]). In proving formulas (2.10) and (2.11), it is necessary to use the growth hypothesis (2.6). In case it does not hold, the limits in formulas (2.10) and (2.11) may be different from the limit in the definition of $\widehat{Q}_{\mathbf{m}}f$.

We now give some general estimates on $\widehat{Q}_{\mathbf{m}}f$.

Remark 2.9 (estimates by decomposition for $\widehat{Q}_{\mathbf{m}}f$). If $\mathbf{m} = \mathbf{m}' + \mathbf{m}''$; that is, $m_n = m'_n + m''_n$ for all n , and $f = g + h$, then we have

$$\widehat{Q}_{\mathbf{m}}f(z) \geq \widehat{Q}_{\mathbf{m}'}g(z) + \widehat{Q}_{\mathbf{m}''}h(z).$$

In Remark 2.4 we have examined the case when $\mathbf{m} = \mathbf{0}$. It may be of interest to consider the case when conversely $f = 0$ as in the following lemma. If \mathbf{m} is as in (2.4), then we set

$$a_{\mathbf{m}} = 2 \sum_{n=1}^{+\infty} m_n n^2. \quad (2.12)$$

Lemma 2.10 (minimization of the quadratic part). *Let $m_1 > 0$, so that (2.6) is satisfied with $f = 0$. Then we have $\widehat{Q}_{\mathbf{m}}0(z) = a_{\mathbf{m}}z^2$.*

Proof. By using $u_i = iz$ as a test function in the definition of $\widehat{Q}_{\mathbf{m}0}(z)$ we get the inequality $\widehat{Q}_{\mathbf{m}0}(z) \leq a_{\mathbf{m}}z^2$, after noting that

$$\lim_{k \rightarrow +\infty} \frac{1}{k} \sum_{i,j=0}^k m_{|i-j|} (i-j)^2 = \lim_{k \rightarrow +\infty} \frac{2}{k} \sum_{n=1}^k (k-n+1) m_n n^2 = 2 \sum_{n=1}^{+\infty} m_n n^2 = a_{\mathbf{m}}.$$

It then suffices to prove that for all fixed N we have

$$\widehat{Q}_{\mathbf{m}0}(z) \geq 2 \sum_{n=1}^N m_n n^2 z^2.$$

With fixed $\alpha \in (-1, 0)$, let u be a test function for the problem in (2.11) with $f = 0$ for $k^{1+\alpha} > N$. We then have

$$\frac{1}{k} \left(\sum_{i=1}^k 2m_1 (u_i - u_{i-1})^2 \right) \geq 2m_1 z^2. \quad (2.13)$$

If $n \in \{2, \dots, N\}$ and $\ell \in \{0, \dots, n-1\}$, let $i_\ell = \lceil \frac{k-\ell}{n} \rceil$. We can rewrite the energy due to interactions at distance n as

$$\begin{aligned} \frac{1}{k} 2m_n \sum_{\ell=0}^{n-1} \sum_{i=1}^{i_\ell} (u_{\ell+in} - u_{\ell+(i-1)n})^2 &\geq \frac{1}{k} 2m_n \sum_{\ell=0}^{n-1} i_\ell \left(\frac{1}{i_\ell} \sum_{i=1}^{i_\ell} (u_{\ell+in} - u_{\ell+(i-1)n}) \right)^2 \\ &= \frac{1}{k} 2m_n \sum_{\ell=0}^{n-1} i_\ell \left(\frac{u_{\ell+i_\ell n} - u_\ell}{i_\ell} \right)^2 = \frac{1}{k} 2m_n \sum_{\ell=0}^{n-1} i_\ell n^2 z^2 \\ &\geq 2m_n \frac{n}{k} \left\lceil \frac{k-n}{n} \right\rceil n^2 z^2 = 2m_n (1 + o_k(1)) n^2 z^2, \end{aligned}$$

where we have used the convexity inequality and the boundary condition $u_j = jz$ close to the boundary. Summing up for $n \in \{2, \dots, N\}$ and using (2.13), we prove the claim. \square

In the following proposition we compare $\widehat{Q}_{\mathbf{m}}f$ with the convex envelope of f and with f itself (to be more accurate, taking into account the case that f is not lower semicontinuous, with the lower-semicontinuous envelope of f).

Proposition 2.11 (trivial bounds for $\widehat{Q}_{\mathbf{m}}f$). *Let \mathbf{m} be as in (2.4) and let $f: \mathbb{R} \rightarrow [0, +\infty)$ satisfy (2.5) and (2.6). The inequalities*

$$f^{**}(z) + a_{\mathbf{m}}z^2 \leq \widehat{Q}_{\mathbf{m}}f(z) \leq (f(z) + a_{\mathbf{m}}z^2)^{**} \leq \bar{f}(z) + a_{\mathbf{m}}z^2 \quad (2.14)$$

hold, where \bar{f} denotes the lower-semicontinuous envelope of f ; i.e., the largest lower-semicontinuous function not larger than f .

Proof. By using $u_i = iz$ as a test function in the definition of $\widehat{Q}_{\mathbf{m}}f(z)$ we get the inequality $\widehat{Q}_{\mathbf{m}}f(z) \leq f(z) + a_{\mathbf{m}}z^2$ as in the first part of the proof of Lemma 2.10. Since $\widehat{Q}_{\mathbf{m}}f$ is continuous by Proposition 2.7, this ensures that $\widehat{Q}_{\mathbf{m}}f(z) \leq \bar{f}(z) + a_{\mathbf{m}}z^2$. Since $\widehat{Q}_{\mathbf{m}}f(z)$ is convex, we also obtain $\widehat{Q}_{\mathbf{m}}f(z) \leq (f(z) + a_{\mathbf{m}}z^2)^{**}$. The lower bound is obtained by using Remark 2.9 with the choice $g = f$, $h = 0$, $\mathbf{m}' = \mathbf{0}$ and $\mathbf{m}'' = \mathbf{m}$. This gives

$$\widehat{Q}_{\mathbf{m}}f(z) \geq \widehat{Q}_{\mathbf{0}}f(z) + \widehat{Q}_{\mathbf{m}}0(z) = f^{**}(z) + a_{\mathbf{m}}z^2$$

since $\widehat{Q}_{\mathbf{m}}0(z) = a_{\mathbf{m}}z^2$ by Lemma 2.10, and $\widehat{Q}_{\mathbf{0}}f(z) = f^{**}(z)$. \square

Corollary 2.12. *If f is convex, then $\widehat{Q}_{\mathbf{m}}f(z) = f(z) + a_{\mathbf{m}}z^2$.*

Remark 2.13 (non-sharpness of lower bounds by decomposition). If we apply Corollary 2.12 to the estimate in Remark 2.9 with h convex and $\mathbf{m}'' \neq \mathbf{0}$, then the estimate gives an equality only if $\widehat{Q}_{\mathbf{m}}f(z) = f(z) + a_{\mathbf{m}}z^2$.

2.3 Lower bound: optimization on nearest-neighbour clusters

Rather remarkably, one can explicitly compute $\widehat{Q}_{\mathbf{m}}f$ when there is only one non-zero coefficient m_M of \mathbf{m} beside nearest neighbours. The computation is obtained by optimizing on clusters of nearest neighbours of length M . As a consequence one can obtain lower bound for a general \mathbf{m} , which are in general not sharp but however useful.

For any given $\lambda \geq 0$, we set

$$f_{\lambda}(z) = f(z) + \lambda z^2. \tag{2.15}$$

In particular $f_{2m_1}(z) = f(z) + 2m_1z^2$ describes the total energy due to nearest-neighbour interactions. We first rewrite Corollary 2.12 in terms of the effect of the convexity of this contribution.

Proposition 2.14 (convex nearest-neighbour interactions). *Let f be such that f_{2m_1} is convex. Then*

$$\widehat{Q}_{\mathbf{m}}f(z) = f(z) + a_{\mathbf{m}}z^2.$$

*More in general, for an arbitrary f this equality holds at all z such that $f_{2m_1}(z) = f_{2m_1}^{**}(z)$.*

Proof. Applying Remark 2.9 with $g = f$, $h = 0$ and \mathbf{m}' defined as $m'_1 = m_1$ and $m'_n = 0$ if $n \geq 2$, for all z such that $f_{2m_1}(z) = f_{2m_1}^{**}(z)$ we have

$$\widehat{Q}_{\mathbf{m}}f(z) \geq \widehat{Q}_{\mathbf{m}'}f(z) + \widehat{Q}_{\mathbf{m}''}0(z) = f_{2m_1}^{**}(z) + a_{\mathbf{m}''}z^2 = f_{2m_1}(z) + a_{\mathbf{m}''}z^2 = f(z) + a_{\mathbf{m}}z^2,$$

where we have used Remark 2.4, Lemma 2.10 and the convexity hypothesis. The converse inequality holds by Proposition 2.11. \square

Now, we can define nearest-neighbour cluster energies. More precisely, for any integer $M \geq 2$ we define

$$P^M f(z) = \frac{1}{M} \min \left\{ \sum_{j=1}^M f_{2m_1}(z_j) : \sum_{j=1}^M z_j = Mz \right\} + 2m_M M^2 z^2. \quad (2.16)$$

For completeness of notation, we also set $P^1 f(z) = f_{2m_1}(z)$.

Note that if $M \geq 2$ and f_{2m_1} is convex then $P^M f(z) = f(z) + 2m_1 z^2 + 2m_M M^2 z^2$.

Definition 2.15 (concentrated kernels). *Let $M \geq 1$. We say that a kernel \mathbf{m} is concentrated at M if $m_n = 0$ if $n \notin \{1, M\}$.*

Proposition 2.16 (relaxation with concentrated kernel). *If \mathbf{m} is concentrated at M , then $\widehat{Q}_{\mathbf{m}} f = (P^M f)^{**}$.*

Proof. Remark 2.4 proves the claim for $M = 1$. Now, assume $M \geq 2$. We can use formula (2.11) for the computation of $\widehat{Q}_{\mathbf{m}} f(z)$; in particular, we may suppose that test functions satisfy $u_i = zi$ if $i \leq M$ and $i \geq k - M$. Let u be a minimizer; using the notation in the proof of Lemma 2.10 with $i_\ell = \lceil \frac{k-\ell}{M} \rceil$, we can write,

$$\begin{aligned} & \sum_{i=1}^k \left(f(u_i - u_{i-1}) + 2m_1(u_i - u_{i-1})^2 \right) + 2m_M \sum_{i=M}^k (u_i - u_{i-M})^2 \\ = & \sum_{\ell=0}^{M-1} \sum_{i=1}^{Mi_\ell} \frac{1}{M} \left(f(u_i - u_{i-1}) + 2m_1(u_i - u_{i-1})^2 \right) + 2m_M \sum_{\ell=0}^{M-1} \sum_{i=1}^{i_\ell} (u_{\ell+iM} - u_{\ell+(i-1)M})^2 + C_z, \end{aligned}$$

where C_z is a constant taking into account extra boundary interactions, with $|C_z| \leq MC(1 + z^2)$ independent of k . We then estimate

$$\begin{aligned} & \sum_{\ell=0}^{M-1} \sum_{i=1}^{Mi_\ell} \frac{1}{M} \left(f(u_i - u_{i-1}) + 2m_1(u_i - u_{i-1})^2 \right) + 2m_M \sum_{\ell=0}^{M-1} \sum_{i=1}^{i_\ell} (u_{\ell+iM} - u_{\ell+(i-1)M})^2 \\ & \geq \sum_{\ell=0}^{M-1} \sum_{i=1}^{i_\ell} P^M f \left(\frac{u_{\ell+iM} - u_{\ell+(i-1)M}}{M} \right) \geq \sum_{\ell=0}^{M-1} \sum_{i=1}^{i_\ell} (P^M f)^{**} \left(\frac{u_{\ell+iM} - u_{\ell+(i-1)M}}{M} \right) \\ & \geq \sum_{\ell=0}^{M-1} i_\ell (P^M f)^{**} \left(\frac{u_{\ell+i_\ell M} - u_\ell}{i_\ell M} \right) = \sum_{\ell=0}^{M-1} i_\ell (P^M f)^{**}(z) \\ & \geq M \left\lceil \frac{k-M}{M} \right\rceil (P^M f)^{**}(z). \end{aligned}$$

Dividing by k and taking the limit as $k \rightarrow +\infty$ we obtain the lower bound.

To prove that the lower bound is sharp it suffices to choose a minimizer z_1, \dots, z_M for $P^M f(z)$, extend it by M -periodicity and define a test function u on $\{0, \dots, k\}$ with $k = nM$ by setting $u_0 = 0$, $u_i - u_{i-1} = z$ if $i \in \{1, \dots, M\} \cup \{k - M + 1, \dots, k\}$, and $u_i - u_{i-1} = z_i$ otherwise. Using this test function and letting $k \rightarrow +\infty$, we obtain $\widehat{Q}_{\mathbf{m}} f \leq P^M f$. Since $\widehat{Q}_{\mathbf{m}} f$ is convex, we finally get $\widehat{Q}_{\mathbf{m}} f \leq (P^M f)^{**}$. \square

Remark 2.17 (general concentrated interactions). In the previous proposition we have considered quadratic interactions between M th neighbours. Actually, it is not necessary to assume quadraticity or even convexity of these interactions, and the same proof shows that

$$\lim_{k \rightarrow +\infty} \frac{1}{k} \min \left\{ \sum_{i=1}^k f(u_i - u_{i-1}) + \sum_{i=M}^k g(u_i - u_{i-M}) : u_0 = 0, u_k = kz \right\} = \psi^{**}(z), \quad (2.17)$$

where $f, g: \mathbf{R} \rightarrow [0, +\infty)$ are such that f is of quadratic growth and g satisfies a quadratic bound from above, and ψ is defined by

$$\psi(z) = \frac{1}{M} \min \left\{ \sum_{j=1}^M f(z_j) : \sum_{j=1}^M z_j = Mz \right\} + g(z). \quad (2.18)$$

Remark 2.18 (periodic recovery sequences and multiplicity of minimizers). Note that if $P^M f(z) = (P^M f)^{**}(z)$ and $\{z_i\}$ is a minimizer for $P^M f(z)$ extended by M -periodicity, a function u with $u_0 = 0$, $u_i - u_{i-1} = z_i$ gives a recovery sequence for the Γ -limit of the functionals (2.8) at $u(x) = zx$. Note that $u_i - zi$ is M -periodic.

We also observe that if $\{z_1, \dots, z_M\}$ is a minimizer, then any permutation of its values gives a minimizer.

Proposition 2.19 (a lower bound for general \mathbf{m}). *Let \mathbf{m} be any kernel; then for any M the following estimate holds*

$$\widehat{Q}_{\mathbf{m}} f(z) \geq (P^M f)^{**}(z) + 2 \sum_{\substack{n \geq 2 \\ n \neq M}} n^2 m_n z^2, \quad (2.19)$$

and in particular we have $\widehat{Q}_{\mathbf{m}} f(z) \geq \sup_{M \geq 1} \left((P^M f)^{**}(z) + 2 \sum_{\substack{n \geq 2 \\ n \neq M}} n^2 m_n z^2 \right)$.

Proof. Inequality (2.19) is obtained by using Remark 2.9 with $\mathbf{m}' = (m_1, 0, \dots, 0, m_M, 0, \dots)$, Proposition 2.16, and the fact that $\widehat{Q}_{\mathbf{m}'} 0(z) = 2 \sum_{n \notin \{1, M\}} n^2 m_n z^2$. If $M = 1$, the estimate is an immediate consequence of Remarks 2.4 and 2.9. \square

2.4 Upper bound: optimization over periodic patterns

In order to give an upper bound for $\widehat{Q}_{\mathbf{m}}f$, it is of interest to consider minimum problems on sets of N -periodic functions. We will see that when the value $\widehat{Q}_{\mathbf{m}}f(z)$ is obtained by this periodic minimization, which can be interpreted as a Cauchy-Born approach, it is possible to deduce further structural properties of the relaxed functional.

For $N \in \mathbb{N}$ we define

$$\widehat{R}_{\mathbf{m}}^N f(z) = \frac{1}{N} \inf \{ F^\#(u; [0, N]) : i \mapsto u_i - zi \text{ is } N\text{-periodic} \}, \quad (2.20)$$

where

$$F^\#(u; [0, N]) = \sum_{i=1}^N f(u_i - u_{i-1}) + \sum_{i=1}^N \sum_{j \in \mathbb{Z}} m_{|i-j|} (u_i - u_j)^2.$$

Note that each site $i \in \{1, \dots, N\}$ interacts with all $j \in \mathbb{Z}$. Using periodic functions as test functions in the Γ -limit producing $\widehat{Q}_{\mathbf{m}}f$ (see Remark 2.5), we see that $\widehat{R}_{\mathbf{m}}^N f(z) \geq \widehat{Q}_{\mathbf{m}}f(z)$ for all N , so that, setting

$$\widehat{R}_{\mathbf{m}} f(z) = \left(\inf_N \widehat{R}_{\mathbf{m}}^N f(z) \right)^{**},$$

we obtain a bound for the \mathbf{m} -relaxation of f . More specifically, we can write

$$f(z) + a_{\mathbf{m}} z^2 \geq \widehat{R}_{\mathbf{m}}^N f(z) \geq \widehat{R}_{\mathbf{m}} f(z) \geq \widehat{Q}_{\mathbf{m}}f(z) \geq a_{\mathbf{m}} z^2 \quad (2.21)$$

where N is arbitrary; the first estimate is obtained by taking $u_i = iz$.

An application of Remark 2.8 to boundary conditions allows one to show that in (2.20) we can asymptotically neglect the interaction terms with sites outside $[0, N]$. Then, we have the following proposition.

Proposition 2.20. *For all $z \in \mathbb{R}$ we have $\widehat{R}_{\mathbf{m}} f(z) = \lim_{N \rightarrow +\infty} \widehat{R}_{\mathbf{m}}^N f(z) = \widehat{Q}_{\mathbf{m}}f(z)$.*

Accordingly, the \mathbf{m} -relaxation can be alternatively defined as a limit of minimum problems constructed on periodic functions.

Remark 2.21 (global periodic solutions). Note that in general the equality in Proposition 2.20 is not attained at finite N . However, in some cases the knowledge of $\widehat{R}_{\mathbf{m}}^N f$ for some finite N is sufficient for the description of $\widehat{Q}_{\mathbf{m}}f$. A notable case is that of nearest and next-to-nearest neighbor interactions, for which a general formula for $\widehat{Q}_{\mathbf{m}}f$ can be proven using this approach. In the notation above that formula simply reads $\widehat{Q}_{\mathbf{m}}f = (\widehat{R}_{\mathbf{m}}^2 f)^{**}$ [29, 86]. In particular, if f is a double-well energy with minimum value 0 attained for $z \in \{-1, 1\}$ then in a neighbourhood of 0 we have $\widehat{Q}_{\mathbf{m}}f(z) = \widehat{R}_{\mathbf{m}}^2 f(z)$; that is, the minimum for $\widehat{Q}_{\mathbf{m}}f(z)$ is reached on functions with $u_i - zi$ 2-periodic, up to an error due to the boundary conditions and vanishing as $k \rightarrow +\infty$. In this sense, such problems have ‘global’ solutions and are therefore solvable by the application of the GCB rule.

2.5 The \mathbf{m} -transform of f

In view of Proposition 2.11, in order to compare $\widehat{Q}_{\mathbf{m}}f$ with f we can subtract the quadratic term. In this way, the bounds in (2.14) are rewritten as

$$f^{**}(z) \leq \widehat{Q}_{\mathbf{m}}f(z) - a_{\mathbf{m}}z^2 \leq \bar{f}(z). \quad (2.22)$$

This suggests to interpret the function $\widehat{Q}_{\mathbf{m}}f(z) - a_{\mathbf{m}}z^2$ as an independent operator acting on f . We then give the following definition.

Definition 2.22 (\mathbf{m} -transform of f). *Let \mathbf{m} be as in (2.4) and let $f: \mathbb{R} \rightarrow [0, +\infty)$ satisfy (2.5) and (2.6). The \mathbf{m} -transform of f is the function $Q_{\mathbf{m}}f: \mathbb{R} \rightarrow [0, +\infty)$ defined as*

$$Q_{\mathbf{m}}f(z) = \widehat{Q}_{\mathbf{m}}f(z) - a_{\mathbf{m}}z^2. \quad (2.23)$$

Given that, by (2.22),

$$f^{**}(z) \leq Q_{\mathbf{m}}f(z) \leq \bar{f}(z), \quad (2.24)$$

the \mathbf{m} -transform of f can be viewed as an \mathbf{m} -dependent interpolation between f and f^{**} .

We start the study of the \mathbf{m} -transform with the observation that at z fixed the construction of $Q_{\mathbf{m}}f(z)$ can be interpreted in a variational sense as a minimization problem with a penalization term involving a distance from the affine function L_z . This claim is justified by Remarks 2.23 and 2.24 below.

Remark 2.23 (variational definition of $Q_{\mathbf{m}}f$). Note that, when $u_i = iz$, then

$$a_{\mathbf{m}}z^2 = \lim_{k \rightarrow +\infty} \frac{1}{k} \sum_{i,j=0}^k m_{|i-j|} (i-j)^2 z^2 = \lim_{k \rightarrow +\infty} \frac{1}{k} \sum_{i,j=0}^k m_{|i-j|} (u_i - u_j)^2.$$

Hence, we have the equality

$$Q_{\mathbf{m}}f(z) = \lim_{k \rightarrow +\infty} \frac{1}{k} \inf \left\{ \sum_{i=1}^k f(u_i - u_{i-1}) + \sum_{i,j=0}^k m_{|i-j|} ((u_i - u_j)^2 - (i-j)^2 z^2) : u \in \mathcal{A}(k; z) \right\}. \quad (2.25)$$

Remark 2.24 (interpretation of the penalty term as a distance). If $m_1 > 0$, then the last sum in (2.25) is a measure of the distance from u_i to the affine function $L_z(i) = iz$. To show this, we first note that by Remark 2.8 we can restrict to test functions u such that $u_i = iz$ for $i \leq k^{\alpha+1}$ and $i \geq k - k^{\alpha+1}$ for some $\alpha \in (-1, 0)$.

Now, for any $\ell \in \{1, \dots, k\}$ we consider the sum of the terms with $|i-j| = \ell$, obtaining

$$\begin{aligned}
& \sum_{|i-j|=\ell} ((u_i - u_j)^2 - (i - j)^2 z^2) \\
&= \sum_{|i-j|=\ell} ((u_i - iz) - (u_j - jz))^2 + 2z \sum_{|i-j|=\ell} ((u_i - iz) - (u_j - jz))(i - j) \\
&= \sum_{|i-j|=\ell} ((u_i - iz) - (u_j - jz))^2 + 4z\ell \sum_{i-j=\ell} ((u_i - iz) - (u_j - jz)) \\
&= \sum_{|i-j|=\ell} ((u_i - iz) - (u_j - jz))^2 + 4z\ell \sum_{r=0}^{\ell-1} ((u_{k_{r,\ell}} - k_{r,\ell}z) - (u_r - rz)),
\end{aligned}$$

where $k_{r,\ell} = r + \ell \lfloor \frac{k-r}{\ell} \rfloor$.

If $\ell \leq k^{\alpha+1}$, then $r \leq k^\alpha k$ and $k_{r,\ell} = r + \ell \lfloor \frac{k-r}{\ell} \rfloor \geq k - \ell \geq (1 - k^\alpha)k$, so that $u_{k_{r,\ell}} - u_r = \ell \lfloor \frac{k-r}{\ell} \rfloor = \ell \lfloor \frac{k}{\ell} \rfloor$, and the last term in the sum vanishes, so that

$$\frac{1}{k} \sum_{|i-j| \leq k^{\alpha+1}} ((u_i - u_j)^2 - (i - j)^2 z^2) = \frac{1}{k} \sum_{|i-j| \leq k^{\alpha+1}} ((u_i - iz) - (u_j - jz))^2.$$

Now, we fix $\delta > 0$. Recalling the decay condition (2.4) on \mathbf{m} , there exists ℓ_δ such that for $\ell > \ell_\delta$ we have $m_\ell < \delta \ell^{-\beta}$. If k is such that $k^{\alpha+1} > \ell_\delta$, then

$$\begin{aligned}
& \frac{1}{k} \sum_{|i-j| > k^{\alpha+1}} m_{|i-j|} ((u_i - u_j)^2 - (i - j)^2 z^2) \leq \frac{2}{k} \sum_{\ell > k^{\alpha+1}} \sum_{i=\ell}^k m_\ell (u_i - u_{i-\ell})^2 \\
& \leq \frac{2}{k} \sum_{\ell > k^{\alpha+1}} \ell^2 m_\ell \sum_{i=1}^k (u_i - u_{i-1})^2 \leq \frac{2\delta}{k} \sum_{\ell > k^{\alpha+1}} \ell^{2-\beta} \sum_{i=1}^k (u_i - u_{i-1})^2.
\end{aligned}$$

Note that in our computations we limit to u satisfying $\sum_{i=1}^k (u_i - u_{i-1})^2 \leq Ck$ by (2.6), so that this term is negligible as $k \rightarrow +\infty$. Likewise, we obtain

$$\begin{aligned}
\frac{2m_1}{k} \sum_{i=1}^k (u_i - u_{i-1} - z)^2 & \leq \frac{1}{k} \sum_{\ell=1}^k \sum_{|i-j|=\ell} m_{|i-j|} ((u_i - u_j)^2 - (i - j)^2 z^2) \\
& \leq \frac{2}{k} \left(\sum_{\ell=1}^{\infty} \ell^2 m_\ell \right) \sum_{i=1}^k (u_i - u_{i-1} - z)^2.
\end{aligned}$$

This double inequality shows that the quadratic part is equivalent to the square of the L^2 norm of the derivative of $u - L_z$, where u is identified with the piecewise-affine function on $(0, 1)$ with $u' = u_i - u_{i-1}$ on $(\frac{i-1}{k}, \frac{i}{k})$.

We note that the remark above suggests the use of minimum problems as above in an implicit Euler scheme to obtain discrete orbits for a gradient-flow type evolution driven by the non-convex part of the energy, with the quadratic part acting as a dissipation. In view of Remark 2.5, the limit of such orbits as $\varepsilon \rightarrow 0$ and scaling accordingly the dissipation describes a continuum evolution in the spirit of minimizing movements as in [4]. However, the interplay of discreteness and scaling of the dissipation may influence the form of this evolution as shown in [33] (see also [5] for a prototypical example in dimension one, and [32] for a geometrical setting).

Some general algebraic properties deriving from the definition of $Q_{\mathbf{m}}f$ are the following.

Remark 2.25 (properties of $Q_{\mathbf{m}}$).

- (i) $Q_{\mathbf{m}}(f + g) \geq Q_{s\mathbf{m}}f + Q_{(1-s)\mathbf{m}}g$ for all $s \in (0, 1)$;
- (ii) if g is convex $Q_{\mathbf{m}}(f + g) \geq (Q_{\mathbf{m}}f) + g$;
- (iii) if g is affine then $Q_{\mathbf{m}}(f + g) = (Q_{\mathbf{m}}f) + g$;
- (iv) if $r \geq 0$, then $Q_{\mathbf{m}}(rf)(z) = rQ_{\mathbf{m}/r}f(z)$;
- (v) if $r \in \mathbb{R}$ and $(f \circ L_r)(z) = f(rz)$ then $Q_{\mathbf{m}}(f \circ L_r)(z) = Q_{\mathbf{m}/r^2}f(rz)$;
- (vi) if $\lambda \in \mathbb{R}$ and we denote $(f \circ T_\lambda)(z) = f(z - \lambda)$ then $Q_{\mathbf{m}}(f \circ T_\lambda)(z) = Q_{\mathbf{m}}f(z - \lambda)$.

Properties (i)-(v) follow directly from the definition of $Q_{\mathbf{m}}f$. We give some details for the proof of (vi), since for this we have to modify the boundary condition of the test functions, using (2.11) in Remark 2.8. For any test function u for $Q_{\mathbf{m}}(f \circ T_\lambda)(z)$ we consider u^λ given by $u_i^\lambda = u_i - \lambda i$, which is a test function for $Q_{\mathbf{m}}f(z - \lambda)$ obtaining

$$\begin{aligned} & \sum_{i=1}^k f(u_i - u_{i-1} - \lambda) + \sum_{i,j=0}^k m_{|i-j|}(u_i - u_j)^2 - \sum_{i,j=0}^k m_{|i-j|}(i-j)^2 z^2 \\ &= \sum_{i=1}^k f(u_i^\lambda - u_{i-1}^\lambda) + \sum_{i,j=0}^k m_{|i-j|}(u_i^\lambda - u_j^\lambda)^2 - \sum_{i,j=0}^k m_{|i-j|}(i-j)^2 (z - \lambda)^2 \\ & \quad + 2\lambda \sum_{i,j=0}^k m_{|i-j|}(u_i - u_j - z(i-j))(i-j). \end{aligned}$$

Then, (vi) holds if we show that

$$\lim_{k \rightarrow +\infty} \frac{1}{k} \sum_{i,j=0}^k m_{|i-j|}(u_i - u_j)(i-j) = a_{\mathbf{m}}z.$$

Now, we note that in the sum $\sum_{i,j=0}^k m_{|i-j|}(u_i - u_j)(i-j)$ we can regroup the terms with $|i-j| = \ell$ and obtain a telescopic sum whose ending terms are in the boundary layer. Hence,

since for each ℓ these sums are exactly ℓ , we have

$$\begin{aligned} \lim_{k \rightarrow +\infty} \frac{1}{k} \sum_{i,j=0}^k m_{|i-j|} (u_i - u_j)(i - j) &= \lim_{k \rightarrow +\infty} \frac{2}{k} \sum_{\ell=1}^k \ell (m_\ell (u_k - u_0) \ell) \\ &= \lim_{k \rightarrow +\infty} \frac{2}{k} k z \sum_{\ell=1}^k m_\ell \ell^2 = a_{\mathbf{m}} z, \end{aligned}$$

concluding the proof of (vi).

Definition 2.26 (stability under \mathbf{m} -transform). *We say that z is a point of \mathbf{m} -stability for f if $Q_{\mathbf{m}}f(z) = f(z)$. If this equality holds for all z , we say that f is \mathbf{m} -stable.*

Remark 2.27 (global properties of points of stability). Let z be a point of \mathbf{m} -stability for f . Then, the value of $\widehat{Q}_{\mathbf{m}}f(z)$ is realized by choosing the affine function $u \in \mathcal{A}(k; z)$ given by $u_i = iz$ in each minimum problem in Definition 2.3.

We recall that $f_\lambda(z) = f(z) + \lambda z^2$ as in (2.15).

Proposition 2.28 (\mathbf{m} -stability and convexity).

- (i) if f is \mathbf{m} -stable then $f_{a_{\mathbf{m}}}$ is convex;
- (ii) if f_{2m_1} is convex then f is \mathbf{m} -stable.

Proof. Claim (i) follows from the definition of \mathbf{m} -stability since $f_{a_{\mathbf{m}}} = \widehat{Q}_{\mathbf{m}}f$. Claim (ii) is given by Proposition 2.14. \square

Remark 2.29 ('moderately' non-convex functions are \mathbf{m} -stable). The proposition above implies that if f is 'moderately non-convex' then it is also \mathbf{m} -stable. This is valid in particular if f is twice differentiable and

$$\inf_z f''(z) > -4m_1. \quad (2.26)$$

Remark 2.30 (nearest-neighbour interactions). By Remark 2.4 we get that

- (i) if $m_n = 0$ for any $n \geq 1$, then $Q_{\mathbf{m}}f(z) = \widehat{Q}_{\mathbf{m}}f(z) = f^{**}(z)$;
- (ii) if $m_n = 0$ for any $n \geq 2$, then $Q_{\mathbf{m}}f(z) = (f(z) + 2m_1 z^2)^{**} - 2m_1 z^2$.

In the second case, we note that in general if $m_1 \neq 0$ both inequalities in (2.24) may be strict for some values of z . For example, if $f(z) = (1 - z^2)^2$ and $m_1 \leq 1$, then

$$Q_{\mathbf{m}}f(z) = \begin{cases} (1 - z^2)^2 & \text{if } z \leq -\sqrt{1 - m_1} \\ m_1(2 - m_1) - 2m_1 z^2 & \text{if } |z| \leq \sqrt{1 - m_1} \\ (1 - z^2)^2 & \text{if } z \geq \sqrt{1 - m_1}, \end{cases}$$

and both inequalities are strict for $|z| < \sqrt{1 - m_1}$ (see Fig. 2). Conversely, if $m_1 \geq 1$ then $Q_{\mathbf{m}}f(z) = f(z)$ for any z ; in particular in this case f is \mathbf{m} -stable (but not convex).

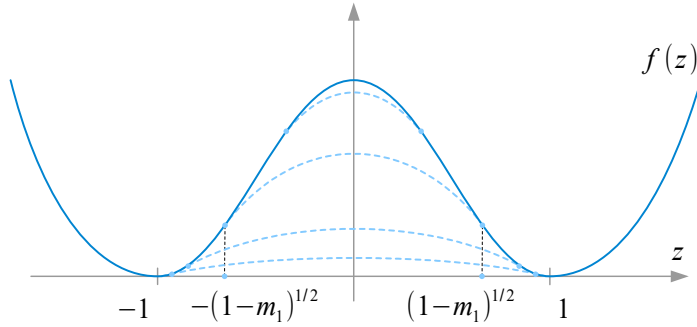

Figure 2: the function $Q_{\mathbf{m}}f$ in Remark 2.30 with $f(z) = (1 - z^2)^2$ for different values of $m_1 < 1$.

Remark 2.31 (regularity properties). From equality (2.23) we deduce that for any \mathbf{m} the operator $Q_{\mathbf{m}}$ has the same regularity properties of $\widehat{Q}_{\mathbf{m}}$; that is, $Q_{\mathbf{m}}f$ has the regularity properties of a convex function. In particular, $Q_{\mathbf{m}}f$ is locally Lipschitz, which is then a necessary condition for f to be \mathbf{m} -stable. Note that by (2.22) the convexity of f is a sufficient condition for the stability with respect to any \mathbf{m} .

Proposition 2.32. *Let $Q_{\mathbf{m}}^0 f = f$ and define iteratively $Q_{\mathbf{m}}^n f = Q_{\mathbf{m}}(Q_{\mathbf{m}}^{n-1} f)$. Then the sequence $Q_{\mathbf{m}}^n f$ is non-increasing and its limit $Q_{\mathbf{m}}^\infty f$ is \mathbf{m} -stable.*

Proof. The sequence is non-increasing by (2.22). Moreover $Q_{\mathbf{m}}^n f \geq f^{**}$ for all n . Since the functions $Q_{\mathbf{m}}^n f$ are equi-Lipschitz continuous by Remark 2.31, they converge uniformly on compact sets to their limit $Q_{\mathbf{m}}^\infty f$ by Ascoli-Arzelà's Theorem. Since $Q_{\mathbf{m}}$ is continuous with respect to the uniform convergence on compact sets, we have $Q_{\mathbf{m}}^\infty f = \lim_n Q_{\mathbf{m}}^n f = Q_{\mathbf{m}}(\lim_n Q_{\mathbf{m}}^{n-1} f) = Q_{\mathbf{m}}(Q_{\mathbf{m}}^\infty f)$. \square

The following proposition states that for non-trivial kernel concentrated at $M \geq 2$ stable functions are only f such that f_{2m_1} is convex, which is a trivial condition implying stability by Proposition 2.28(ii). Moreover, iteration of the \mathbf{m} transform gives a strictly decreasing sequence.

Proposition 2.33. *Let \mathbf{m} be a non-trivial kernel concentrated at $M \geq 2$; that is, with $m_M \neq 0$. In this case:*

- (i) f is \mathbf{m} -stable if and only if f_{2m_1} is convex;
- (ii) if f_{2m_1} is not convex then for any n , there exists z such that $Q_{\mathbf{m}}^n f(z) > Q_{\mathbf{m}}^{n+1} f(z)$;
- (iii) $Q_{\mathbf{m}}^\infty f(z) = f_{2m_1}^{**}(z) - 2m_1 z^2$.

Proof. (i) By Proposition 2.28 we only have to prove that the convexity of f_{2m_1} is necessary for the \mathbf{m} -stability of f . We then suppose that f is \mathbf{m} -stable and f_{2m_1} is not convex, and show that there exists \bar{z} such that $f(\bar{z}) > Q_{\mathbf{m}}f(\bar{z})$, contradicting the \mathbf{m} -stability of f .

From Proposition 2.14 we have that $\widehat{Q}_{\mathbf{m}}f(z) = f_{a_{\mathbf{m}}}(z)$ for all z such that $f_{2m_1}(z) = f_{2m_1}^{**}(z)$. We consider a maximal interval where $f_{2m_1} > f_{2m_1}^{**}$. By the growth conditions on f and its continuity (since we suppose that it is \mathbf{m} -stable) this interval is a bounded open interval (S_0, S_M) , and we have $\widehat{Q}_{\mathbf{m}}f(S_0) = f_{a_{\mathbf{m}}}(S_0)$ and $\widehat{Q}_{\mathbf{m}}f(S_M) = f_{a_{\mathbf{m}}}(S_M)$.

Note that, upon setting

$$r(z) = f_{2m_1}(S_0) + \frac{f_{2m_1}(S_M) - f_{2m_1}(S_0)}{S_M - S_0}(z - S_0),$$

for $z \in [S_0, S_M]$ we have

$$\frac{1}{M} \min \left\{ \sum_{j=1}^M f_{2m_1}(z_j) : \sum_{j=1}^M z_j = Mz \right\} \geq f_{2m_1}^{**}(z) = r(z),$$

with equality if and only if minimal z_j belong to $\{S_0, S_M\}$ for all j , which implies that $z \in \{S_h : h \in \{0, \dots, M\}\}$, where

$$S_h = S_0 + h \frac{S_M - S_0}{M}.$$

We then have

$$P^M f(S_h) = r(S_h) + 2m_M M^2 S_h^2.$$

Since

$$P^M f(z) \geq (P^M f)^{**}(z) \geq f_{2m_1}^{**}(z) + 2m_M M^2 z^2 = r(z) + 2m_M M^2 z^2,$$

and $Q_{\mathbf{m}}f = (P^M f)^{**}$ by Proposition 2.16, in particular we have

$$\widehat{Q}_{\mathbf{m}}f(S_h) = (P^M f)^{**}(S_h) = P^M f(S_h) = r(S_h) + 2m_M M^2 S_h^2,$$

from which we get

$$Q_{\mathbf{m}}f(S_h) = r(S_h) - 2m_1 S_h^2.$$

If $h \in \{1, \dots, M-1\}$ we have

$$f(S_h) + 2m_1 S_h^2 = f_{2m_1}(S_h) > f_{2m_1}^{**}(S_h) = r(S_h)$$

which implies

$$f(S_h) > r(S_h) - 2m_1 S_h^2 = Q_{\mathbf{m}}f(S_h),$$

which contradicts the stability of f .

Note that indeed

$$\widehat{Q}_{\mathbf{m}}f(z) > r(z) + 2m_M M^2 z^2 \text{ if } z \in (S_h, S_{h+1}). \quad (2.27)$$

To check this observe that, since $\widehat{Q}_{\mathbf{m}}f(z) = (P^M f)^{**}(z)$, there exist $z_1, z_2 \in [S_h, S_{h+1}]$ and $t \in [0, 1]$ such that $z = tz_1 + (1-t)z_2$ and

$$\begin{aligned}\widehat{Q}_{\mathbf{m}}f(z) &= tP^M f(z_1) + (1-t)P^M f(z_2) \\ &\geq tr(z_1) + (1-t)r(z_2) + t2m_M M^2 z_1^2 + (1-t)2m_M M^2 z_2^2,\end{aligned}$$

and we get (2.27) unless $z_1 = z_2 = z$. The latter case is ruled out, as we would have $\widehat{Q}_{\mathbf{m}}f(z) = tP^M f(z)$; that is, $z \in \{S_h, S_{h+1}\}$.

(ii) We fix $h \in \{0, \dots, M-1\}$ and consider any interval (S_h, S_{h+1}) as defined in the proof of claim (i) above. If $z \in (S_h, S_{h+1})$, by (2.27) we have

$$\begin{aligned}Q_{\mathbf{m}}f(z) + 2m_1 z^2 &= \widehat{Q}_{\mathbf{m}}f(z) - 2m_M M^2 z^2 \\ &> r(z) = f_{2m_1}^{**}(z) = (f(z) + 2m_1 z^2)^{**} \\ &\geq (Q_{\mathbf{m}}f(z) + 2m_1 z^2)^{**}.\end{aligned}\tag{2.28}$$

Hence, each (S_h, S_{h+1}) is an interval of non-convexity of $Q_{\mathbf{m}}f(z) + 2m_1 z^2$ and we may repeat the argument of the proof of claim (i) to show that $Q_{\mathbf{m}}^f(z) > Q_{\mathbf{m}}^2 f(z)$ in $M-1$ equi-spaced points in (S_h, S_{h+1}) . The argument can be then used iteratively.

(iii) If f_{2m_1} is convex the claim is trivial. Suppose otherwise. By (2.28) we have

$$(f(z) + 2m_1 z^2)^{**} = (Q_{\mathbf{m}}f(z) + 2m_1 z^2)^{**} = r(z)$$

for $z \in [S_0, S_M]$, and, iterating the argument also

$$r(z) = (f(z) + 2m_1 z^2)^{**} = (Q_{\mathbf{m}}^n f(z) + 2m_1 z^2)^{**},$$

for $z \in [S_0, S_M]$ and $n \geq 1$. As in the proof of claim (ii) above we have

$$Q_{\mathbf{m}}^n f(z) + 2m_1 z^2 = r(z) \quad \text{if } z = S_0 + \frac{k}{M^n}(S_M - S_0)$$

for all $k \leq M^n$, and then

$$Q_{\mathbf{m}}^\infty f(z) + 2m_1 z^2 = r(z) \quad \text{if } z = S_0 + \frac{k}{M^n}(S_M - S_0)$$

for some n and for all $k \leq M^n$. By density, the equality then extends to all $z \in [S_0, S_M]$. Arguing in this way in each interval of non-convexity of f_{2m_1} we conclude. \square

Corollary 2.34. *The same claims of the previous proposition hold if \mathbf{m} is such that $M \geq 2$ exists such that $m_n = 0$ if $n \notin \{1, MN\}$.*

Proof. The proof follows by noting that

$$\sum_{i,j=0}^k m_{|i-j|} (u_i - u_j)^2 \leq 2m_1 \sum_{i=1}^k (u_i - u_{i-1})^2 + \tilde{m}_M \sum_{i,j=0, |i-j|=M}^k (u_i - u_j)^2,$$

where $\tilde{m}_M = \sum_{j=1}^{\infty} j^2 m_{jM}$, and arguing by comparison, applying the previous proposition to the kernel $\tilde{\mathbf{m}}$ where $\tilde{m}_1 = m_1$ and $\tilde{m}_n = 0$ if $n \notin \{1, M\}$ \square

Proposition 2.33 does not hold for ‘incommensurate’ kernels; i.e., such that there are interactions not multiple of a common $M > 1$. In the example below we treat a paradigmatic case.

Example 2.35 (incommensurability and non-trivial \mathbf{m} -stability). Let \mathbf{m} be such that $m_n \neq 0$ if and only if $n \in \{2, 3\}$.

Let $k \in \mathbb{N}$ and consider the quadratic function

$$G(z_1, \dots, z_k) = 2m_2 \sum_{i=1}^k (z_i + z_{i+1})^2 + 2m_3 \sum_{i=1}^k (z_i + z_{i+1} + z_{i+2})^2$$

defined on k periodic sequences $\{z_i\}_{i \in \mathbb{Z}}$. Using that for all $a, b \in \mathbb{R}$ we have $2(a^2 + b^2) \geq (a - b)^2$, so that

$$2m_2(z_{i+1} + z_{i+2})^2 + 2m_3(z_i + z_{i+1} + z_{i+2})^2 \geq \min\{m_2, m_3\}z_i^2,$$

we obtain that

$$H_c(z_1, \dots, z_k) = G(z_1, \dots, z_k) - 2c \sum_{i=1}^k z_i^2 \geq 0$$

for any $c \in (0, \frac{\min\{m_2, m_3\}}{2})$. Hence, since H_c is a symmetric non-negative 2-homogeneous polynomial of degree 2, it is convex. Then

$$\frac{1}{k} \min \left\{ H_c(z_1, \dots, z_k) : \sum_{i=1}^k z_i = kz \right\} = 8m_2z^2 + 18m_3z^2 - 2cz^2. \quad (2.29)$$

Now, we suppose that $f(z) + 2cz^2$ is convex for some $c \in (0, \frac{\min\{m_2, m_3\}}{2})$. Then for any k

$$\begin{aligned} & \frac{1}{k} \min \left\{ \sum_{i=1}^k f(z_i) + G(z_1, \dots, z_k) : \sum_{i=1}^k z_i = kz \right\} \\ &= \frac{1}{k} \min \left\{ \sum_{i=1}^k (f(z_i) + 2cz_i^2) + H_c(z_1, \dots, z_k) : \sum_{i=1}^k z_i = kz \right\} \\ &= f(z) + 2cz^2 + 8m_2z^2 + 18m_3z^2 - 2cz^2 = f(z) + a_{\mathbf{m}}z^2. \end{aligned}$$

Note that by Remark 2.8 in the definition of $Q_{\mathbf{m}}f$ we can take $u_i - u_{i-1} = z$ for $i = 1, 2, 3$ and $i = k, k-1, k-2$, and consider the function $u_i - u_{i-1}$ extended by k -periodicity. Indeed, the minimum problem in (2.11) is estimated from below by the periodic problem up to a term $O(\frac{1}{k})$. Hence, $\widehat{Q}_{\mathbf{m}}f(z) \geq f(z) + a_{\mathbf{m}}z^2$, and f is \mathbf{m} -stable, since the other inequality is true by (2.22). Note that this implies that in general the condition f_{2m_1} convex is not necessary for the \mathbf{m} -stability of f , since in this case it suffices that f_{2m_1+2c} be convex.

Definition 2.36 (effective strength of nearest-neighbour interaction). *Let*

$$G_k(z_1, \dots, z_k) = \sum_{n=1}^{+\infty} 2m_n \sum_{i=1}^k \left(\sum_{j=i}^{i+n} z_j \right)^2$$

defined on k -periodic sequences $\{z_j\}_{j \in \mathbb{Z}}$. We define the effective strength of nearest-neighbour interaction m_1^{eff} for \mathbf{m} as the supremum of all constant c such that

$$G_k(z_1, \dots, z_k) \geq 2c \sum_{i=1}^k z_i^2$$

for all $k \in \mathbb{N}$ and for all $\{z_j\}_{j \in \mathbb{Z}}$.

Remark 2.37 (lower bound with m_1^{eff}). Note that $m_1^{\text{eff}} \geq m_1$. The two values coincide if and only if \mathbf{m} satisfies the generalized concentration hypothesis of Corollary 2.34. Repeating the argument in Example 2.35, we obtain that a sufficient condition for the \mathbf{m} stability of a function f is the convexity of $f_{2m_1^{\text{eff}}}$. Moreover, we have the estimate

$$Q_{\mathbf{m}}f(z) \geq f_{2m_1^{\text{eff}}}^{**}(z) - 2m_1^{\text{eff}}z^2. \quad (2.30)$$

This can be achieved again following Example 2.35, estimating $f_{2m_1^{\text{eff}}}$ with its convex envelope.

2.5.1 Interpolation by parameterized kernels

The penalization kernel \mathbf{m} may depend on a scale parameter σ , measuring either the range or the scale of incompatibility. Of particular interest are kernels that tend to 0 as $\sigma \rightarrow +\infty$, while they loose their summability as $\sigma \rightarrow 0$. Kernels \mathbf{m} with such a dependence on a scale parameter σ can be used to interpolate between the extreme bounds in (2.24).

A suitable class of such kernels is constructed as follows. Let $m: [0, +\infty) \rightarrow [0, +\infty)$ be a continuous non-increasing function such that m is strictly positive up to some $\bar{x} > 0$, and

$$\int_0^{+\infty} x^2 m(x) dx < +\infty.$$

These conditions are satisfied by $m(x) = e^{-x}$; in this case, by setting $m_n = m_n^\sigma = m(\sigma n)$, we obtain the exponential kernels $m_n = e^{-\sigma n}$ studied in more detail in Section 5.

The following proposition holds.

Proposition 2.38. *Let $m: [0, +\infty) \rightarrow [0, +\infty)$ be as above, and for all $\sigma > 0$ consider the kernel $\mathbf{m}^\sigma = \{m(\sigma n)\}_n$. Let $f: \mathbb{R} \rightarrow [0, +\infty)$ satisfy growth assumptions (2.5) and (2.6). Then,*

$$\lim_{\sigma \rightarrow +\infty} Q_{\mathbf{m}^\sigma} f(z) = f^{**}(z) \quad \text{and} \quad \lim_{\sigma \rightarrow 0^+} Q_{\mathbf{m}^\sigma} f(z) = \bar{f}(z). \quad (2.31)$$

Proof. Setting $a_{\mathbf{m}^\sigma} = 2 \sum_{n=1}^{+\infty} m(\sigma n) n^2$, we obtain that

$$a_{\mathbf{m}^\sigma} \leq 2 \int_0^{+\infty} m(\sigma(x+1))(x+1)^2 dx \leq \frac{2}{\sigma} \int_0^{+\infty} m(y)y^2 dy = \frac{C}{\sigma} \rightarrow 0 \quad \text{as } \sigma \rightarrow +\infty.$$

Then, the first equality in (2.31) follows directly from Proposition 2.11, as we have

$$f^{**}(z) \leq Q_{\mathbf{m}^\sigma} f(z) \leq \psi_\sigma^{**}(z) - a_{\mathbf{m}^\sigma} z^2 \leq f(z)$$

where $\psi_\sigma(z) = f(z) + a_{\mathbf{m}^\sigma} z^2$. Since $a_{\mathbf{m}^\sigma}$ decreases to 0 as $\sigma \rightarrow +\infty$, then there exists a convex function ψ such that

$$f^{**}(z) \leq \psi(z) = \lim_{\sigma \rightarrow +\infty} \psi_\sigma^{**}(z) = \lim_{\sigma \rightarrow +\infty} \left(\psi_\sigma^{**}(z) - a_{\mathbf{m}^\sigma} z^2 \right) \leq f(z).$$

Hence, $\psi(z) = f^{**}(z) = \lim_{\sigma \rightarrow +\infty} Q_{\mathbf{m}^\sigma} f(z)$.

Now, we prove the second limit in (2.31). Since (2.14) holds, it is sufficient to show that $\lim_{\sigma \rightarrow 0} Q_{\mathbf{m}^\sigma} f(z) \geq \bar{f}(z)$. Up to scaling, we can suppose that $\bar{x} = 1$ and $m(1) = 1$. Since m is non-increasing, it is sufficient to prove the desired equality for $m = \chi_{[0,1]}$. The function $a_{\mathbf{m}^\sigma}$ is non-increasing with respect to σ ; hence, for any z there exists the limit of $Q_{\mathbf{m}^\sigma} f(z)$ as $\sigma \rightarrow 0$. Let $\sigma_k \rightarrow 0$ as $k \rightarrow +\infty$ and let u^k be a minimizer in $[0, k]$ for the minimum problem in the formula of $Q_{\mathbf{m}^{\sigma_k}}$ in Remark 2.23; that is, u^k is an admissible minimizer for $G^{\sigma_k}(u)$ defined by

$$G^{\sigma_k}(u) = \sum_{i=1}^k f(u_i - u_{i-1}) + \sum_{i,j=0}^k m(\sigma_k |i-j|) ((u_i - u_j)^2 - (i-j)^2 z^2).$$

Let $N_k = \lfloor \frac{1}{\sigma_k} \rfloor$. By Remark 2.8, we can assume that the test functions u , defined for $i \in \mathbb{Z}$, satisfy $u_i = iz$ for $i \leq N_k$ and $i \geq k - N_k$. Reasoning as in Remark 2.24, for any $\ell = 1, \dots, N_k$ and $r = 1, \dots, \ell$ we have

$$\sum_{i=1}^{\lfloor k/\ell \rfloor} \left((u_{i\ell+r}^k - u_{(i-1)\ell+r}^k)^2 - z^2 \ell^2 \right) = \sum_{i=1}^{\lfloor k/\ell \rfloor} \left(u_{i\ell+r}^k - u_{(i-1)\ell+r}^k - z\ell \right)^2 \geq 0.$$

We now define a discrete function w^k by setting $w_i^k = u_i^k - u_{i-1}^k - z$. For any $1 \leq n \leq N_k$, we can write

$$w_i^k = \sum_{j=i}^{i+n} w_j^k - \sum_{j=i+1}^{i+n} w_j^k,$$

so that, by summing over n

$$\begin{aligned} N_k \frac{1}{k} \sum_{i=1}^k (w_i^k)^2 &\leq \frac{2}{k} \sum_{n=1}^k \sum_{i=1}^k ((u_{i+n}^k - u_{i-1}^k - (n+1)z)^2 + (u_{i+n}^k - u_i^k - nz)^2) \\ &\leq \frac{4}{k} G^{\sigma_k}(u^k), \end{aligned}$$

recalling that $m(\sigma_k n) = 1$ if $\sigma_k n \leq 1$ and 0 otherwise. Now, let \tilde{u}^k denote the piecewise-affine extension to $[0, 1]$ of the discrete function defined by $\tilde{u}^k(\frac{i}{k}) = \frac{1}{k} u_i^k$, so that $(\tilde{u}^k)' - z = w_i^k$ in each interval $(\frac{i-1}{k}, \frac{i}{k})$. Since $\frac{4}{k} G^{\sigma_k}(u^k)$ is equibounded, we obtain that

$$\int_0^1 ((\tilde{u}^k)' - z)^2 dt = \frac{1}{k} \sum_{i=1}^k (w_i^k)^2 \leq \frac{C}{N_k} \rightarrow 0 \text{ as } k \rightarrow +\infty.$$

Hence, $\tilde{u}^k \rightarrow zx$ in $H^1(0, 1)$. We get

$$\begin{aligned} \lim_{k \rightarrow +\infty} Q_{\mathbf{m}^{\sigma_k}} f(z) &\geq \liminf_{k \rightarrow +\infty} \frac{1}{k} \sum_{i=1}^k f(u_i^k - u_{i-1}^k) \geq \liminf_{k \rightarrow +\infty} \frac{1}{k} \sum_{i=1}^k \bar{f}(u_i^k - u_{i-1}^k) \\ &= \liminf_{k \rightarrow +\infty} \frac{1}{k} \sum_{i=1}^k \bar{f}(w_i^k + z) = \liminf_{k \rightarrow +\infty} \int_0^1 \bar{f}(\tilde{u}_k') dt \geq \bar{f}(z), \end{aligned}$$

by the lower-semicontinuity of the functional $w \mapsto \int_0^1 \bar{f}(w') dt$ with respect to the strong H^1 -convergence. \square

Remark 2.39 ('singular' kernels depending on σ). If \mathbf{m} is a kernel concentrated at some $M \geq 2$, with $m_M \neq 0$, we consider a different type of parameter dependence. In this case, we can set $\mathbf{m}^\sigma = \{m_n^\sigma\}_n = \{\phi(\sigma)m_n\}_n$, with ϕ decreasing and such that $\lim_{\sigma \rightarrow 0^+} \phi(\sigma) = +\infty$ and $\lim_{\sigma \rightarrow +\infty} \phi(\sigma) = 0$; for instance, we may consider

$$m_n^\sigma = \frac{1}{\sigma} m_n.$$

Since m_n is not decreasing, this case cannot be treated directly by applying the result of the above proposition. However, the same argument as in the proof of Proposition 2.38 can be used as well giving

$$\lim_{\sigma \rightarrow +\infty} Q_{\mathbf{m}^\sigma} f(z) = f^{**}(z). \quad (2.32)$$

As for the limit as $\sigma \rightarrow 0^+$, we can follow the proof up to the definition of w_i^k , obtaining

$$\begin{aligned} \frac{1}{k} \sum_{i=1}^k (w_i^k)^2 &\leq \frac{2}{k} \sum_{n=1, M}^k \sum_{i=1}^k ((u_{i+n}^k - u_{i-1}^k - (n+1)z)^2 + (u_{i+n}^k - u_i^k - nz)^2) \\ &\leq \max \left\{ \frac{\sigma_k}{m_1}, \frac{\sigma_k}{m_M} \right\} \frac{4}{k} G^{\sigma_k}(u^k), \end{aligned}$$

and we can conclude exactly as above, proving that

$$\lim_{\sigma \rightarrow 0^+} Q_{\mathbf{m}^\sigma} f(z) = \bar{f}(z). \quad (2.33)$$

Note that if $m_1 = 0$ equality (2.33) in general does not hold (while (2.33) is always valid). As an example, we refer to Remark 4.6.

In general, for σ -dependent kernels equalities (2.31) are achieved only asymptotically. However, in some cases they are reached for some finite values of $\sigma > 0$. To highlight this fact, we give the following definition.

Definition 2.40 (critical transition value of σ). *Let $f: \mathbb{R} \rightarrow [0, +\infty)$ be a continuous function satisfying growth assumptions (2.5) and (2.6). Let $\{\mathbf{m}^\sigma\}_{\sigma > 0}$ be a family of parameterized kernels. We define the critical transition value of σ by setting*

$$\sigma_c = \sigma_c(f) = \sup\{\sigma > 0 : Q_{\mathbf{m}^\tau} f = f \text{ for all } \tau < \sigma\}.$$

We set $\sigma_c = 0$ if $Q_{\mathbf{m}^\sigma} f < f$ for any σ .

Example 2.41 (existence of positive critical transition values). Let $f(z) = (1 - z^2)^2$ and let \mathbf{m} be concentrated at some $M \geq 2$, as in Remark 2.39. We set $m_1^\sigma = \frac{m_1}{\sigma}$ and $m_M^\sigma = \frac{m_M}{\sigma}$. By Remark 2.29, we have that $\sigma_c = m_1$ is the critical transition value. Note that, conversely, for any σ we have that $Q_{\mathbf{m}^\sigma} f(z) > f^{**}(z)$ for some values of z , hence the limit in (2.32) is only reached at $+\infty$.

In the sequel, an important role will be played by the two special families of kernels depending on σ , exponential and concentrated at some M , introduced above and already illustrated in Fig. 1, for which the computation of $Q_{\mathbf{m}^\sigma} f$ can be performed analytically. In both cases, we will be able to trace explicitly the role of the scale parameter σ characterizing the range/strength of the penalization kernel.

3 Description of minimizers by a phase function

In this section, we focus on the important case of ‘generalized double well’ potentials when the domain of a function f can be subdivided in two sub-domains of convexity, which in

what follows we refer to as A and $\mathbb{R} \setminus A$. We call such potentials *bi-convex* and refer to the two convex branches of f as *phases*. Given that some microstructures in such models can be interpreted as a ‘phase mixtures’, it will be convenient to introduce the ‘volume-fraction parameter’ θ representing the percentage of indices i such that $u_i - u_{i-1}$ is in the set A . The computation of minima with prescribed volume fraction θ gives an upper bound for $\widehat{Q}_{\mathbf{m}}f$.

With the introduction of θ , one can proceed in two steps. The first step involves the computation of the function $\widehat{Q}_{\mathbf{m}}f(\theta, z)$ which is obtained by a constrained minimization with prescribed θ . Then the function $\widehat{Q}_{\mathbf{m}}f$ can be obtained by a one-dimensional optimization of $\widehat{Q}_{\mathbf{m}}f(\theta, z)$ over θ , which also defines the *phase function* $\theta(z)$ such that $\widehat{Q}_{\mathbf{m}}f(\theta(z), z) = \widehat{Q}_{\mathbf{m}}f(z)$. In the problems of interest the function $\theta(z)$ will have a complex ‘staircase’ structure reflecting the existence of the *locking states* at the values of θ that are stable under variation of z .

Remark 3.1 (constrained minimization and the structure of the phase function). To understand the role of the constrained minimization producing the function $\widehat{Q}_{\mathbf{m}}f(\theta, z)$ and to reveal the link between the shape of the phase function $\theta(z)$ and the structure of the relaxed energy $\widehat{Q}_{\mathbf{m}}f$, it will be instructive to consider first the case when only M -neighbour interactions are taken into account. We recall that in this case there exists $M \geq 2$ such that $m_M \neq 0$ and $m_n = 0$ for any $n \neq M$.

Proposition 2.16 gives a formula for $\widehat{Q}_{\mathbf{m}}f(z)$. If f is bi-convex, we can subdivide its computation by introducing a dependence on the fraction θ of $z_i = u_i - u_{i-1}$ belonging to the convexity region A . More precisely, for any $n = 0, \dots, M$ we can first compute the minimum at a fixed fraction $\theta_n = \frac{n}{M}$ of z_i belonging to A . Using the convexity, such minimum problems reduce to the computation of

$$P^{M,n}(z) = \min \left\{ (1 - \theta_n)f(z^-) + \theta_n f(z^+) : z^- \leq z^*, z^+ \geq z^*, \right. \\ \left. (1 - \theta_n)z^- + \theta_n z^+ = z \right\} + 2m_M(Mz)^2. \quad (3.1)$$

The optimal bounds are then completely characterized by the functions $P^{M,n}$, in the sense that

$$\widehat{Q}_{\mathbf{m}}f(z) = \left(\min_n P^{M,n}(z) \right)^{**}.$$

We will show that all the $M + 1$ values θ_n are locking states in the sense above. These values of θ are particularly relevant since the shape of $\widehat{Q}_{\mathbf{m}}f(z)$ will be shown to depend exclusively on ‘phase mixtures’ with ‘volume fraction’ θ_n . Another property enjoyed by θ_n is that the minimum problems corresponding to values of z for which $\theta(z) = \theta_n$ admit periodic solutions.

3.1 Phase-constrained relaxation and related properties

We now give some definitions, and obtain some general bounds valid for any choice of f and \mathbf{m} .

Let $z^* \in \mathbb{R}$ and let $A = [z^*, +\infty)$. For a given $\theta \in \mathbb{Q} \cap [0, 1]$ and $N \in \mathbb{N}$ we consider the set of test functions u with a percentage θ of indices i such that $u_i - u_{i-1} \in A$. Since we need a closed condition, the form of the constraint is given as follows:

$$\begin{aligned} \mathcal{V}(N; \theta) = \{u: [0, N] \cap \mathbb{Z} \rightarrow \mathbb{R} : \#\{i : u_i - u_{i-1} > z^*\} \leq \theta N, \\ \#\{i : u_i - u_{i-1} < z^*\} \leq (1 - \theta)N\}. \end{aligned} \quad (3.2)$$

For any $z \in \mathbb{R}$ we can then define the function

$$\widehat{Q}_{\mathbf{m}}f(\theta, z) = \liminf_{\substack{N \rightarrow +\infty \\ \theta N \in \mathbb{N}}} \frac{1}{N} \inf \left\{ F_1(u; [0, N]) : u \in \mathcal{A}(N; z) \cap \mathcal{V}(N; \theta) \right\}, \quad (3.3)$$

where F_1 is the (non-scaled) functional defined for $u: [0, N] \cap \mathbb{Z} \rightarrow \mathbb{R}$ by

$$F_1(u; [0, N]) = \sum_{i=1}^N f(u_i - u_{i-1}) + \sum_{i,j=0}^N m_{|i-j|} (u_i - u_j)^2 \quad (3.4)$$

(see (2.8) with $\varepsilon = 1$ and $I = [0, N]$). In the notation $\widehat{Q}_{\mathbf{m}}f(\theta, z)$ we omit the dependence on z^* . Note that a corresponding definition could be given also for a more general set A .

In order to obtain bounds for $Q_{\mathbf{m}}f$, we also define

$$Q_{\mathbf{m}}f(\theta, z) = \widehat{Q}_{\mathbf{m}}f(\theta, z) - a_{\mathbf{m}}z^2. \quad (3.5)$$

Theorem 3.2 (optimization over the phase fraction). *The following equality holds:*

$$\inf_{\theta \in \mathbb{Q} \cap [0, 1]} \widehat{Q}_{\mathbf{m}}f(\theta, z) = \widehat{Q}_{\mathbf{m}}f(z).$$

Proof. It is sufficient to prove that $\widehat{Q}_{\mathbf{m}}f(z) \geq \inf_{\theta \in \mathbb{Q} \cap [0, 1]} \widehat{Q}_{\mathbf{m}}f(\theta, z)$. To this end, with $\eta > 0$ fixed we choose $\delta > 0$, $k \in \mathbb{N}$ and u an admissible test function for the minimum in (2.10) such that

$$\frac{1}{k} \left(\sum_{i=1}^k f(u_i - u_{i-1}) + \sum_{i,j=0}^k m_{|i-j|} (u_i - u_j)^2 \right) \leq \widehat{Q}_{\mathbf{m}}f(z) + \eta.$$

Setting

$$\theta = \frac{\#\{i : u_i - u_{i-1} \geq z^*\}}{k},$$

we extend u to \mathbb{Z} so that $u_i - zi$ is k -periodic. Since $u \in \mathcal{A}(Nk; z) \cap \mathcal{V}(Nk; \theta)$, we can use it as a test function for

$$\frac{1}{Nk} \inf \left\{ F_1(v; [0, Nk]) : v \in \mathcal{A}(Nk; z) \cap \mathcal{V}(Nk; \theta) \right\} \quad (3.6)$$

in the computation of $\widehat{Q}_{\mathbf{m}}f(\theta, z)$.

We subdivide the estimate of $F_1(v; [0, Nk])$ by grouping interactions in three (partially overlapping) different subsets taking into account the location of the interacting sites in the subintervals $[(r-1)k, rk]$ for $r \in \{1, \dots, N\}$.

i) (interactions within a single subinterval) $i, j \in [(r-1)k, rk]$ for some $r \in \{1, \dots, N\}$. Summing over all i, j and r gives the contribution

$$\frac{1}{k} F_1(u; [0, k]) \quad (3.7)$$

to (3.6).

ii) (interactions between different intervals, but not close to the endpoints) $i \in I_r^\delta = [(r-1)k + k\delta, rk - k\delta] \cap \mathbb{Z}$, $j \in I_s = [(s-1)k, sk] \cap \mathbb{Z}$ for some $r, s \in \{1, \dots, N\}$ with $r \neq s$.

Let $i' = i - (r-1)k$ and $j' = j - (s-1)k$. We can write

$$\begin{aligned} (u_i - u_j)^2 &= (u_{i'} - u_{j'} + z(r-s)k)^2 \leq 2(u_{i'} - u_{j'})^2 + 2z^2(r-s)^2k^2 \\ &\leq 2(i' - j') \sum_{l=j'+1}^{i'} (u_l - u_{l-1})^2 + 2z^2(r-s)^2k^2 \end{aligned}$$

(we can suppose for simplicity that $j' < i'$). By (2.6) we have that

$$\sum_{l=j'+1}^{i'} (u_l - u_{l-1})^2 \leq \sum_{l=1}^k (u_l - u_{l-1})^2 \leq c F_1(u; [0, k]) \leq Ck,$$

so that $(u_i - u_j)^2 \leq 2Ck^2 + 2z^2(r-s)^2k^2$.

We may suppose that k is large enough, so that $m_l \leq \frac{\eta}{l^\beta}$ if $l \geq k\delta$, where β is the decay exponent of \mathbf{m} . Note that $|i-j| \geq ||s-r| + \delta - 1|k \geq \delta k$. Hence, summing over such i, j, r and s we obtain

$$\begin{aligned} \frac{1}{Nk} \sum_{r \neq s} \sum_{i \in I_r^\delta} \sum_{j \in I_s} m_{|i-j|} (u_i - u_j)^2 &\leq \frac{1}{N} \sum_{r \neq s} 2k(C + z^2(r-s)^2) \sum_{i \in I_r^\delta} \sum_{j \in I_s} m_{|i-j|} \\ &\leq 2 \frac{1}{N} \sum_{r \neq s} (C + z^2(r-s)^2) \frac{\eta}{||s-r| + \delta - 1|^\beta} k^{3-\beta} \\ &\leq 2 \sum_{n=1}^{\infty} (C + z^2n^2) \frac{\eta}{|n + \delta - 1|^\beta} k^{3-\beta} \leq \widetilde{C}\eta. \quad (3.8) \end{aligned}$$

iii) (interactions between different intervals, close to the endpoints) $i, j \in J_r^\delta = [rk - k\delta, rk + k\delta] \cap \mathbb{Z}$ for some $r \in \{1, \dots, N-1\}$.

For such i, j we have $u_i - u_j = z(i - j)$. Hence, we have

$$\begin{aligned} \frac{1}{Nk} \sum_{r=1}^{N-1} \sum_{i,j \in J_r^\delta} m_{|i-j|} (u_i - u_j)^2 &= \frac{z^2}{Nk} \sum_{r=1}^{N-1} \sum_{i,j \in J_r^\delta} m_{|i-j|} (i - j)^2 \\ &\leq \frac{z^2}{k} \sum_{-k\delta \leq l \leq k\delta} \sum_{n \in \mathbb{Z}} m_n n^2 \leq \tilde{C}\delta. \end{aligned} \quad (3.9)$$

By (3.7)–(3.9) we obtain the estimate

$$\frac{1}{Nk} F_1(u; [0, Nk]) \leq \frac{1}{k} F_1(u; [0, k]) + \tilde{C}(\eta + \delta) \leq \widehat{Q}_{\mathbf{m}} f(z) + C(\eta + \delta).$$

Taking the liminf as $N \rightarrow +\infty$, by the arbitrariness of η and δ we obtain the claim. \square

We now study the general properties of $\widehat{Q}_{\mathbf{m}} f(\theta, z)$ as a function of θ . To that end, we write θ as the quotient of (coprime) integer numbers p and q , so that

$$\widehat{Q}_{\mathbf{m}} f(\theta, z) = \liminf_{k \rightarrow +\infty} \frac{1}{kq} \inf \left\{ F_1(u; [0, kq]) : u \in \mathcal{A}(kq; z) \cap \mathcal{V}(kq; \theta) \right\}.$$

We will need to develop some technical ideas related to the possibility of modifying boundary conditions. We note that the usual cut-off argument as in Remark 2.8 cannot be directly followed, since forcing the test function to satisfy the affine condition $u_i = iz$ near the boundary may be incompatible with the constraint. Still, we can modify the argument with a compatible condition remaining close to the affine function near the boundary.

To make this precise, for any $\delta > 0$ we introduce the set

$$\widetilde{\mathcal{A}}_\delta(N; z) = \{u \in \mathcal{A}(N; z) : |u_i - u_{i-1}| \leq |z^*| + 2|z| \text{ if } i \leq \delta N \text{ and } i \geq (1 - \delta)N\}$$

and state the following result.

Lemma 3.3 (compatible boundary conditions). *The following equality holds*

$$\widehat{Q}_{\mathbf{m}} f(\theta, z) = \lim_{\delta \rightarrow 0} \liminf_{k \rightarrow +\infty} \frac{1}{kq} \inf \left\{ F_1(u; [0, kq]) : u \in \mathcal{V}(kq; \theta) \cap \widetilde{\mathcal{A}}_\delta(kq; z) \right\}$$

for any $\theta = \frac{p}{q} \in \mathbb{Q} \cap [0, 1]$ and $z \in \mathbb{R}$.

Proof. Let $z \in \mathbb{R}$; we may suppose without loss of generality $z \leq z^*$. Let $u \in \mathcal{V}(kq; \theta) \cap \mathcal{A}(kq; z)$ be a test function. We modify u separately close to the two endpoints $i = 0$ and $i = kq$. Let u^z be a function with $u_0^z = 0$, and such that $u_i^z - u_{i-1}^z = z^*$ if $u_i - u_{i-1} \geq z^*$ and $u_i^z - u_{i-1}^z = 2z - z^*$ if $u_i - u_{i-1} \leq z^*$. By a cut-off argument as in Remark 2.8 we can modify u on $[0, 2kq\delta]$ in a function \tilde{u} in such a way that $\tilde{u}_i = u^z$ on $[0, kq\delta]$, and $\tilde{u}_i - \tilde{u}_{i-1} \notin \{u_i - u_{i-1}, u_i^z - u_{i-1}^z\}$

except for at most $kq\delta/N$ for a given arbitrary N . Since $u_i^z - u_{i-1}^z = z^*$ on a strictly positive percentage of points in $[0, kq\delta]$ (hence, we can suppose larger than $kq\delta/N$), up to slightly modifying \tilde{u} on such points we have that \tilde{u} satisfies the constraint; i.e., $\tilde{u} \in \mathcal{V}(kq; \theta)$. The same argument can be repeated close to $i = kq$. Note that the energy of u^z is comparable to that of the affine function zi , so that we obtain an estimate for the energy of \tilde{u} . \square

This lemma allows to prove the convexity of $\widehat{Q}_{\mathbf{m}}f$ in both variables.

Proposition 3.4 (convexity of $\widehat{Q}_{\mathbf{m}}f$). *The function*

$$(\theta, z) \mapsto \widehat{Q}_{\mathbf{m}}f(\theta, z)$$

is convex; more precisely,

$$(1-t)\widehat{Q}_{\mathbf{m}}f(\theta_1, z_1) + t\widehat{Q}_{\mathbf{m}}f(\theta_2, z_2) \geq \widehat{Q}_{\mathbf{m}}f((1-t)\theta_1 + t\theta_2, (1-t)z_1 + tz_2)$$

for any $t \in [0, 1] \cap \mathbb{Q}$, $\theta_h = \frac{p_h}{q_h} \in [0, 1] \cap \mathbb{Q}$ and $z_h \in \mathbb{R}$.

Proof. For any $k \in \mathbb{N}$ and $\delta > 0$ we define

$$\widehat{Q}_{\mathbf{m}}f_k^\delta(\theta, z) = \frac{1}{kq} \inf \left\{ F_1(u; [0, kq]) : u \in \mathcal{V}(kq; \theta) \cap \widetilde{\mathcal{A}}_\delta(kq; z) \right\}.$$

With fixed $\delta > 0$, we choose sequences $k_N^1, k_N^2 \rightarrow +\infty$ (omitting the dependence on δ) such that

$$\liminf_{k \rightarrow +\infty} \widehat{Q}_{\mathbf{m}}f_k^\delta(\theta_h, z_h) = \lim_{N \rightarrow +\infty} \widehat{Q}_{\mathbf{m}}f_{k_N^h}^\delta(\theta_h, z_h)$$

for $h = 1, 2$. We set $M_N^h = k_N^h q_h$. Recalling Lemma 3.3, for any fixed $\eta > 0$ we find $\delta_\eta > 0$ such that for $0 < \delta < \delta_\eta$ small enough there exists a test function $u^h \in \widetilde{\mathcal{A}}_\delta(M_N^h; z_h)$ (again omitting the dependencies) such that

$$\widehat{Q}_{\mathbf{m}}f(\theta_h, z_h) \geq \lim_{N \rightarrow +\infty} \widehat{Q}_{\mathbf{m}}f_{k_N^h}^\delta(\theta_h, z_h) - \eta = \lim_{N \rightarrow +\infty} \frac{1}{M_N^h} F_1(u^h; [0, M_N^h]) - \eta. \quad (3.10)$$

Setting $M_N = nM_N^1 M_N^2$, we define a test function u in $[0, M_N] \cap \mathbb{N}$ by means of suitable translations of u^1 and u^2 . More precisely, we set $t = \frac{m}{n}$ and

$$u_i = \begin{cases} \widehat{u}_i^1 & \text{if } i \in [0, (n-m)M_N^1 M_N^2] \\ \widehat{u}_{i-(n-m)M_N^1 M_N^2}^2 + \widehat{u}_{(n-m)M_N^1 M_N^2}^1 & \text{if } i \in ((n-m)M_N^1 M_N^2, M_N] \end{cases}$$

where $\widehat{u}^h : [0, M_N^h] \cap \mathbb{N} \rightarrow \mathbb{R}$ is given by

$$\widehat{u}^h = u_{i-(j-1)M_N^h}^h + (j-1)M_1 z_1 \quad \text{if } i \in [(j-1)M_N^h, jM_N^h]$$

with $j = 1, \dots, (n-m)M_N^2$ if $h = 1$ and $j = 1, \dots, mM_N^1$ if $h = 2$. The function u is an admissible test function for $\widehat{Q}f_{k_N^1 k_N^2}(\theta, z)$, where

$$\theta = (1-t)\theta_1 + t\theta_2 = \frac{(n-m)q_2 p_1 + mq_1 p_2}{nq_1 q_2} = \frac{p}{q} \quad \text{and} \quad z = (1-t)z_1 + tz_2.$$

Indeed, $M_N = k_N^1 k_N^2 q$, and

$$\frac{\#\{i : u_i - u_{i-1} \geq z^*\}}{M_N} = \frac{(n-m)N_2 k_N^1 p_1 + mN_1 k_N^2 p_2}{M} = \theta;$$

the boundary conditions are satisfied since $u_{M_N} = M_N z$. We get

$$\frac{1}{M_N} F_1(u; [0, M_N]) \geq \widehat{Q} \mathbf{m} f_{k_N^1 k_N^2}(\theta, z). \quad (3.11)$$

Since $u^h \in \widetilde{\mathcal{A}}_\delta(M_N^h; z)$, recalling that $m_{|i-j|} = o(|i-j|^{-\beta})$ with $\beta > 3$ we obtain

$$\begin{aligned} \frac{1}{M_N} F_1(u; [0, M_N]) &\leq \frac{(n-m)M_N^2 M_N^1}{M_N} F_1(u^1; [0, M_N^1]) + \frac{mM_N^1 M_N^2}{M_N} F_1(u^2; [0, M_N^2]) \\ &\quad + c(\delta)o(1)_{N \rightarrow +\infty} + C\delta \\ &= \frac{n-m}{n} \widehat{Q} f_{k_N^1}^\delta(\theta_1, z_1) + \frac{m}{n} \widehat{Q} f_{k_N^2}^\delta(\theta_2, z_2) + c(\delta)o(1)_{N \rightarrow +\infty} + C\delta. \end{aligned}$$

Taking the lim inf as $N \rightarrow +\infty$ and recalling (3.10) and (3.11) we get

$$\begin{aligned} \widehat{Q} \mathbf{m} f(\theta, z) &\leq \liminf_{N \rightarrow +\infty} \widehat{Q} \mathbf{m} f_{k_N^1 k_N^2}(\theta, z) \\ &\leq \liminf_{N \rightarrow +\infty} \frac{1}{M_N} F_1(u; [0, M_N]) \\ &\leq \liminf_{N \rightarrow +\infty} \left(\frac{n-m}{n} \widehat{Q} \mathbf{m} f_{k_N^1}^\delta(\theta_1, z_1) + \frac{m}{n} \widehat{Q} \mathbf{m} f_{k_N^2}^\delta(\theta_2, z_2) \right) + C\delta \\ &\leq \frac{n-m}{n} \widehat{Q} \mathbf{m} f(\theta_1, z_1) + \frac{m}{n} \widehat{Q} \mathbf{m} f(\theta_2, z_2) + \eta + C\delta. \end{aligned}$$

Since $\eta > 0$ is arbitrary and $\delta \in (0, \delta_\eta)$, this concludes the proof. \square

3.2 Phase function and locking states

By the convexity of the function $\theta \mapsto \widehat{Q} \mathbf{m} f(\theta, z)$, we can extend it (and consequently also $Q \mathbf{m} f(\theta, z)$) to the irrational values of $\theta \in (0, 1)$ by continuity. This naturally leads to a definition which singles out some critical values for θ remaining ‘stably optimal’ for a range of values of the loading parameter z .

Definition 3.5 (locking states). *We say that θ is a locking state for f and \mathbf{m} if the set $\{z : Q_{\mathbf{m}}f(\theta, z) = Q_{\mathbf{m}}f(z)\}$ contains an open interval.*

The special values of θ , for which the relaxed energy $\widehat{Q}_{\mathbf{m}}f(\theta, z)$ can be obtained by considering periodic minimizers, play a particular role in the construction of $\widehat{Q}_{\mathbf{m}}f$. Usually, the arrangements of such minimizers remain optimal over an interval of the values of z and the corresponding θ are locking states (see Remark 3.23). The analysis of some model examples from this standpoint will show how the knowledge of such special values of θ can allow one to compute the whole relaxed energy $\widehat{Q}_{\mathbf{m}}f(z)$ (for instance for concentrated kernels).

We can now introduce a ‘phase function’ as follows.

Definition 3.6 (phase function). *We define the phase (multi)function $\Theta(z)$ by*

$$\Theta(z) = \{\theta \in [0, 1] : \text{sc}(Q_{\mathbf{m}}f)(\theta, z) = Q_{\mathbf{m}}f(z)\},$$

where $\text{sc}(Q_{\mathbf{m}}f)$ denotes the lower semicontinuous envelope of $Q_{\mathbf{m}}f(\theta, z)$ with respect to θ . In order to define a phase function $\theta(z)$, we select $\theta(z)$ as the minimum of the set $\Theta(z)$.

Remark 3.7 (a selection issue). Note that in order to have θ well defined we have made a choice of $\theta(z)$ as a minimum in the case when $\Theta(z)$ is not a singleton. This is an arbitrary choice and may lead to some difficulty in the interpretation of this value, for example in cases where the dependence on $\theta \in [0, 1]$ is symmetric, or in degenerate cases (see for instance items (b) and (c) with the corresponding examples in Section 3.3.1).

Remark 3.8 (locking states as the ‘steps’ (constancy intervals) developed by $\theta(z)$). The definition of the phase function $\theta(z)$ allows one to interpret locking states as the values $\bar{\theta}$ for which $\theta^{-1}(\bar{\theta})$ contains an open interval.

Remark 3.9 (possible non-semicontinuity at the extreme points). Note that $\text{sc}(Q_{\mathbf{m}}f)(\theta, z)$ differs from $Q_{\mathbf{m}}f(\theta, z)$ only at most for $\theta \in \{0, 1\}$, by the continuity of $Q_{\mathbf{m}}f(\theta, z)$ in $(0, 1)$. If the function $\theta \mapsto Q_{\mathbf{m}}f(\theta, z)$ is lower semicontinuous in 0 and 1, then the multi-function $\Theta(z)$ coincides with the set

$$\bar{\Theta}(z) = \{\theta \in [0, 1] : Q_{\mathbf{m}}f(\theta, z) = Q_{\mathbf{m}}f(z)\}.$$

In general, the set $\bar{\Theta}(z)$ can be empty, in which case, by Definition 3.6, $\Theta(z)$ is a singleton and $\theta(z) = 0$ (or 1) if there exists $\theta_n \rightarrow 0$ (or 1, respectively) such that $Q_{\mathbf{m}}f(\theta_n, z) \rightarrow Q_{\mathbf{m}}f(z)$ (see Example 3.15 below).

Proposition 3.10. *If $\widehat{Q}_{\mathbf{m}}f$ is affine in an open interval I and $\Theta(z) = \{\theta(z)\}$ for all $z \in I$, then θ is affine in I .*

Proof. Let $z_1, z_2 \in I$, $\theta_1 = \theta(z_1)$, and $\theta_2 = \theta(z_2)$. For $t \in (0, 1)$, Proposition 3.2, the convexity of $\widehat{Q}_{\mathbf{m}}f(\theta, z)$ and the hypothesis imply that

$$\begin{aligned} \widehat{Q}_{\mathbf{m}}f(tz_1 + (1-t)z_2) &\leq \widehat{Q}_{\mathbf{m}}f(t\theta_1 + (1-t)\theta_2, tz_1 + (1-t)z_2) \\ &\leq t\widehat{Q}_{\mathbf{m}}f(\theta_1, z_1) + (1-t)\widehat{Q}_{\mathbf{m}}f(\theta_2, z_2) \\ &= t\widehat{Q}_{\mathbf{m}}f(z_1) + (1-t)\widehat{Q}_{\mathbf{m}}f(z_2) \\ &= \widehat{Q}_{\mathbf{m}}f(tz_1 + (1-t)z_2), \end{aligned}$$

and the claim follows. \square

Remark 3.11 (locking states and periodic microstructures). The definition of locking state is formally disconnected from the periodicity of the associated minimizers. However, the two notions are perhaps related. Indeed, if the value of the minimum energy $\widehat{Q}_{\mathbf{m}}f(z)$ is reached by some periodic minimizer with a given ‘pattern’ or microstructure (describing the arrangement of $u_i - u_{i-1}$ in the two energy wells), then one can expect the same pattern to be optimal also for small perturbations of z (with of course, a small variation of the values of u). This would then entail that the corresponding θ is a locking state, however, the formalization of this statement remains unproven even if it holds in all our examples.

3.3 Phase-constrained analysis for decoupled interactions

In this section we focus on the two extreme cases when the effects of f and \mathbf{m} can be decoupled; namely, either when \mathbf{m} vanishes or when f is convex. A comparison with these cases will highlight how for general f and \mathbf{m} the interplay between non-convexity and non-locality gives rise to complex superposition effects. Such effects will be analyzed in the following sections in two particularly meaningful examples.

3.3.1 Convexification as an envelope of phase-constrained problems

We start by considering the case when the kernel \mathbf{m} vanishes. We know that in this case

$$Q_{\mathbf{m}}f(z) = \widehat{Q}_{\mathbf{m}}f(z) = f^{**}(z)$$

for any z . We can still focus on the dependence of the partially relaxed energy on the volume fraction θ , which is already non trivial. Moreover, it shows some features that we will later encounter in more complex examples.

In this section, we will use $\mathbf{0}$ instead of \mathbf{m} in the notation. Suppose that while $f: \mathbb{R} \rightarrow [0, +\infty)$ is not convex, there exists $z^* \in \mathbb{R}$ such that the restrictions of f to $(-\infty, z^*]$ and $[z^*, +\infty)$ are convex. For such f , we now compute both $Q_{\mathbf{0}}f(\theta, z)$ and $\Theta(z)$.

Remark 3.12 (growth condition). The growth condition from below on $f(z)+2m_1z^2$ assumed in the previous sections, in this case would imply a growth condition on f . Nevertheless, for the results of this section it is not necessary, and below we also treat cases where it is not satisfied, showing some non-continuity effects.

Let f_0 and f_1 denote the restrictions of f to $(-\infty, z^*]$ and to $[z^*, +\infty)$, respectively. For $\theta \in (0, 1)$, by using the convexity of f_0 and f_1 we get

$$Q_{\mathbf{0}}f(\theta, z) = \inf\{(1-\theta)f_0(t) + \theta f_1(s) : t \leq z^*, s \geq z^*, (1-\theta)t + \theta s = z\}.$$

As for the limit cases $\theta = 0$ and $\theta = 1$, we have

$$Q_{\mathbf{0}}f(0, z) = \begin{cases} f_0(z) & \text{if } z \leq z^* \\ +\infty & \text{if } z > z^* \end{cases} \quad \text{and} \quad Q_{\mathbf{0}}f(1, z) = \begin{cases} +\infty & \text{if } z < z^* \\ f_1(z) & \text{if } z \geq z^*. \end{cases}$$

We subdivide the subsequent analysis in dependence of the shape of the function $f^{**}(z)$ representing the convex envelope of f ; more precisely, on whether the ‘non-convexity set’ $\{z : f^{**}(z) < f(z)\}$ is a bounded interval, a half line or the whole line. Note that in this set f^{**} is affine.

Case (a): the non-convexity set is a bounded interval. We suppose that there exist $z_0 \in (-\infty, z^*]$ and $z_1 \in [z^*, +\infty)$ such that

$$f^{**}(z) = \begin{cases} f(z) & \text{if } z \in \mathbb{R} \setminus (z_0, z_1) \\ r(z) & \text{if } z \in [z_0, z_1], \end{cases} \quad (3.12)$$

where r is affine and $r(z) < f(z)$ in (z_0, z_1) , then $Q_{\mathbf{0}}f(z)$ is obtained as a minimum of $Q_{\mathbf{0}}f(\theta, z)$. In this case, $\Theta(z)$ is a single value $\theta(z)$ for any z , and

$$\theta(z) = \begin{cases} 0 & \text{if } z \leq z_0 \\ \frac{z - z_0}{z_1 - z_0} & \text{if } z_0 \leq z \leq z_1 \\ 1 & \text{if } z \geq z_1. \end{cases}$$

Note that trivially $Q_{\mathbf{0}}f(z)$ is the convex envelope of the minimum of the two functions $Q_{\mathbf{0}}f(0, z)$ and $Q_{\mathbf{0}}f(1, z)$; that is, of $\min\{Q_{\mathbf{0}}f(\theta, z) : \theta \text{ is a locking state}\}$, since the only locking states are 0 and 1.

Note moreover that, if $\lim_{z \rightarrow +\infty} \frac{f(z)}{z} = +\infty$ and $f'_-(z^*)$ is finite, then the formula giving $Q_{\mathbf{0}}f(\theta, z)$ can be simplified for z large enough. Indeed, there exists z^+ such that for any $\theta \in (0, 1)$

$$Q_{\mathbf{0}}f(\theta, z) = (1-\theta)f_0(z^*) + \theta f_1\left(\frac{z - (1-\theta)z^*}{\theta}\right) \quad \text{if } z \geq z^+.$$

Correspondingly, if $\lim_{z \rightarrow -\infty} \frac{f(z)}{|z|} = +\infty$ and $f'_+(z^*)$ is finite then, for any $\theta \in (0, 1)$,

$$Q_{\mathbf{0}}f(\theta, z) = (1 - \theta)f_0\left(\frac{z - \theta z^*}{1 - \theta}\right) + \theta f_1(z^*) \quad \text{if } z \leq z^-$$

for $|z^-|$ large enough.

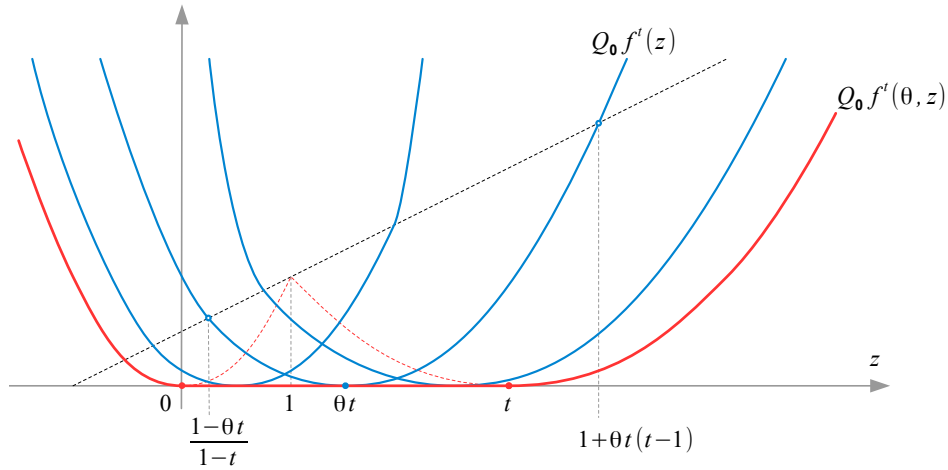

Figure 3: Graph of $Q_{\mathbf{0}}f^t(\theta, z)$ for different values of θ .

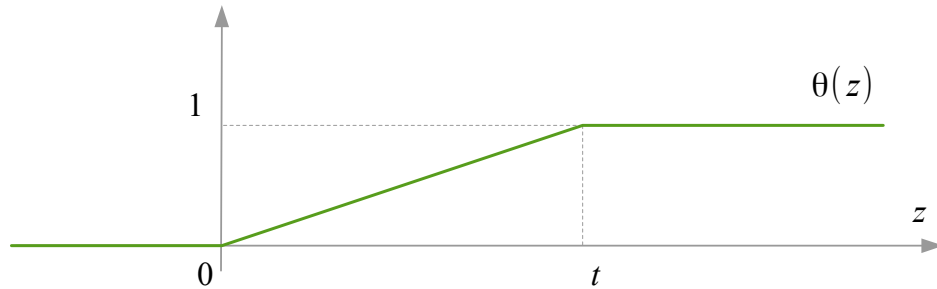

Figure 4: Graph of the phase function $\theta(z)$ for the function f^t in Example 3.13.

Example 3.13 (double-well bi-quadratic potential). For any $t > 1$ we define

$$f^t(z) = \begin{cases} z^2 & \text{if } z \leq 1 \\ \left(\frac{z-t}{1-t}\right)^2 & \text{if } z \geq 1. \end{cases}$$

If $\theta \in (0, 1)$, we get

$$Q_0 f^t(\theta, z) = \begin{cases} \frac{(z - \theta)^2}{1 - \theta} + \theta & \text{if } z \leq \frac{1 - \theta t}{1 - t} \\ \frac{(z - \theta t)^2}{1 - \theta + \theta(1 - t)^2} & \text{if } \frac{1 - \theta t}{1 - t} \leq z \leq 1 + \theta t(t - 1) \\ \frac{(z - 1 + \theta(1 - t))^2}{\theta(1 - t)^2} + 1 - \theta & \text{if } z \geq 1 + \theta t(t - 1). \end{cases}$$

In Fig. 3 we picture the graph of $Q_0 f^t(\theta, z)$ with different values of θ and t fixed, and their envelope (in red). Fig. 4 represents the graph of $\theta(z)$ for a fixed t .

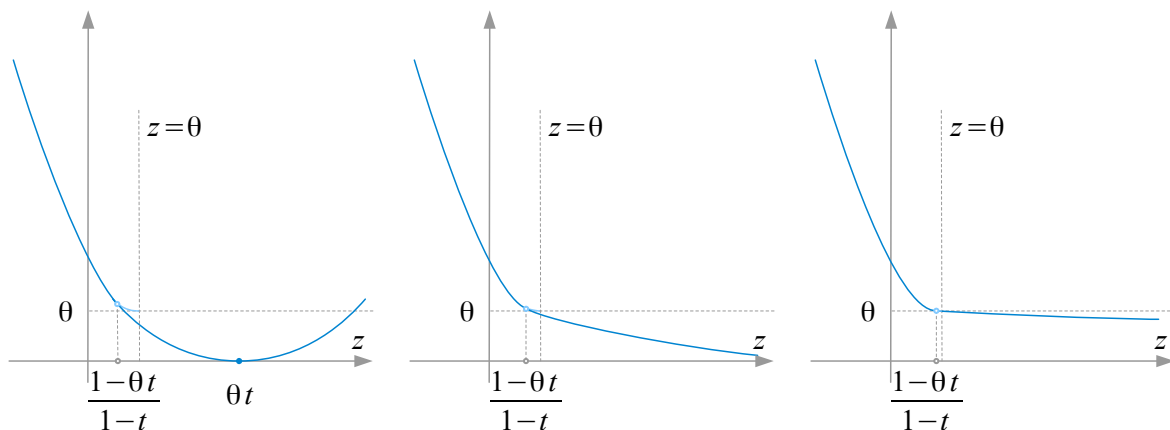

Figure 5: Graph of $Q_0 f^t(\theta, z)$ with θ fixed and increasing values of t .

In Fig. 5 we picture the graph for a fixed θ and increasing values of t .

Remark 3.14 (fracture as limit of phase transitions). If f^t is defined as in Example 3.13, then for any fixed $\theta \in (0, 1)$

$$\lim_{t \rightarrow +\infty} Q_0 f^t(\theta, z) = \begin{cases} \frac{(z - \theta)^2}{1 - \theta} + \theta & \text{if } z \leq \theta \\ \theta & \text{if } z \geq \theta. \end{cases}$$

This limit function is $Q_0 f(\theta, z)$ for f the truncated parabola (see Example 3.15 below with $\tilde{f}(z) = z^2$). This asymptotic behaviour is illustrated in Fig. 5.

From a mechanical standpoint, in the limit as $t \rightarrow +\infty$ we can recover the case fracture as limit of phase-transitions problems as the second well gets moved to the right and its curvature diminishes [96].

Case (b): the non-convexity set is a half line. Let $f^{**}(z) < f(z)$ on a half-line, and assume that the half-line is bounded from below, the other case being symmetric.

By the convexity properties of f_0 and f_1 , up to the subtraction of the affine function asymptotic to f_1 at $+\infty$, it is not restrictive to assume that $\lim_{z \rightarrow +\infty} f_1(z) \in [\min f_0, +\infty)$, so that $f^{**} = \min f_0$ in $[z_0^{\min}, +\infty)$, where z_0^{\min} is the largest minimizer of f_0 in $(-\infty, z^*]$.

For any $\theta \in (0, 1)$ and $z \geq (1 - \theta)z_0^{\min} + \theta z^*$, we can use z_0^{\min} and $\frac{z - (1 - \theta)z_0^{\min}}{\theta}$ as test values for $Q_0 f(\theta, z)$. If $z > z_0^{\min}$, taking the limit as $\theta \rightarrow 0$ we get

$$Q_0 f(z) = f_0(z_0^{\min}) = \lim_{\theta \rightarrow 0} \left((1 - \theta)f_0(z_0^{\min}) + \theta f_1\left(\frac{z - (1 - \theta)z_0^{\min}}{\theta}\right) \right) = \lim_{\theta \rightarrow 0} Q_0 f(\theta, z).$$

Since $Q_0 f(\theta, z) = +\infty$ for $z > z^* \geq z_0^{\min}$, the function $\theta \mapsto Q_0 f(\theta, z)$ is not lower semicontinuous in 0. If we also assume that $\lim_{z \rightarrow +\infty} f_1(z) > \min f_0$, then

$$Q_0 f(\theta, z) > Q_0 f(z) \text{ for any } \theta \in [0, 1] \text{ and } z > z_0^{\min}$$

and $\bar{\Theta}(z) = \emptyset$ (see Remark 3.9). Since for $z \leq z^*$ we have $Q_0 f(0, z) = Q_0 f(z)$, it follows that $\theta(z) = 0$ for any $z \leq z^*$.

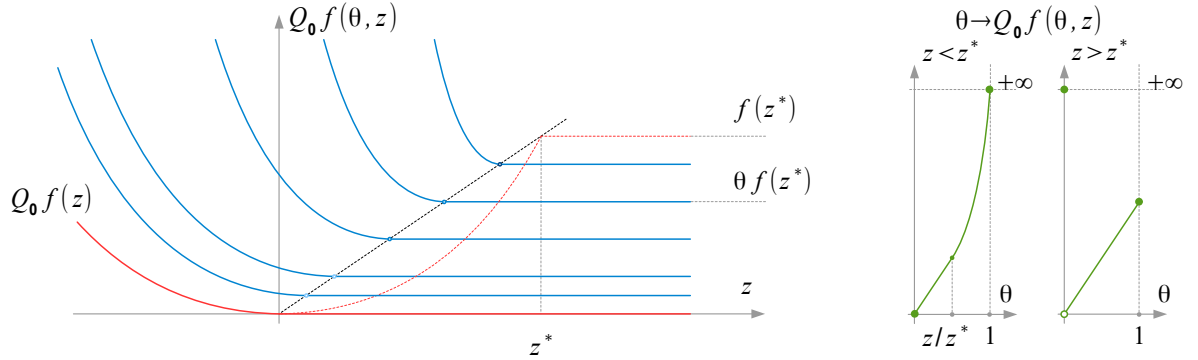

Figure 6: (a) $Q_0 f(\theta, z)$ for a truncated convex potential and (b) $\theta \mapsto Q_0 f(\theta, z)$ for different values of z .

Example 3.15 (truncated convex potential). Let f be the truncated convex given by

$$f(z) = \begin{cases} \tilde{f}(z) & \text{if } z \leq z^* \\ \tilde{f}(z^*) & \text{if } z \geq z^*, \end{cases} \quad (3.13)$$

where \tilde{f} is a convex function such that the only minimum point of \tilde{f} is 0 with $\tilde{f}(0) = 0$, and $z^* > 0$. In particular, we can take $\tilde{f}(z) = z^2$, in which case f is called a truncated quadratic

potential. For $\theta \in (0, 1)$ we get

$$Q_{\mathbf{0}}f(\theta, z) = \begin{cases} \theta f(z^*) + (1 - \theta)f\left(\frac{z - \theta z^*}{1 - \theta}\right) & \text{if } z < \theta z^* \\ \theta f(z^*) & \text{if } z \geq \theta z^*. \end{cases}$$

For all such f the graphs of $Q_{\mathbf{0}}f(\theta, z)$ and of $Q_{\mathbf{0}}f(z)$ have the form as those pictured in Fig. 6(a). In Fig. 6(b) the function $\theta \mapsto Q_{\mathbf{0}}f(\theta, z)$ is represented for two different values of z , highlighting the lack of lower semicontinuity in 0 if $z > z^*$. Note that for any $\theta \in (0, 1)$ we have $Q_{\mathbf{0}}f(\theta, z) > f(z)$ in $(-\infty, \theta z^*]$. Moreover, the optimal volume fraction $\theta(z)$ is always equal to zero, even though $Q_{\mathbf{0}}f(\theta, z) = Q_{\mathbf{0}}f(0, z)$ only if $z \leq 0$ (see Remark 3.17 below).

Case (c): the non-convexity set is the whole line. If $f^{**} < f$ in the whole \mathbb{R} , then in our hypothesis it is constant, and as in case (b) it is not restrictive to suppose that both $\lim_{z \rightarrow -\infty} f(z)$ and $\lim_{z \rightarrow +\infty} f(z)$ are finite, so that

$$Q_{\mathbf{0}}f(z) = \min\left\{\lim_{z \rightarrow -\infty} f(z), \lim_{z \rightarrow +\infty} f(z)\right\}.$$

For $\theta \in (0, 1)$,

$$Q_{\mathbf{0}}f(\theta, z) = (1 - \theta) \lim_{z \rightarrow -\infty} f(z) + \theta \lim_{z \rightarrow +\infty} f(z).$$

The function $\theta \mapsto Q_{\mathbf{0}}f(\theta, z)$ is not lower semicontinuous in 0 if $z > z^*$ and in 1 if $z < z^*$.

If $\lim_{z \rightarrow -\infty} f(z) = \lim_{z \rightarrow +\infty} f(z)$, then $Q_{\mathbf{0}}f(\theta, z) = Q_{\mathbf{0}}f(z)$ for any $\theta \in (0, 1)$ and $z \in \mathbb{R}$, hence $\Theta(z) = [0, 1]$ for any z and $\theta(z) = 0$ for any z .

If $\lim_{z \rightarrow +\infty} f(z) < \lim_{z \rightarrow -\infty} f(z)$, then for any z we have $\Theta(z) = \{1\}$ and $\theta(z) = 1$. Conversely, if $\lim_{z \rightarrow +\infty} f(z) > \lim_{z \rightarrow -\infty} f(z)$, then for any z we have $\Theta(z) = \{0\}$ and $\theta(z) = 0$. Note that $\bar{\Theta}(z) = \emptyset$ at least for any $z < z^*$ in the first case, and at least for any $z > z^*$ in the second.

We give some simple examples of case (c), highlighting the difference between Θ and $\bar{\Theta}$ due to the lack of semicontinuity at the endpoints.

Example 3.16. • If $f(z) = \min\{1, e^{-z}\}$, then $Q_{\mathbf{0}}f(z) = 0$ and $Q_{\mathbf{0}}f(\theta, z) = 1 - \theta$ for $\theta \in (0, 1)$. Since $Q_{\mathbf{0}}f(0, z)$ and $Q_{\mathbf{0}}f(1, z)$ are strictly positive, then $\bar{\Theta}(z) = \emptyset$ for any z . In this case, there is no locking state.

• If $f(z) = \max\{\min\{1, 2e^{-z} - 1\}, 0\}$, then $Q_{\mathbf{0}}f(z) = 0$ and $Q_{\mathbf{0}}f(\theta, z) = 1 - \theta$ for $\theta \in (0, 1)$ as in the previous case. In this case, $Q_{\mathbf{0}}f(1, z) = 0$ if $z \geq \log 2$, hence $\bar{\Theta}(z) = \emptyset$ for any $z < \log 2$ and $\bar{\Theta}(z) = \{1\}$ if $z \geq \log 2$. The only locking state is $\theta = 1$.

• If $f(z) = e^{-|z|}$, then $Q_{\mathbf{0}}f(z) = Q_{\mathbf{0}}f(\theta, z) = 0$ for any $\theta \in (0, 1)$ and $z \in \mathbb{R}$. The set $\bar{\Theta}(z) = (0, 1)$ for any z , while $\Theta(z) = [0, 1]$. The only locking state is $\theta = 0$.

Remark 3.17 (locking states in the degenerate cases). While we still have that trivially $Q_0f(z)$ is the convex envelope of $\min\{Q_0f(0, z), Q_0f(1, z)\}$, in the examples of cases (b) and (c) nor both values $\theta = 0$ and $\theta = 1$ are regarded as locking states. In the last of Examples 3.16 this is due to the arbitrary choice of defining $\theta(z)$ as an infimum. As a consequence, the notion of locking state is not relevant in the computation of Q_0f , in the sense that we cannot recover $Q_0f(z)$ from the only knowledge of $Q_0f(\theta, z)$ for θ locking states. In Example 3.15, indeed we have the only locking state $\theta = 0$ but $Q_0f(0, z) = +\infty$ for $z > 0$.

3.3.2 Convex potentials: phase-constrained interpolation

We now consider the second extreme case; that is, when the function f is convex on all \mathbb{R} and the kernel \mathbf{m} is arbitrary. As we noticed in Proposition 2.11, in this case the function $Q_{\mathbf{m}}f$ is trivially equal to f for any choice of \mathbf{m} . Nevertheless, the results of the constrained minimization producing the functions $Q_{\mathbf{m}}f(\theta, z)$ are non-trivial even in this case. They provide further information regarding the general structure of the dependence of $Q_{\mathbf{m}}f(\theta, z)$ on the phase variable θ . Moreover, such examples can serve as comparison limit cases for non-convex energies f .

Let $f: \mathbb{R} \rightarrow \mathbb{R}$ be a convex function while \mathbf{m} can be arbitrary. In this case, we would need the growth hypothesis $\lim_{z \rightarrow \pm\infty} f(z) + 2m_1z^2 = +\infty$ only to use some technical result concerning the variation of the boundary conditions. We fix an arbitrary $z^* \in \mathbb{R}$ and define $A = [z^*, +\infty)$.

As for $\theta = 0$ and $\theta = 1$, by definition we have

$$Q_{\mathbf{m}}f(0, z) = \begin{cases} f(z) & \text{if } z \leq z^* \\ +\infty & \text{if } z > z^* \end{cases} \quad \text{and} \quad Q_{\mathbf{m}}f(1, z) = \begin{cases} +\infty & \text{if } z < z^* \\ f(z) & \text{if } z \geq z^*. \end{cases}$$

In particular, $Q_{\mathbf{m}}f(z) = Q_{\mathbf{m}}f(0, z)$ for $z \leq z^*$ and $Q_{\mathbf{m}}f(z) = Q_{\mathbf{m}}f(1, z)$ for $z > z^*$. Moreover, the following proposition holds.

Proposition 3.18. *For $\theta \in (0, 1)$, we have*

$$Q_{\mathbf{m}}f(\theta, z) = \begin{cases} \theta f(z^*) + (1 - \theta)f\left(\frac{z - \theta z^*}{1 - \theta}\right) + a_{\mathbf{m}}\frac{\theta}{1 - \theta}(z - z^*)^2 & \text{if } z < z^* \\ (1 - \theta)f(z^*) + \theta f\left(\frac{z - (1 - \theta)z^*}{\theta}\right) + a_{\mathbf{m}}\frac{1 - \theta}{\theta}(z - z^*)^2 & \text{if } z \geq z^*. \end{cases} \quad (3.14)$$

Proof. We fix $z < z^*$. Let z_i be such that $\sum_{i=1}^{kq} z_i = kqz$, and

$$\bar{z} = \frac{1}{\#I} \sum_{i \in I} (f(z_i) + 2m_1z_i^2),$$

where $I = \{i : z_i \geq z^*\}$ and $\#I = \theta kq$. Since f is convex, we get

$$\begin{aligned} \frac{1}{kq} \sum_{i=1}^{kq} (f(z_i) + 2m_1 z_i^2) &= \frac{1}{kq} \left(\sum_{i \in I} (f(z_i) + 2m_1 z_i^2) + \sum_{i \notin I} (f(z_i) + 2m_1 z_i^2) \right) \\ &\geq \theta (f(\bar{z}) + 2m_1 \bar{z}^2) + (1 - \theta) \left(f\left(\frac{z - \theta \bar{z}}{1 - \theta}\right) + 2m_1 \left(\frac{z - \theta \bar{z}}{1 - \theta}\right)^2 \right) \\ &\geq \theta (f(z^*) + 2m_1 (z^*)^2) + (1 - \theta) \left(f\left(\frac{z - \theta z^*}{1 - \theta}\right) + 2m_1 \left(\frac{z - \theta z^*}{1 - \theta}\right)^2 \right), \end{aligned} \quad (3.15)$$

where we have used convexity in the first inequality, and the fact that $\bar{z} \geq z^*$ and $\frac{z - \theta \bar{z}}{1 - \theta} \leq \frac{z - \theta z^*}{1 - \theta}$ in the second inequality.

Let $M \in \mathbb{N}$ and $n \leq M$ be fixed. We define n partitions of the interval $[0, kq]$ given by the set of points

$$P_j = \left\{ hn + j : h = 0, \dots, \left\lfloor \frac{kq - j}{n} \right\rfloor - 1 \right\}, \quad j = 0, \dots, n - 1.$$

Let u be an admissible test function for $\widehat{Q}_{\mathbf{m}f}(\theta, z)$. Recalling Lemma 3.3, we can suppose $u \in \mathcal{V}(kq; \theta) \cap \widetilde{\mathcal{A}}_\delta(kq; z)$. With fixed n and j , let \tilde{z} and $\tilde{\theta}$ be defined by

$$\begin{aligned} u_{\lfloor \frac{kq-j}{n} \rfloor n + j} - u_j &= \left\lfloor \frac{kq - j}{n} \right\rfloor n \tilde{z} \\ \tilde{\theta} \left\lfloor \frac{kq - j}{n} \right\rfloor n &= \#\left\{ i \in \left[j, \left\lfloor \frac{kq - j}{n} \right\rfloor n + j \right] \cap \mathbb{Z} : u_i - u_{i-1} \geq z^* \right\}. \end{aligned}$$

Since $u \in \widetilde{\mathcal{A}}_\delta(kq; z)$ and $n \leq \delta kq$, we obtain $(kq - 2n)|z - \tilde{z}| \leq 4n|z| + 2n|z|$. Moreover $(kq - 2n)|\theta - \tilde{\theta}| \leq 2n + 2n\theta$, so that (uniformly with respect to n and j)

$$\tilde{z} = z + o(1)_{k \rightarrow +\infty}, \quad \tilde{\theta} = \theta + o(1)_{k \rightarrow +\infty}. \quad (3.16)$$

In particular, if k is large enough then $\tilde{z} < z^*$. By substituting to any $z_i \geq z^*$ the value z^* and to any $z_i < z^*$ the value $\frac{\tilde{z} - \tilde{\theta} z^*}{1 - \tilde{\theta}}$, the convexity of the square gives

$$\frac{1}{kq} \sum_{i \in P_j} (z_{i+1} + \dots + z_{i+n})^2 \geq \frac{1}{kq} \left\lfloor \frac{\theta kq}{n} \right\rfloor (nz^*)^2 + \frac{1}{kq} \left\lfloor \frac{(1 - \tilde{\theta})kq}{n} \right\rfloor \left(n \frac{\tilde{z} - \tilde{\theta} z^*}{1 - \tilde{\theta}} \right)^2.$$

Hence, recalling (3.16)

$$\begin{aligned} \sum_{i,j=0}^{kq} m_{|i-j|} (u_i - u_j)^2 &\geq 2 \sum_{n=1}^M m_n n \left(\left\lfloor \frac{\theta kq}{n} \right\rfloor (nz^*)^2 + \left\lfloor \frac{(1 - \tilde{\theta})kq}{n} \right\rfloor \left(n \frac{z - \theta z^*}{1 - \theta} \right)^2 \right) \\ &\quad + o(1)_{k \rightarrow +\infty} \end{aligned}$$

which, together with (3.15), gives the estimate

$$\begin{aligned} \frac{1}{kq} F_1(u; [0, kq]) &\geq \theta f(z^*) + (1 - \theta) f\left(\frac{z - \theta z^*}{1 - \theta}\right) \\ &\quad + 2 \sum_{n=1}^M m_n \left(\theta (nz^*)^2 + (1 - \theta) \left(n \frac{z - \theta z^*}{1 - \theta} \right)^2 \right) + o(1)_{k \rightarrow +\infty}. \end{aligned}$$

We obtain that

$$\widehat{Q}_{\mathbf{m}} f(\theta, z) \geq \theta f(z^*) + (1 - \theta) f\left(\frac{z - \theta z^*}{1 - \theta}\right) + 2 \sum_{n=1}^M m_n \left(\theta (nz^*)^2 + (1 - \theta) \left(n \frac{z - \theta z^*}{1 - \theta} \right)^2 \right).$$

Since M is arbitrary, we conclude that

$$Q_{\mathbf{m}} f(\theta, z) \geq \theta f(z^*) + (1 - \theta) f\left(\frac{z - \theta z^*}{1 - \theta}\right) + a_{\mathbf{m}} \left(\theta (z^*)^2 + (1 - \theta) \left(\frac{z - \theta z^*}{1 - \theta} \right)^2 \right) - a_{\mathbf{m}} z^2,$$

which gives the lower bound for (3.14) in the case $z < z^*$.

As for the upper estimate, we define a test function \bar{u} by setting

$$\bar{u}_i = \begin{cases} z^* i & \text{if } i \leq \theta kq \\ z^* \theta kq + \frac{z - \theta z^*}{1 - \theta} (i - \theta kq) & \text{if } i > \theta kq; \end{cases}$$

since $m_n = o(n^{-\beta})_{n \rightarrow +\infty}$ with $\beta > 3$ we obtain

$$\begin{aligned} \frac{1}{kq} F_1(\bar{u}; [0, kq]) &= \theta f(z^*) + (1 - \theta) f\left(\frac{z - \theta z^*}{1 - \theta}\right) \\ &\quad + 2 \sum_{n=1}^{\infty} m_n \left(\theta (nz^*)^2 + (1 - \theta) \left(n \frac{z - \theta z^*}{1 - \theta} \right)^2 \right) + o(1)_{k \rightarrow +\infty}, \end{aligned}$$

which gives the upper bound for $k \rightarrow +\infty$. Similar arguments allow one to prove (3.14) for $z > z^*$ or $z = z^*$. \square

Note that the phase multifunction $\Theta(z)$ is given by (see Fig. 7)

$$\Theta(z) = \begin{cases} \{0\} & \text{if } z < z^* \\ [0, 1] & \text{if } z = z^* \\ \{1\} & \text{if } z > z^*. \end{cases} \quad (3.17)$$

Here 0 and 1 are the only locking states.

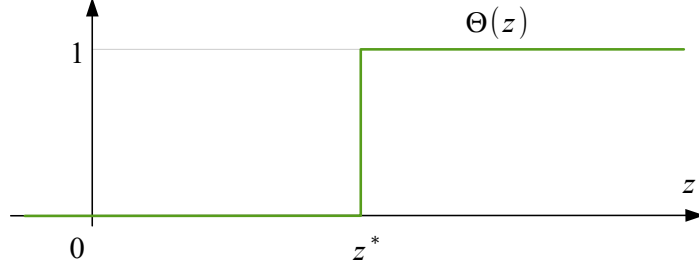

Figure 7: the phase multifunction $\Theta(z)$ in the convex case.

A particular interesting sub-case in this general class of problems is represented by semi-degenerate quadratic-affine functions, sometimes used in theories of plasticity [89]. Assume for instance that for all $\tau \in \mathbb{R}$ the function $\ell^\tau : \mathbb{R} \rightarrow \mathbb{R}$ is defined as

$$\ell^\tau(z) = \begin{cases} z^2 & \text{if } z \leq 1 \\ 2\tau(z-1) + 1 & \text{if } z > 1. \end{cases} \quad (3.18)$$

Using the general expression for $Q_{\mathbf{m}}f(\theta, z)$ in (3.14), we can now obtain an explicit formula for $Q_{\mathbf{m}}\ell^\tau(\theta, z)$ in the convex case $\tau \geq 1$, with the natural choice $A = [1, +\infty)$.

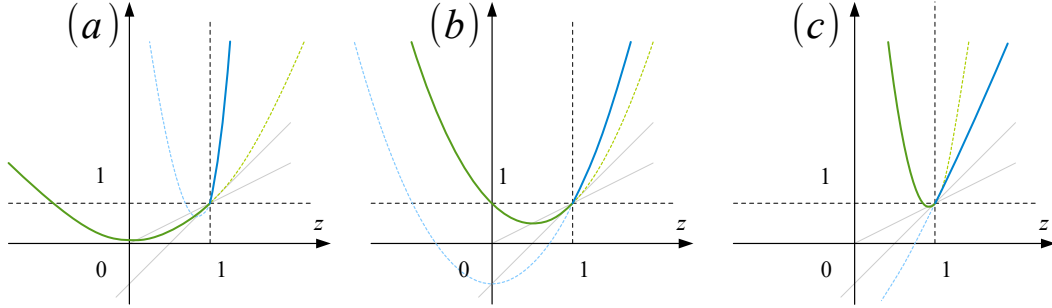

Figure 8: $Q_{\mathbf{m}}\ell^\tau(\theta, z)$ for increasing values of θ .

Example 3.19 (convex-affine potentials). Let ℓ^τ be defined as in (3.18). In the convex case $\tau \geq 1$, for any $\theta \in (0, 1)$ we have

$$Q_{\mathbf{m}}\ell^\tau(\theta, z) = \begin{cases} \frac{1 + a_{\mathbf{m}}\theta}{1 - \theta} z^2 - \frac{2(1 + a_{\mathbf{m}})\theta}{1 - \theta} z + \frac{(1 + a_{\mathbf{m}})\theta}{1 - \theta} & \text{if } z \leq 1 \\ \frac{a_{\mathbf{m}}(1 - \theta)}{\theta} z^2 - \left(\frac{2a_{\mathbf{m}}(1 - \theta)}{\theta} - \tau \right) z + 1 - 2\tau + \frac{a_{\mathbf{m}}(1 - \theta)}{\theta} & \text{if } z \geq 1 \end{cases}$$

These constructions are illustrated in Fig. 8, where we highlight the two parabolas in different colours.

In Sections 4 and 5 we will also treat the non-convex case of ℓ^τ ; that is, $\tau < 1$, with particular choices of the interaction kernel \mathbf{m} . Note that all the general results concerning ℓ^τ still hold if we take a convex \tilde{f} instead of the quadratic term.

3.4 Spin representation and optimal microstructures

We observe that for bi-convex problems a more detailed way to describe the behaviour of extremal functions is by using a two-value function which labels the position of the strain variable, whether in one or in the other of the two convex zones of f . Such ‘spin function’ can be viewed as a characteristic function of the microstructure of an extremal. Note that periodic spin functions determine a corresponding rational volume fraction θ .

To illustrate the geometry of microstructures we restate periodic minimum problems for bi-convex functions in terms of a spin representation. This procedure will allow us to rewrite non-convex minimum problems as minima of a family of convex problems, and to obtain a better control of the geometry of minimizers. We will use this formulation in some explicit examples in the next sections, to characterize optimal periodic geometries.

We begin by formally introducing the *spin variable* $\underline{s} \in \{-1, 1\}^N$ parameterizing the location of the argument of a bi-convex function f . The corresponding volume fraction is then

$$\theta = \frac{1}{2N} \sum_{j=1}^N (1 - s_j),$$

where s_j denotes the j -th component of s .

Let $f_{-1}, f_1: \mathbb{R} \rightarrow \mathbb{R}$ be such that

$$f(z) = \min\{f_{-1}(z), f_1(z)\} = \begin{cases} f_{-1}(z) & \text{if } z \in \mathbb{R} \setminus A \\ f_1(z) & \text{if } z \in A. \end{cases} \quad (3.19)$$

The slight difference in the notation with respect to previous sections, where the two functions were denoted by f_0 and f_1 , is due to the focus on individual components of the spin vector taking the values -1 and 1 . While the definitions and properties will hold without any further assumptions, in the applications we will consider the ‘natural’ case when A is a half-line and the functions f_{-1}, f_1 are convex.

Omitting the dependence on A , for $N \in \mathbb{N}$ we define $\widehat{R}_{\mathbf{m}}^N f: \{-1, 1\}^N \times \mathbb{R} \rightarrow \mathbb{R}$ by setting

$$\widehat{R}_{\mathbf{m}}^N f(\underline{s}, z) = \frac{1}{N} \inf \{F^\#(u, \underline{s}; [0, N]) : i \mapsto u_i - zi \text{ is } N\text{-periodic}\}, \quad (3.20)$$

where

$$F^\#(u, \underline{s}; [0, N]) = \sum_{i=1}^N f_{s_i}(u_i - u_{i-1}) + \sum_{i=1}^N \sum_{j \in \mathbb{Z}} m_{|i-j|} (u_i - u_j)^2.$$

Note that $\widehat{R}_{\mathbf{m}}^N f$ depends on the choice of f_1 and f_{-1} and not only on their minimum f .

Remark 3.20 (regularity with respect to z). If f_1 and f_{-1} are of class $C^1(\mathbb{R})$ then the function $z \mapsto \widehat{R}_{\mathbf{m}}^N f(\underline{s}, z)$ is of class $C^1(\mathbb{R})$ for any fixed $\underline{s} \in \{-1, 1\}^N$. This is a direct consequence of the Euler-Lagrange equations characterizing the minimum points of $F^\#$.

Now we add the phase constraint, minimizing over all \underline{s} corresponding to a given volume fraction, which eventually will give an alternative characterization of $\widehat{Q}_{\mathbf{m}} f(\theta, z)$. More precisely, fixed $\theta = \frac{p}{q} \in \mathbb{Q} \cap [0, 1]$, for any $N \in q\mathbb{Z}$ we define the function

$$\Phi_{\mathbf{m}}^N f(\theta, z) = \min\{\widehat{R}_{\mathbf{m}}^N f(\underline{s}, z) : \underline{s} \in \mathcal{S}_N(\theta)\}, \quad (3.21)$$

where $\mathcal{S}_N(\theta)$ is the set of admissible spin vectors

$$\mathcal{S}_N(\theta) = \{\underline{s} \in \{-1, 1\}^N : \#\{i : s_i = 1\} = \theta N\}$$

and again we omit the dependence on A . Moreover, we define

$$\Phi_{\mathbf{m}} f(\theta, z) = \liminf_{N \rightarrow +\infty} \Phi_{\mathbf{m}}^N f(\theta, z).$$

The following proposition states that the analysis of $\widehat{Q}_{\mathbf{m}} f(\theta, z)$ can be reduced to the periodic spin formulation giving $\Phi_{\mathbf{m}} f(\theta, z)$.

Proposition 3.21 (periodic spin characterization of $\widehat{Q}_{\mathbf{m}} f(\theta, z)$). *The following equality holds:*

$$\Phi_{\mathbf{m}} f(\theta, z) = \widehat{Q}_{\mathbf{m}} f(\theta, z)$$

In particular the function $(\theta, z) \mapsto \Phi_{\mathbf{m}} f(\theta, z)$ is convex.

Proof. The inequality $\Phi_{\mathbf{m}} f(\theta, z) \geq \widehat{Q}_{\mathbf{m}} f(\theta, z)$ directly follows by definition. Conversely, given a minimum point u for

$$\widehat{Q}_{\mathbf{m}}^{\delta, Nq} f(\theta, z) = \frac{1}{Nq} \inf \left\{ F_1(u; [0, Nq]) : u \in \widetilde{\mathcal{A}}_\delta(Nq; z) \cap \mathcal{V}(Nq; \theta) \right\},$$

we can extend it to \mathbb{Z} so that $u_i - z_i$ is Nq -periodic. Using this extended test function in the definition of $\Phi_{\mathbf{m}}^{Nq} f(\theta, z)$, with the same computations as in the proof of Lemma 3.3 we obtain

$$\Phi_{\mathbf{m}}^{Nq} f(\theta, z) \leq \widehat{Q}_{\mathbf{m}}^{\delta, Nq} f(\theta, z) + o(1)$$

as $N \rightarrow +\infty$ and $\delta \rightarrow 0$. □

We are interested in those θ for which the constrained relaxation $\widehat{Q}_{\mathbf{m}} f(\theta, z)$ is characterized by periodic minimization; that is, for which there is an interval of z such that the corresponding optimal spin function \underline{s} is periodic. Such \underline{s} will be locally z -independent, and this will allow to derive regularity properties for $\widehat{Q}_{\mathbf{m}} f(\theta, z)$. For those special values of θ , we think of such functions $\widehat{Q}_{\mathbf{m}} f(\theta, \cdot)$ as describing *energy meta-wells*. For brevity of notation, we directly say that the corresponding value of θ is an *energy well*. As we are going to show below, this concept is closely related to that of a locking state.

Definition 3.22 (energy meta-wells). *Let f be as in (3.19) and let $\Phi_{\mathbf{m}}^N$ be as in (3.21). The value $\theta \in [0, 1] \cap \mathbb{Q}$ is an energy well of f at z (related to the sequence \mathbf{m}) if there exists N such that $N\theta \in \mathbb{Z}$ and*

$$\Phi_{\mathbf{m}}^N f(\theta, z) = \Phi_{\mathbf{m}} f(\theta, z). \quad (3.22)$$

We say that θ is an energy well of f in an open interval I if there exists N such that (3.22) holds for all $z \in I$; if such I exists, we say that θ is a non-degenerate energy well of f . If $I = \mathbb{R}$, we simply say that θ is an energy well of f .

Note that the definition *a priori* depends on f_1 and f_{-1} . However, the condition that $f = \min\{f_1, f_{-1}\}$ implies that in the minimization procedure we may assume $f_1 = +\infty$ outside A and $f_{-1} = +\infty$ inside A , which shows that the definition indeed only depends on f .

Remark 3.23 (energy meta-wells and periodic solutions). By Proposition 3.21 we also have that if $\theta \in [0, 1] \cap \mathbb{Q}$ is an energy well of f at z then

$$\Phi_{\mathbf{m}}^N f(\theta, z) = \widehat{Q}_{\mathbf{m}} f(\theta, z).$$

This implies the existence of periodic minimizers; that is, of test function u_i minimizing $\widehat{Q}_{\mathbf{m}} f(\theta, z)$ with $u_i - zi$ N -periodic.

Remark 3.24. If θ is an energy well of f at z , then there exists N such that

$$\Phi_{\mathbf{m}}^{kN} f(\theta, z) = \Phi_{\mathbf{m}}^N f(\theta, z) = \Phi_{\mathbf{m}} f(\theta, z)$$

for any $k \geq 1$.

We now examine the regularity of $\Phi_{\mathbf{m}} f$ at fixed θ .

Proposition 3.25 (differentiability with respect to z). *If θ is an energy well of f in an open interval I , then the function $z \mapsto \Phi_{\mathbf{m}} f(\theta, z)$ is differentiable at any $z \in I$.*

Proof. Given θ an energy well in I and the corresponding N as in Definition 3.22, note that $z \mapsto \Phi_{\mathbf{m}} f(\theta, z)$ is the minimum of a finite number of C^1 functions, corresponding to $\underline{s} \in \mathcal{S}_N(\theta)$. Since $z \mapsto \Phi_{\mathbf{m}} f(\theta, z)$ is convex the derivatives of these functions must agree at the intersections. \square

A central question in the description of $\widehat{Q}_{\mathbf{m}} f$ is the reduction to a set X of θ such that the claim of Theorem 3.2 holds taking the infimum only on X and such that the computation of $\widehat{Q}_{\mathbf{m}} f(\theta, z)$ can be carried on for $\theta \in X$. This is the case for concentrated kernel. We will see in the examples that θ in these X are often energy wells. The following proposition shows that if such an energy well is ‘essential’ then it is a locking state.

Proposition 3.26 (energy wells and locking states). *Let $X \subset [0, 1] \cap \mathbb{Q}$ be such that*

$$\left(\inf_{\theta \in X} \{\widehat{Q}_{\mathbf{m}}f(\theta, z)\} \right)^{**} = \widehat{Q}_{\mathbf{m}}f(z) \quad (3.23)$$

for all z , and let $\theta^ \in X$ be an energy well that is essential in (3.23); that is, such that*

$$\left(\inf_{\theta \in X \setminus \{\theta^*\}} \{\widehat{Q}_{\mathbf{m}}f(\theta, z)\} \right)^{**} > \widehat{Q}_{\mathbf{m}}f(z) \quad (3.24)$$

for some z . Then, θ^ is a locking state.*

Proof. We recall that $\widehat{Q}_{\mathbf{m}}f(\theta, z) = \Phi_{\mathbf{m}}f(\theta, z)$ by Proposition 3.21. Since θ^* is an energy well, by Proposition 3.25, the function $z \mapsto \Phi_{\mathbf{m}}f(\theta^*, z)$ is differentiable. By the essentiality condition (3.24), that function cannot be tangent to $\widehat{Q}_{\mathbf{m}}f$ in an isolated point, nor can be transversal to it. Hence, it must coincide with $\widehat{Q}_{\mathbf{m}}f$ in an interval. \square

As for regularity properties of $Q_{\mathbf{m}}f$ with respect to θ , we note that in general locking states are points where the characterization of the energy changes. This suggests that we may have a jump in the derivative at these points.

Conjecture 3.27 (Non differentiability at the energy wells). *If $X \subset [0, 1] \cap \mathbb{Q}$ is such that (3.23) holds for all z and $\theta^* \in X$ is an energy well satisfying (3.24), then the function $\theta \mapsto Q_{\mathbf{m}}f(\theta, z)$ is not differentiable in z at θ^* .*

This conjecture is reminiscent of regularity properties in dynamical systems, where the global structure of minimizers can be used in the proofs, as in the work of J. Mather [79]. Anyway, we will prove that it holds in the case studies (see Remark 4.5 for the M -th neighbour case, and Remark 5.26 for the truncated convex potential and exponential kernel).

Remark 3.28 (Generalized Cauchy-Born (GCB) states). The spin representation of a microstructure allows one to effectively parametrize periodic minimizers. Such a representation can be expected to exist for locking states which can be viewed as examples of ‘global’ solutions. We can also interpret such states as respecting the generalized Cauchy-Born (GCB) rule. To make the notion of the GCB rule more general we may refer to the possibility of computing the macroscopic energy by solving an appropriate boundary value problem on a finite representative ‘cell’. The question arises in which cases any minimizer can be viewed as a GCB state in the above sense or as a simple mixture (a convex combination) of such states. We will see in the next sections that for broad classes of physically interesting non-convex energies f and the penalization kernels \mathbf{m} only GCB states are relevant.

4 Relaxation with concentrated-kernel penalization

In this section, we analyze the relaxation of a general bi-convex function f with a concentrated kernel \mathbf{m} . We recall that in this case there exists $M \neq 2$ such that $m_n = 0$ for all $n \geq 2$ except for $n = M$ and that such penalization leads to a non-additive problem (see Definition 2.15). We show that the optimal microstructures in this case are restricted to periodic states, corresponding to a fraction $\theta_n = \frac{n}{M}$ for $n \in \{0, \dots, M\}$, and compatible mixtures of such periodic states corresponding to neighbouring values of the phase fractions θ_n and θ_{n+1} , in other words, to first and second order laminates.

Following the notation of Section 3, let $z^* \in \mathbb{R}$, $A = [z^*, +\infty)$, and let $f: \mathbb{R} \rightarrow \mathbb{R}$ be such that the restrictions of f to $(-\infty, z^*]$ and $[z^*, +\infty)$ are convex. In this section, we again use the notation

$$f_{2m_1}(z) = f(z) + 2m_1z^2 \quad (4.1)$$

for the overall nearest-neighbour interactions.

We assume that growth hypothesis (2.6) holds, so that $f_{2m_1}(z) \rightarrow +\infty$ as $z \rightarrow \pm\infty$. Note that the analysis can also cover the degenerate case when this condition is not satisfied. As a model, in Remark 4.6 we will consider the case of a truncated quadratic potential f with $m_1 = 0$, highlighting the effect of degeneracy.

4.1 Formulas for the relaxation

In the case of a bi-convex f , formula of Proposition 2.16 describing $\widehat{Q}_{\mathbf{m}}f$ can be further specified as follows

$$\widehat{Q}_{\mathbf{m}}f(z) = \left(\min_n P^{M,n}(z) \right)^{**}, \quad (4.2)$$

where for any $n \in \{0, \dots, M\}$ we let $\theta_n = \frac{n}{M}$ and introduce

$$P^{M,n}(z) = \min \left\{ (1 - \theta_n)f_{2m_1}(z^-) + \theta_n f_{2m_1}(z^+) : z^- \leq z^*, z^+ \geq z^*, \right. \\ \left. (1 - \theta_n)z^- + \theta_n z^+ = z \right\} + 2m_M(Mz)^2. \quad (4.3)$$

Now we prove that for any rational θ the constrained function $\widehat{Q}_{\mathbf{m}}f(\theta, z)$, defined in (3.3), can be also characterized in terms of the functions $P^{M,n}$, which themselves correspond to particular values of θ , in the sense that $P^{M,n}(z) = \widehat{Q}_{\mathbf{m}}f(\theta_n, z)$.

Theorem 4.1 (shape of $\widehat{Q}_{\mathbf{m}}f$ and of the phase function θ). *There exists an ordered family of disjoint intervals (s_n^-, s_n^+) , where $s_0^- = -\infty$ and $s_M^+ = +\infty$, such that*

(i) $\widehat{Q}_{\mathbf{m}}f(z) = P^{M,n}(z)$ in (s_n^-, s_n^+) and it is affine in each of the intervals of the form (s_n^+, s_{n+1}^-) ;

(ii) $\theta(z) = \theta_n$ in (s_n^-, s_n^+) and it is affine in each of the remaining intervals.

(iii) the set of the locking states of f is $\{\theta_n\}$ and

$$\widehat{Q}_{\mathbf{m}}f(z) = \left(\min\{\widehat{Q}_{\mathbf{m}}f(\theta, z) : \theta \text{ is a locking state}\} \right)^{**}.$$

Proof. The proof of (i) and (ii) will follow from Lemma 4.4 below, while (iii) is obtained by (4.2). \square

Remark 4.2. Note that if $\theta(z) = \theta_n$ then the value of $\widehat{Q}_{\mathbf{m}}f(z)$ is attained on periodic minimizers. The phase function θ can be explicitly written as

$$\theta(z) = \begin{cases} \theta_n + \frac{1}{M} \frac{z - s_n^+}{s_{n+1}^- - s_n^+} & \text{if } s_n^+ \leq z \leq s_{n+1}^- \text{ for } n \in \{0, \dots, M-1\} \\ \theta_n & \text{if } s_n^- \leq z \leq s_n^+, \text{ for } n \in \{0, \dots, M\}, \end{cases} \quad (4.4)$$

with $s_0^- = -\infty$ and $s_M^+ = +\infty$. Moreover, if we write the convex envelope of the minimum of $P^{M,n}$ and $P^{M,n+1}$ as

$$\min\{P^{M,n}, P^{M,n+1}\}^{**}(z) = \begin{cases} P^{M,n}(z) & \text{if } z \leq s_n^+ \\ r^{M,n}(z) & \text{if } s_n^+ \leq z \leq s_{n+1}^- \\ P^{M,n+1}(z) & \text{if } s_{n+1}^- \leq z, \end{cases} \quad (4.5)$$

where $r^{M,n}$ is the interpolating affine function

$$r^{M,n}(z) = P^{M,n}(s_n^+) + \frac{P^{M,n+1}(s_{n+1}^-) - P^{M,n}(s_n^+)}{s_{n+1}^- - s_n^+} (z - s_n^+),$$

then $\widehat{Q}_{\mathbf{m}}f(z) = r^{M,n}(z)$ if $z \in [s_n^+, s_{n+1}^-]$. Note that this characterization of $\widehat{Q}_{\mathbf{m}}f$ holds under assumption (2.6), while it may fail if this condition is dropped, as we show in Remark 4.6 below.

The main technical point of this section is Lemma 4.4 giving an explicit formula for the constrained minimizations involving only pairs of successive locking states. The proof of this fact relies on the following algebraic lemma.

Lemma 4.3 (an algebraic lemma). *Let $n \in [0, M-1] \cap \mathbb{N}$. If $\theta = \frac{p}{q} \in [\frac{n}{M}, \frac{n+1}{M}]$, $N \in \mathbb{N}$ and I_k , for $k \in \{0, \dots, M\}$, are such that*

$$M \sum_{k=0}^M I_k = Nq \quad \text{and} \quad \sum_{k=0}^M k I_k = \theta Nq, \quad (4.6)$$

then there exist coefficients α_k^n such that $\alpha_k^n \in [0, I_k]$ for any k and

$$\begin{cases} \sum_{k=0}^M \alpha_k^n = \frac{M\theta - n}{M} Nq \\ \sum_{k=0}^M k\alpha_k^n = (n+1) \frac{M\theta - n}{M} Nq. \end{cases} \quad (4.7)$$

Proof. The linear system (4.7) has infinitely many solutions depending on $M-1$ parameters. We have to show that there exists one solution in $\Pi_{k=0}^M[0, I_k]$. To this end, it is sufficient to show that the hyperplane given by the equation

$$H_\lambda(\alpha_0^n, \dots, \alpha_M^n) = \sum_{k=0}^M (\lambda + k)\alpha_k^n - (\lambda + n + 1) \frac{M\theta - n}{M} Nq = 0$$

intersects $\Pi_{k=0}^M[0, I_k]$ for any $\lambda \in \mathbb{R}$, which happens if for any $\lambda \in \mathbb{R}$ there exist two points $v, w \in \mathbb{R}^{M+1}$ such that $H_\lambda(v) H_\lambda(w) \leq 0$. Since $n \leq M\theta \leq n+1$ and

$$H_\lambda(0, \dots, 0) = -(\lambda + n + 1) \frac{M\theta - n}{M} Nq, \quad H_\lambda(I_0^n, \dots, I_M^n) = (\lambda + n) \frac{(n+1 - M\theta)}{M} Nq,$$

we get $H_\lambda(0, \dots, 0) H_\lambda(I_0^n, \dots, I_M^n) \leq 0$ if $\lambda \leq -(n+1)$ or $\lambda \geq -n$.

For the remaining cases, we note that by (4.6)

$$(n+1) \sum_{k=0}^M (M-k)I_k - (M - (n+1)) \sum_{k=0}^M kI_k = ((n+1) - M\theta) Nq.$$

Since $(n+1)(M-k) - (M - (n+1))k = M(n+1-k) \leq 0$ if $k \geq n+1$, we get

$$\sum_{k=0}^n (n+1-k)I_k \geq \frac{(n+1) - M\theta}{M} Nq.$$

If we choose $v = (v_0, \dots, v_k)$ with $v_k = 0$ if $k \leq n$ and $v_k = I_k$ if $k > n$ we obtain

$$\begin{aligned} H_{-(n+1)}(v) &= -(n+1) \left(\sum_{k=0}^M I_k - \sum_{k=0}^n I_k \right) + \sum_{k=0}^M kI_k - \sum_{k=0}^n kI_k \\ &= \frac{M\theta - (n+1)}{M} Nq + \sum_{k=0}^n (n+1-k)I_k \geq 0. \end{aligned}$$

Noting that

$$H_{-n}(v) = \frac{M\theta - (n+1)}{M}Nq + \sum_{k=0}^n (n-k)I_k - \frac{M\theta - (n+1)}{M}Nq \geq 0,$$

it follows that $H_\lambda(v) \geq 0$ for any $\lambda \in (-(n+1), -n)$. Since $H_\lambda(0, \dots, 0) \leq 0$, this concludes the proof of Lemma 4.3. \square

Now, we state the interpolation lemma.

Lemma 4.4 (interpolation between locking states). *Let $\theta \in [\theta_n, \theta_{n+1}] \cap \mathbb{Q}$, with n integer such that $0 \leq n < M$, and $\theta_n = \frac{n}{M}$ as above. Then the following formula holds:*

$$\widehat{Q}_{\mathbf{m}}f(\theta, z) = \min \left\{ M(\theta_{n+1} - \theta)P^{M,n}(w_n) + M(\theta - \theta_n)P^{M,n+1}(w_{n+1}) : \right. \\ \left. M(\theta_{n+1} - \theta)w_n + M(\theta - \theta_n)w_{n+1} = z \right\}. \quad (4.8)$$

We mention that in view of growth condition (2.6) the minimum in (4.8) is achieved.

Proof. Up to scaling, we suppose $m_M = 1$ for notational convenience. Since Lemma 3.3 holds, for $u \in \mathcal{A}(Nq; z)$, if F_1 is the non-scaled functional given by (3.4), we can estimate $F_1(u; [0, Nq])$ as

$$\begin{aligned} F_1(u; [0, Nq]) &= \sum_{i=1}^{Nq} f(z_i) + 2m_1 \sum_{i=1}^{Nq} (z_i)^2 + \sum_{i,j=0, |i-j|=M}^{Nq} (u_i - u_j)^2 \\ &\geq \sum_{j=1}^{Nq} f_{2m_1}(z_j) + \frac{M}{Nq} \sum_{i \in M\mathbb{Z} \cap [M, Nq]} \left(\sum_{j=i-M+1}^i z_j \right)^2 + o(1)_{N \rightarrow +\infty}, \end{aligned}$$

where and $z_i = u_i - u_{i-1}$.

It is not restrictive to assume $Nq \in M\mathbb{N}$. For any $i \geq M$ we define

$$\begin{aligned} J^+(i) &= \{j \in \{i-M+1, \dots, i-1, i\} : z_j \geq z^*\} \\ J^-(i) &= \{j \in \{i-M+1, \dots, i-1, i\} : z_j < z^*\}. \end{aligned}$$

Moreover, for any $k = 0, \dots, M$ we set

$$\mathcal{I}_k = \{i \in M\mathbb{Z} \cap [M, Nq] : \#J^+(i) = k\},$$

and we denote the cardinality of \mathcal{I}_k by I_k . Let ψ_{-1} and ψ_1 denote the restrictions of f_{2m_1} to $(-\infty, z^*)$ and $[z^*, +\infty)$ respectively. Then, by separating the contributions in each \mathcal{I}_k , thanks

to the convexity of ψ_{-1} , ψ_1 and of the square we have

$$\begin{aligned}
& \sum_{j=1}^{Nq} f_{2m_1}(z_j) + \frac{M}{Nq} \sum_{i \in M\mathbb{Z} \cap [M, Nq]} \left(\sum_{j=i-M+1}^i z_j \right)^2 \\
&= \sum_{k=0}^M \sum_{i \in \mathcal{I}_k} \left(\sum_{j \in J^-(i)} \psi_{-1}(z_j) + \sum_{j \in J^+(i)} \psi_1(z_j) \right) + M \sum_{k=0}^M \sum_{i \in \mathcal{I}_k} \left(\sum_{j \in J^-(i)} z_j + \sum_{j \in J^+(i)} z_j \right)^2 \\
&\geq \sum_{k=0}^M I_k \left((M-k)(\psi_{-1}(w_k^-) + k\psi_1(w_k^+)) + M((M-k)w_k^- + kw_k^+)^2 \right) \tag{4.9}
\end{aligned}$$

where $w_M^- = w_0^+ = 0$ and

$$w_k^- = \frac{1}{(M-k)I_k} \sum_{i \in \mathcal{I}_k} \sum_{j \in J^-(i)} z_j, \quad w_k^+ = \frac{1}{kI_k} \sum_{i \in \mathcal{I}_k} \sum_{j \in J^+(i)} z_j$$

otherwise.

We now may conclude the proof of the lower bound by applying Lemma 4.3 to (4.9), since I_k satisfy (4.6), regrouping the terms therein so as to compare that expression with $P^{M,n}$. Noting that

$$\sum_{k=0}^M (M-k)\alpha_k^n = \frac{(M\theta - n)(M - (n+1))}{M} Nq,$$

we get by convexity that

$$\begin{aligned}
& \sum_{k=0}^M \alpha_k^n \left((M-k)(\psi_{-1}(w_k^-) + k\psi_1(w_k^+)) + M((M-k)w_k^- + kw_k^+)^2 \right) \\
&\geq \left(\sum_{k=0}^M (M-k)\alpha_k^n \right) \psi_{-1}(z_{n+1}^-) + \left(\sum_{k=0}^M k\alpha_k^n \right) \psi_1(z_{n+1}^+) \\
&\quad + M \left(\sum_{k=0}^M \alpha_k^n \right) \left(\frac{(\sum_{k=0}^M (M-k)\alpha_k^n) z_{n+1}^- + (\sum_{k=0}^M k\alpha_k^n) z_{n+1}^+}{\sum_{k=0}^M \alpha_k^n} \right)^2 \\
&\geq \frac{(M\theta - n)}{M} Nq \left((M - (n+1))\psi_{-1}(z_{n+1}^-) + (n+1)\psi_1(z_{n+1}^+) \right. \\
&\quad \left. + M((M - (n+1))z_{n+1}^- + (n+1)z_{n+1}^+)^2 \right),
\end{aligned}$$

where

$$z_{n+1}^- = \frac{\sum_{k=0}^M (M-k)\alpha_k^n w_k^-}{\sum_{k=0}^M (M-k)\alpha_k^n}, \quad z_{n+1}^+ = \frac{\sum_{k=0}^M k\alpha_k^n w_k^+}{\sum_{k=0}^M k\alpha_k^n}.$$

Hence,

$$\begin{aligned} & \sum_{k=0}^M \alpha_k^n \left((M-k)(\psi_{-1}(w_k^-) + k\psi_1(w_k^+) + M((M-k)w_k^- + kw_k^+)^2) \right) \\ & \geq (M\theta - n)NqP^{M,n+1} \left(\left(1 - \frac{n+1}{M}\right)z_{n+1}^- + \frac{n+1}{M}z_{n+1}^+ \right). \end{aligned}$$

Correspondingly we obtain

$$\begin{aligned} & \sum_{k=0}^M (I_k - \alpha_k^n) \left((M-k)(\psi_{-1}(w_k^-) + k\psi_1(w_k^+) + M((M-k)w_k^- + kw_k^+)^2) \right) \\ & \geq (n+1 - M\theta)NqP^{M,n} \left(\left(1 - \frac{n}{M}\right)z_n^- + \frac{n}{M}z_n^+ \right), \end{aligned}$$

where

$$z_n^- = \frac{\sum_{k=0}^M (M-k)(I_k - \alpha_k^n)w_k^-}{\sum_{k=0}^M (M-k)(I_k - \alpha_k^n)}, \quad z_n^+ = \frac{\sum_{k=0}^M k(I_k - \alpha_k^n)w_k^+}{\sum_{k=0}^M k(I_k - \alpha_k^n)}.$$

Noting that

$$\begin{aligned} & (n+1 - M\theta) \left((M-n)z_n^- + nz_n^+ \right) \\ & \quad + (M\theta - n) \left((M - (n+1))z_{n+1}^- + (n+1)z_{n+1}^+ \right) = Mz, \end{aligned}$$

for $\theta \in \left[\frac{n}{M}, \frac{n+1}{M}\right]$ we then have, up to a negligible term,

$$\begin{aligned} F_1(u; [0, Nq]) & \geq \min \left\{ (n+1 - M\theta)P^{M,n}(w_n) + (M\theta - n)P^{M,n+1}(w_{n+1}) : \right. \\ & \quad \left. (n+1 - M\theta)w_n + (M\theta - n)w_{n+1} = z \right\} \end{aligned}$$

which concludes the proof of the lower bound in (4.8).

As for the upper bound, let $\theta = \frac{p}{q} \in \left[\frac{n}{M}, \frac{n+1}{M}\right]$, $z \in \mathbb{R}$ be fixed and (w_n, w_{n+1}) be a minimizer of (4.8). For all $k \geq 1$ we define a test function $u: [0, kMq] \cap \mathbb{Z} \rightarrow \mathbb{R}$ constructed as follows. Let w_n^\pm be a minimizer of the problem defining $P^{M,n}(w_n)$ in (4.3), and let w_{n+1}^\pm be a minimizer of the corresponding problem defining $P^{M,n+1}(w_{n+1})$. We set $u_0 = 0$, and

$$\begin{aligned} u_i - u_{i-1} & = \begin{cases} w_n^+ & \text{if } i \in \{1, \dots, n\} \bmod M \\ w_n^- & \text{if } i \in \{n+1, \dots, M\} \bmod M \end{cases} & \text{for } i \leq kMq(\theta_{n+1} - \theta) \\ u_i - u_{i-1} & = \begin{cases} w_{n+1}^+ & \text{if } i \in \{1, \dots, n+1\} \bmod M \\ w_{n+1}^- & \text{if } i \in \{n+1, \dots, M\} \bmod M \end{cases} & \text{for } i > kMq(\theta_{n+1} - \theta) \end{aligned}$$

(see Fig. 9). Note that $u(kMq) = kMqz$ and $u \in \mathcal{V}(kMq; \theta)$, so that u is an admissible test function for the computation of $\widehat{Q}_{\mathbf{m}}f(\theta, z)$, and the upper bound follows. \square

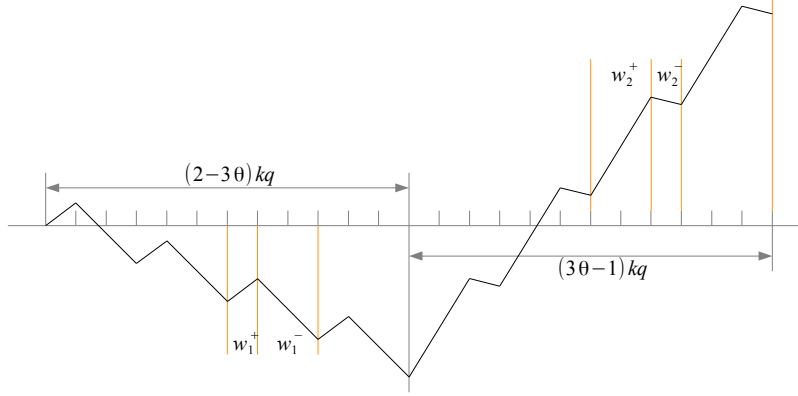

Figure 9: construction of the upper bound for $M = 3$ and $n = 1$.

Remark 4.5 (Non-differentiability at locking states). From formula (4.8) we deduce that for all z the function $\theta \mapsto Q_{\mathbf{m}}f(\theta, z)$ is differentiable at any $\theta \notin \{\theta_1, \dots, \theta_{M-1}\}$, whereas instead

$$\frac{\partial(Q_{\mathbf{m}}f)}{\partial\theta}(\theta_n^+, z) \neq \frac{\partial(Q_{\mathbf{m}}f)}{\partial\theta}(\theta_n^-, z)$$

except possibly for some critical values of z . Indeed, in the computation of the left-hand side derivative of $Q_{\mathbf{m}}f$ at $\theta = \theta_n$ we use $P^{M,n-1}$ while for the right-hand side we use $P^{M,n+1}$, whose values are generically different at the minimum points of (4.8).

4.2 Computation of $Q_{\mathbf{m}}f$ for prototypical non-convex energies

We now apply Theorem 4.1 to some prototypical f ; namely, truncated quadratic potential and double-well potential.

4.2.1 Truncated quadratic potential

We consider a special case of the truncated convex potentials introduced in Example 3.15 with $\tilde{f}(z) = z^2$ and $z^* = 1$; that is, let $f: \mathbb{R} \rightarrow \mathbb{R}$ be defined by

$$f(z) = \begin{cases} z^2 & \text{if } z \leq 1 \\ 1 & \text{if } z > 1, \end{cases} \quad (4.10)$$

and let $A = [1, +\infty)$. Note the growth assumption (2.6) implies that $m_1 > 0$.

In this case, we have

$$Q_{\mathbf{m}}f(z) = \begin{cases} z^2 & \text{if } z \leq s_0^+ \\ r^{M,n}(z) - 2(m_1 + m_M M^2)z^2 & \text{if } s_n^+ \leq z \leq s_{n+1}^- \\ \frac{2m_1(1 - \theta_n)}{2m_1 + \theta_n} z^2 + \theta_n & \text{if } s_n^- \leq z \leq s_n^+ \\ 1 & \text{if } s_M^- \leq z, \end{cases} \quad (4.11)$$

where the points s_n^+ and s_n^- in Theorem 4.1 are

$$s_n^\pm = s_n^\pm(m_1, m_M) = \frac{2m_1 + \theta_n}{\sqrt{2m_1(2m_1 + 1)}} \sqrt{\frac{m_1(2m_1 + 1) + m_M M^2(2m_1 + \theta_n) \pm m_M M}{m_1(2m_1 + 1) + m_M M^2(2m_1 + \theta_n)}} \quad (4.12)$$

and $r^{M,n}$ is the affine interpolating function in Remark 4.2. The formula for $Q_{\mathbf{m}}f$ is obtained by explicitly computing the functions $P^{M,n}(z)$ (see Appendix B).

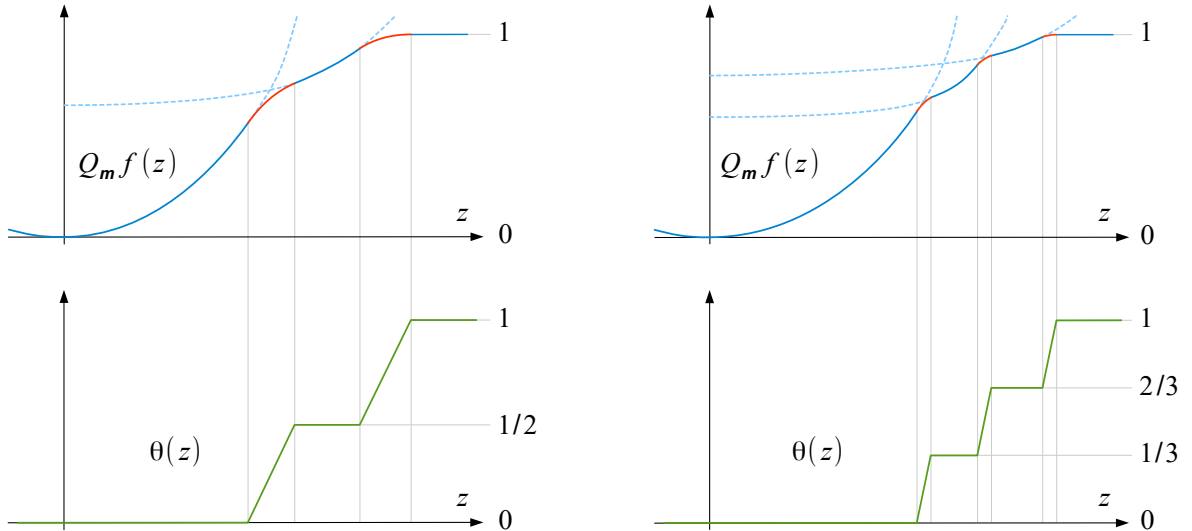

Figure 10: $Q_{\mathbf{m}}f(z)$ and $\theta(z)$ in the cases $M = 2$ (a) and $M = 3$ (b).

In Figure 10 (a)–(b), we show the structure of the functions $Q_{\mathbf{m}}f(z)$ and $\theta(z)$ in the cases $M = 2$ and $M = 3$, respectively. Here and in the following we use blue lines for convex parts of the graph and red lines for concave ones. Note that in the first case $\theta_1 = \frac{1}{2}$ corresponds to periodic minimizers of period 2 and in the second case $\theta_1 = \frac{1}{3}$ and $\theta_2 = \frac{2}{3}$ correspond to the two possible periodic minimizers of period 3. In the affine regions, we have mixtures of two periodic solutions, corresponding to neighbouring locking states.

Remark 4.6 (Degenerate case with $m_1=0$). The computation of $Q_{\mathbf{m}}f$ for the truncated quadratic potential f can be performed also in the degenerate case where the growth hypothesis (2.6) does not hold; that is, supposing $m_1 = 0$. Note that in this case there is no coercivity on the nearest-neighbour interactions.

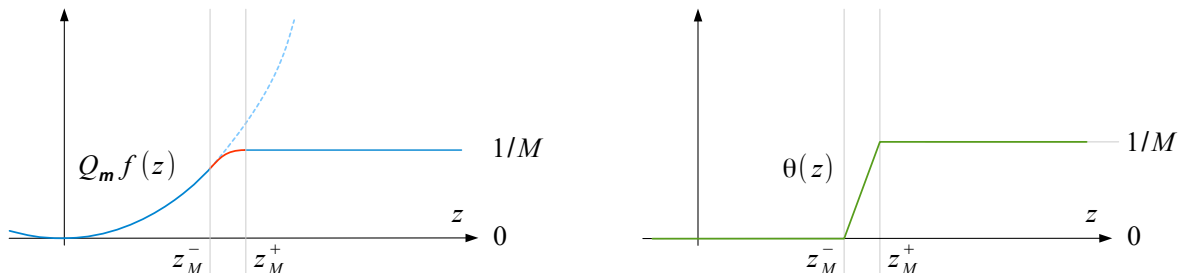

Figure 11: $Q_{\mathbf{m}}f$ and θ in a degenerate case.

The construction in Theorem 4.1 becomes degenerate, and we obtain the formula

$$Q_{\mathbf{m}}f(z) = \begin{cases} z^2 & \text{if } z \leq z_M^- \\ 2\sqrt{2m_M M(1 + 2m_M M^2)}z - 2m_M M - 2m_M M^2 z^2 & \text{if } z_M^- \leq z \leq z_M^+ \\ \frac{1}{M} & \text{if } z_M^+ \leq z, \end{cases} \quad (4.13)$$

where

$$z_M^- = \sqrt{\frac{2m_M M}{1 + 2m_M M^2}} \quad \text{and} \quad z_M^+ = \sqrt{\frac{1 + 2m_M M^2}{2m_M M^3}}.$$

The corresponding phase function is then given by $\theta(z) = 0$ if $z \leq z_M^-$, $\theta(z) = \frac{1}{M}$ if $z \geq z_M^+$ and affine otherwise, so that the locking states are $\theta = 0$ and $\theta = \frac{1}{M}$. Hence, $Q_{\mathbf{m}}f(z)$ is obtained as the convex envelope of the minimum of $P^{M,1}(z)$ and $P^{M,0}(z)$ only.

As for the description of θ as in (4.4), note that

$$\lim_{m_1 \rightarrow 0} s_0^+(m_1, m_M) = z_M^-, \quad \lim_{m_1 \rightarrow 0} s_1^-(m_1, m_M) = z_M^+,$$

while we have that as $m_1 \rightarrow 0$ then $s_n^+(m_1, m_M) \rightarrow +\infty$ for any $n \geq 1$ and $s_n^-(m_1, m_M) \rightarrow +\infty$ for any $n \geq 2$. This corresponds to the fact that the sets of z where $\theta(z) > 1/M$ tend to $+\infty$ as $m_1 \rightarrow 0$. In Fig. 11 we picture $Q_{\mathbf{m}}f$ and θ .

Remark 4.7 (Asymptotic analysis as $M \rightarrow +\infty$). In this remark we highlight the dependence of $\theta = \theta^M$ and $Q_{\mathbf{m}}f = Q^M f$ on M . We show that the limit of the functions θ^M as $M \rightarrow +\infty$ is the phase function of f when the only not vanishing coefficient is m_1 , and correspondingly for $Q^M f(z)$.

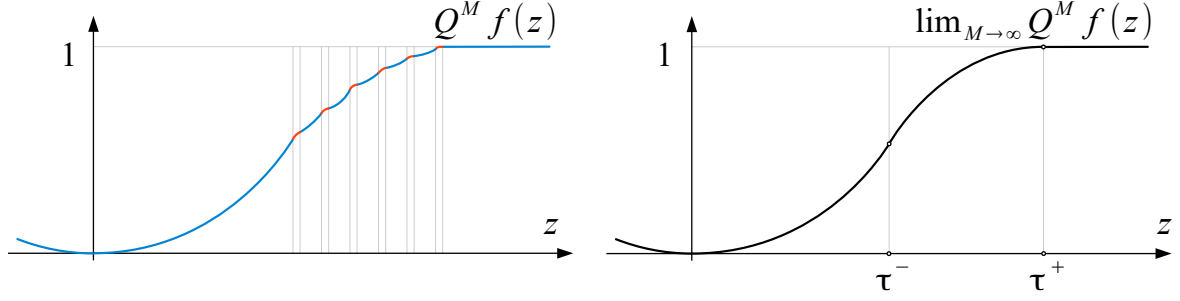

Figure 12: Graph of $Q^M f(z)$ (for $M = 6$) and of the limit function.

Indeed, the following estimates hold

$$s_n^+ \leq \frac{n + 2m_1 M + \frac{1}{2}}{\sqrt{2m_1(1 + 2m_1)}M} =: \tilde{s}_n^+, \quad s_n^- \geq \frac{n + 2m_1 M - 1}{\sqrt{2m_1(1 + 2m_1)}M} =: \tilde{s}_n^-,$$

so that we can define two piecewise-constant functions by setting

$$\bar{\theta}^M(z) = \begin{cases} 0 & \text{if } z \leq \tilde{s}_0^+ \\ \theta^M(s_{n-1}^+) & \text{if } z \in (\tilde{s}_{n-1}^+, \tilde{s}_n^+] \\ 1 & \text{if } \tilde{s}_M^+ < z \end{cases} \quad \text{and} \quad \underline{\theta}^M(z) = \begin{cases} 0 & \text{if } z \leq \tilde{s}_0^- \\ \theta^M(s_n^-) & \text{if } z \in (\tilde{s}_{n-1}^-, \tilde{s}_n^-] \\ 1 & \text{if } \tilde{s}_M^- < z, \end{cases}$$

obtaining that $\underline{\theta}^M(z) \leq \theta^M(z) \leq \bar{\theta}^M(z)$. The claim follows noting that

$$\lim_{M \rightarrow +\infty} \bar{\theta}^M(z) = \begin{cases} 0 & \text{if } z \leq \sqrt{\frac{2m_1}{1+2m_1}} \\ 2m_1 \left(z \sqrt{\frac{1+2m_1}{2m_1}} - 1 \right) & \text{if } \sqrt{\frac{2m_1}{1+2m_1}} \leq z \leq \sqrt{\frac{1+2m_1}{2m_1}} \\ 1 & \text{if } \sqrt{\frac{1+2m_1}{2m_1}} \leq z, \end{cases}$$

and the same for $\underline{\theta}^M(z)$. Correspondingly

$$\lim_{M \rightarrow +\infty} Q^M f(z) = \begin{cases} z^2 & \text{if } z \leq \sqrt{\frac{2m_1}{1+2m_1}} \\ -2m_1 \left(z^2 - 2z \sqrt{\frac{1+2m_1}{2m_1}} + 1 \right) & \text{if } \sqrt{\frac{2m_1}{1+2m_1}} \leq z \leq \sqrt{\frac{1+2m_1}{2m_1}} \\ 1 & \text{if } \sqrt{\frac{1+2m_1}{2m_1}} \leq z \end{cases}$$

(see Figure 12). In particular, we note that

$$\lim_{M \rightarrow +\infty} Q^M f(z) = (f_{2m_1})^{**}(z) - 2m_1 z^2 = Q_{\mathbf{m}'} f(z),$$

where $\mathbf{m}' = \{m_1, 0, \dots\}$.

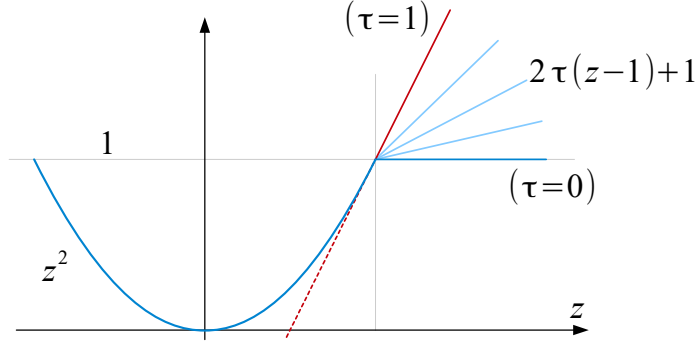

Figure 13: example of convex-affine non-convex potentials.

Example 4.8 (convex-affine potentials as perturbations of truncated potentials). We consider the functions ℓ^τ introduced in (3.18) in the non-convex case $0 \leq \tau < 1$, as pictured in Figure 13, with nearest and next-to-nearest neighbour interactions; that is, with $M = 2$. To simplify the computations, we fix $m_1 = \frac{1}{2}$ and $m_2 = \frac{1}{4}$. The computation of $Q_{\mathbf{m}}\ell^\tau(z)$ involves the values $Q_{\mathbf{m}}\ell^\tau(\theta, z)$ in the three locking states $\theta_0 = 0$, $\theta_1 = \frac{1}{2}$ and $\theta_2 = 1$; more precisely, it is sufficient to consider $Q_{\mathbf{m}}\ell^\tau(0, z) = \ell^\tau(z)$ for $z \leq 1$, $Q_{\mathbf{m}}\ell^\tau(1, z) = \ell^\tau(z)$ for $z \geq 1$ and

$$Q_{\mathbf{m}}\ell^\tau\left(\frac{1}{2}, z\right) = \frac{1}{3}z^2 + \frac{4\tau}{3}z + \frac{3 - 6\tau - \tau^2}{6}$$

for $\frac{3}{4} \leq z \leq \frac{3}{2}$. Hence

$$Q_{\mathbf{m}}\ell^\tau(z) = \begin{cases} Q_{\mathbf{m}}\ell^\tau(0, z) & \text{if } z \leq s_0^{\tau,+} \\ r_1^\tau(z) - 3z^2 & \text{if } s_0^{\tau,+} \leq z \leq s_1^{\tau,-} \\ Q_{\mathbf{m}}\ell^\tau\left(\frac{1}{2}, z\right) & \text{if } s_1^{\tau,-} \leq z \leq s_1^{\tau,+} \\ r_2^\tau(z) - 3z^2 & \text{if } s_1^{\tau,+} \leq z \leq s_2^{\tau,-} \\ Q_{\mathbf{m}}\ell^\tau(1, z) & \text{if } z \geq s_2^{\tau,-} \end{cases}$$

where $r_1^\tau(z)$ is the common tangent (in $s_0^{\tau,+}$ and $s_1^{\tau,-}$) to the parabolas $\widehat{Q}_{\mathbf{m}}\ell^\tau(0, z)$ and $\widehat{Q}_{\mathbf{m}}\ell^\tau\left(\frac{1}{2}, z\right)$, and correspondingly $r_2^\tau(z)$ is the common tangent (in $s_1^{\tau,+}$ and $s_2^{\tau,-}$) to the parabolas $\widehat{Q}_{\mathbf{m}}\ell^\tau\left(\frac{1}{2}, z\right)$ and $\widehat{Q}_{\mathbf{m}}\ell^\tau(1, z)$.

In Fig. 14 we represent $Q_{\mathbf{m}}\ell^\tau$ for two different values of τ , also showing the three energies $\widehat{Q}_{\mathbf{m}}\ell^\tau(\theta, z)$ when $\theta \in \{0, \frac{1}{2}, 1\}$, and the corresponding phase function θ . The value of τ in (b) is larger than that in (a). Note in particular that if $\tau \rightarrow 1$ then $s_2^{\tau,-} - s_0^{\tau,+} \rightarrow 0$; that is, the locking state $\theta = \frac{1}{2}$ progressively disappears, and we recover the convex case (see Example 3.19), while for $\tau = 0$ we recover the case of the truncated quadratic potential with $M = 2$.

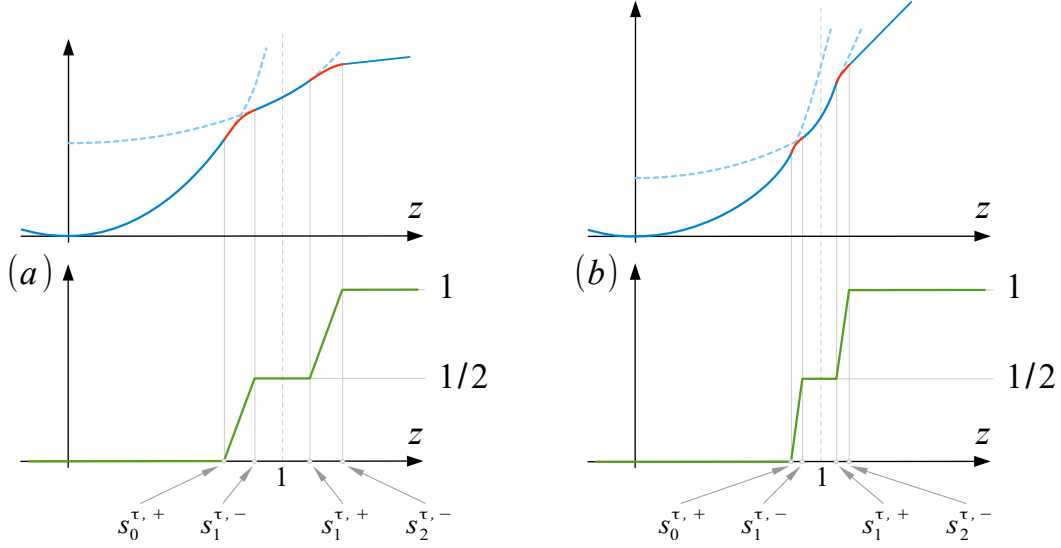

Figure 14: $Q_{\mathbf{m}}\ell^\tau$ and corresponding phase functions for increasing values of $\tau \in (0, 1)$.

4.2.2 Double-well bi-quadratic potential

Let $f: \mathbb{R} \rightarrow \mathbb{R}$ be defined by $f(z) = (1 - |z|)^2$, and let $A = [0, +\infty)$. By explicitly computing the functions $P^{M,n}$ (see Appendix B), we obtain for $Q_{\mathbf{m}}f(z)$ the formula

$$Q_{\mathbf{m}}f(z) = \begin{cases} (1+z)^2 & \text{if } z \leq s_0^+ \\ r^{M,n}(z) - 2(m_1 + m_M M^2)z^2 & \text{if } s_n^+ \leq z \leq s_{n+1}^- \\ z^2 + 2(1 - 2\theta_n)z + 1 - \frac{4\theta_n(1 - \theta_n)}{1 + 2m_1} & \text{if } s_n^- \leq z \leq s_n^+ \\ (1-z)^2 & \text{if } s_M^- \leq z, \end{cases}$$

where

$$s_n^\pm = s_n^\pm(m_1, m_M) = \frac{2\theta_n - 1}{1 + 2m_1} \pm \frac{2m_M M}{(1 + 2m_1)(1 + 2m_1 + 2m_M M^2)}$$

and $r^{M,n}$ is the interpolating affine function given in Remark 4.2.

Remark 4.9 (Asymptotic analysis as $M \rightarrow +\infty$). As in Remark 4.7, we highlight the dependence on M by writing $\theta(z) = \theta^M(z)$ and $Q_{\mathbf{m}}f(z) = Q^M f(z)$. We show that also in this case the limit of $\theta^M(z)$ as $M \rightarrow +\infty$ is the phase function of f when the only not vanishing coefficient is m_1 , and correspondingly for $Q^M f(z)$. Indeed, since the distribution of s_n^+ and

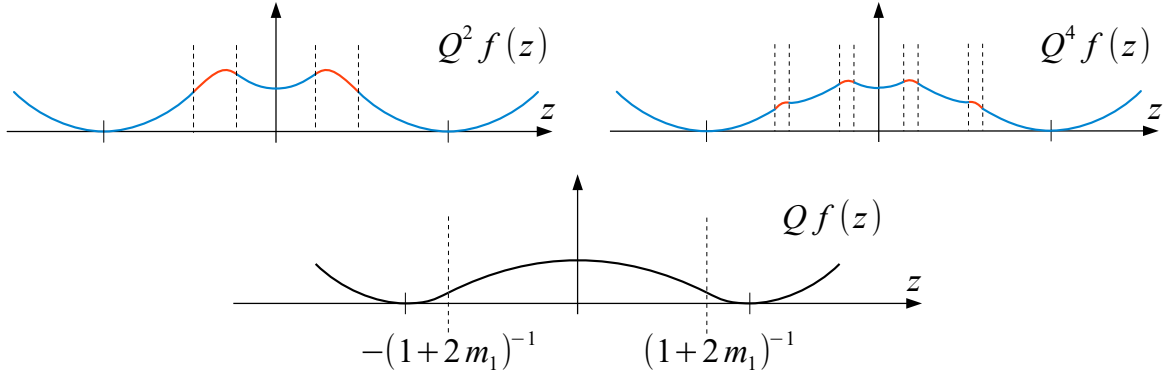

Figure 15: The function $z \mapsto Q^M f(z)$ for different values of M and the limit function.

s_n^- is uniform, we can directly deduce that

$$\lim_{M \rightarrow +\infty} \theta^M(z) = \begin{cases} 0 & \text{if } z \leq -\frac{1}{1+2m_1} \\ \frac{(1+2m_1)z+1}{2} & \text{if } |z| \leq \frac{1}{1+2m_1} \\ 1 & \text{if } z \geq \frac{1}{1+2m_1}. \end{cases}$$

Correspondingly

$$\lim_{M \rightarrow +\infty} Q^M f(z) = \begin{cases} (1+z)^2 & \text{if } z \leq -\frac{1}{1+2m_1} \\ -2m_1 z^2 + \frac{2m_1}{1+2m_1} & \text{if } |z| \leq \frac{1}{1+2m_1} \\ (1-z)^2 & \text{if } z \geq \frac{1}{1+2m_1} \end{cases}$$

(see Figure 15). Again, we note that $\lim_{M \rightarrow +\infty} Q^M f(z) = Q_{\mathbf{m}'} f(z)$, where $\mathbf{m}' = \{m_1, 0, \dots\}$.

4.2.3 Analysis of $Q_{\mathbf{m}'} f(\theta, z)$

Examining (4.8), which gives the values of $Q_{\mathbf{m}'} f(\theta, z)$ as interpolations between neighbouring locking states, we note that $Q_{\mathbf{m}'} f$ is given by different formulas in different regions of the plane (θ, z) . We briefly examine some feature of this dependence in the simplest meaningful case $M = 2$ (see also Fig. 10(a) and Fig. 15 for a comparison).

In Figures 16 (truncated quadratic potential) and 17 (double-well potential), we highlight zones with qualitatively different behaviour. In the bottom part we represent such zones in the domain of the function $[0, 1] \times \mathbb{R}$ as coloured zones. In the same pictures, the graphs of $\theta \mapsto Q_{\mathbf{m}'} f(\theta, z)$ are shown for some values of z with corresponding colouring. Note that for any fixed z the function $\theta \mapsto Q_{\mathbf{m}'} f(\theta, z)$ is differentiable everywhere (including the points where there is a change of the analytical expression), except for the point corresponding to the locking state $\theta_1 = \frac{1}{2}$, where the left and right derivative are not equal.

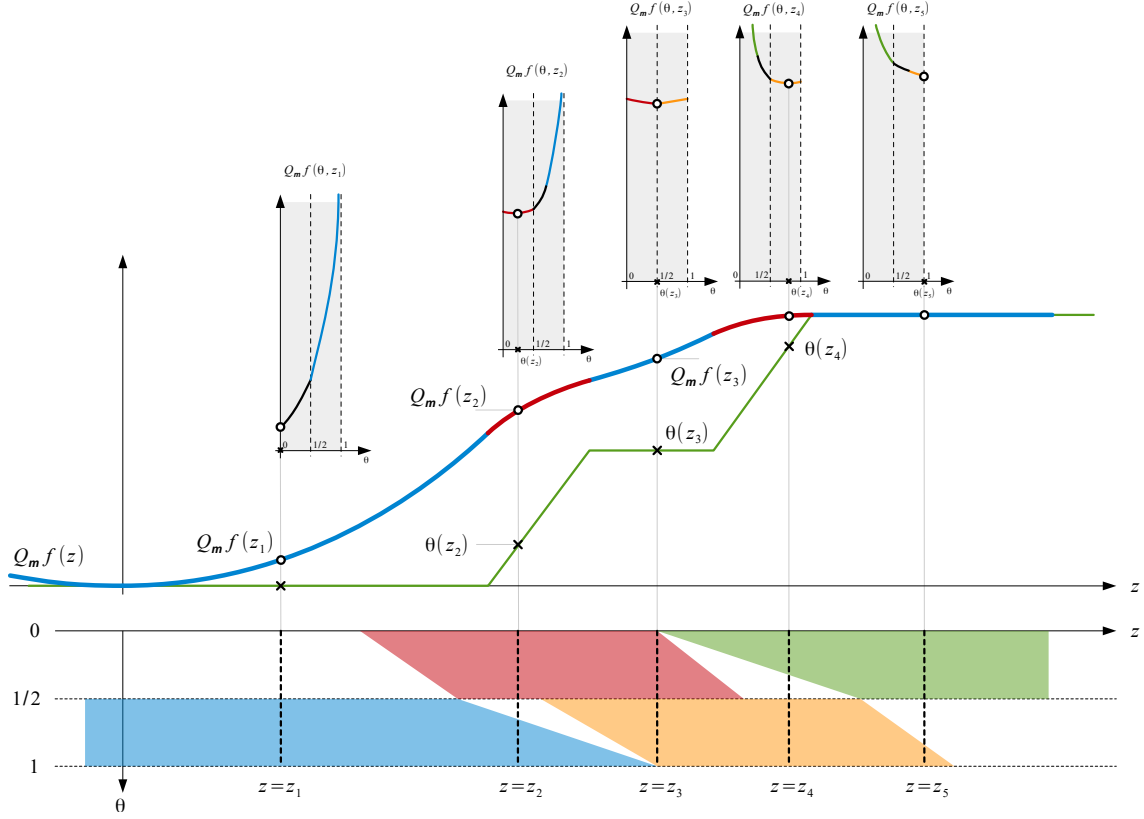

Figure 16: analysis of $\theta \mapsto Q_{\mathbf{m}}f(\theta, z)$ for different values of z in the truncated quadratic case.

For the reader's convenience, in the case of double-well potential we include an explicit formula which is particularly simple thanks to the symmetry of $Q_{\mathbf{m}}f(\theta, z)$ with respect to $(\frac{1}{2}, 0)$. We fix $m_1 = \frac{1}{2}, m_2 = \frac{1}{4}$, obtaining

$$Q_{\mathbf{m}}f(\theta, z) = \begin{cases} \frac{3z^2}{1-\theta} + 2z + 1 & \text{if } z \leq \theta - 1 \\ \frac{2z^2}{1-\theta} + \theta & \text{if } \theta - 1 < z \leq \frac{\theta-1}{2} \\ z^2 - 2(2\theta - 1)z + \theta^2 - \frac{\theta}{2} + \frac{1}{2} & \text{if } \frac{\theta-1}{2} < z \leq \frac{2\theta+1}{4} \\ \frac{12z^2}{2\theta+1} - 2z + 1 & \text{if } \frac{2\theta+1}{4} < z. \end{cases}$$

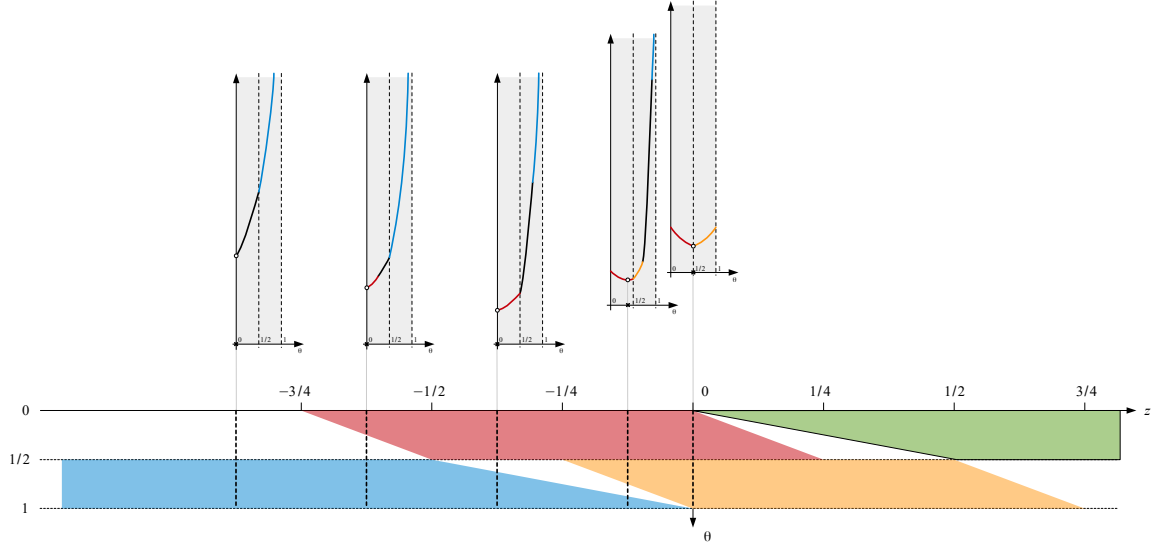

Figure 17: The function $\theta \mapsto Q_{\mathbf{m}}f(\theta, z)$ for different values of z (double-well potential).

4.2.4 Dependence on the scale parameter σ

As in Remark 2.39, we introduce a dependence of the concentrated kernel \mathbf{m} on the parameter σ by setting $m_1^\sigma = \frac{m_1}{\sigma}$ and $m_M^\sigma = \frac{m_M}{\sigma}$, for which we have

$$\lim_{\sigma \rightarrow 0^+} Q_{\mathbf{m}^\sigma} f(z) = \bar{f}(z) \quad \text{and} \quad \lim_{\sigma \rightarrow +\infty} Q_{\mathbf{m}^\sigma} f(z) = f^{**}(z) \quad (4.14)$$

for any f .

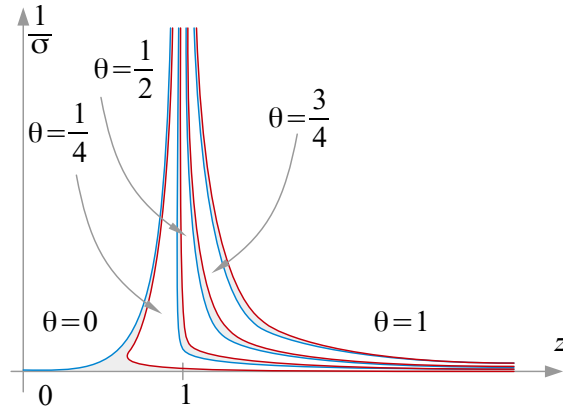

Figure 18: Representation of constancy sets of θ in the $z - \frac{1}{\sigma}$ plane ($M = 4$).

In the case of the truncated quadratic function f defined by (4.10) and analyzed in Section 4.2.1, the first limit can be also checked directly noticing that $s_n^+(m_1^\sigma, m_M^\sigma) \rightarrow 1$ as $\frac{1}{\sigma} \rightarrow +\infty$ for any n , where $s_n^+(\cdot, \cdot)$ is defined in (4.12). Note that if $\theta \in (0, 1)$ then $Q_{\mathbf{m}^\sigma} f(\theta, z) \rightarrow +\infty$ as $\frac{1}{\sigma} \rightarrow 0^+$. Moreover, for any $\theta \in (0, 1)$ and for any z ,

$$\lim_{\sigma \rightarrow +\infty} Q_{\mathbf{m}^\sigma} f(\theta, z) = Q_{\mathbf{0}} f(\theta, z) = \begin{cases} \theta + \frac{(z-\theta)^2}{1-\theta} & \text{if } z \leq \theta \\ \theta & \text{if } z \geq \theta. \end{cases}$$

In Fig. 18 we picture in the $z-\frac{1}{\sigma}$ plane the zones where $\theta(z) = \theta_n$ for some $n \in \{0, \dots, M\}$ and those where $\theta(z)$ is affine for fixed σ (in the case $M = 4$). The latter are pictured in gray, and are bounded by blue and red curves, corresponding to the lower and upper values of z , respectively (see also the right-hand side picture in Fig. 21). This use of coloring will be repeated in the next figures.

As for the double-well potential, if the coefficient m_1 does not vanish, then we re-obtain the first limit in (4.14) by noting that

$$\lim_{\sigma \rightarrow 0^+} s_n^+(m_1^\sigma, m_M^\sigma) = \lim_{\sigma \rightarrow 0^+} s_n^-(m_1^\sigma, m_M^\sigma) = 0, \quad (4.15)$$

where s_n^+ and s_n^- are defined in (B.4).

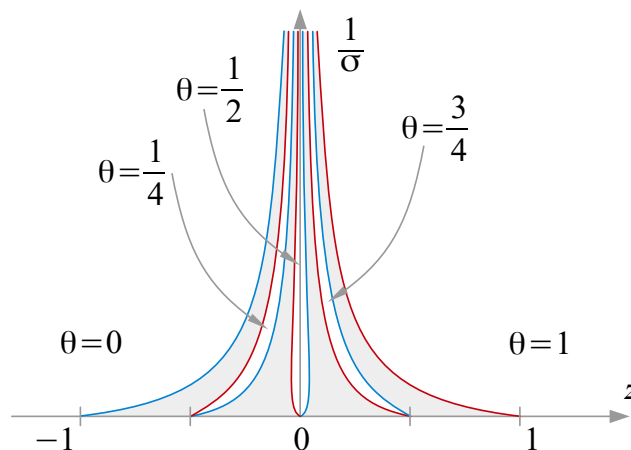

Figure 19: Representation of constancy sets of θ in the $z-\frac{1}{\sigma}$ plane ($M = 4$).

In Fig. 19 we picture in the $z-\frac{1}{\sigma}$ plane the zones where $\theta(z) = \theta_n$ for some $n \in \{0, \dots, M\}$ and those where $\theta(z)$ is affine for fixed σ (in grey) for $M = 4$.

Remark 4.10. If $m_1 = 0$, Remark 2.39 does not apply. Taking the limit for $\sigma \rightarrow 0^+$, in this case we obtain

$$\lim_{\sigma \rightarrow 0^+} s_n^+(m_1^\sigma, m_M^\sigma) = z_n, \quad \text{and} \quad \lim_{\sigma \rightarrow 0^+} s_n^-(m_1^\sigma, m_M^\sigma) = z_{n-1}, \quad (4.16)$$

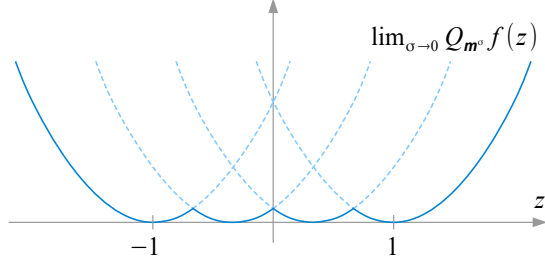

Figure 20: the limit of $Q_{m^\sigma} f$ for $\sigma \rightarrow 0$ in the case $m_1 = 0$.

where we set

$$z_n = \frac{2n + 1 - M}{M}.$$

The limit function is then given by

$$\lim_{\sigma \rightarrow 0^+} Q_{m^\sigma} f(z) = \begin{cases} (1+z)^2 & \text{if } z \leq z_0 \\ (z + (1 - 2\theta_n))^2 & \text{if } z_{n-1} \leq z \leq z_n \\ (1-z)^2 & \text{if } z_M \leq z, \end{cases}$$

or, equivalently,

$$\lim_{\sigma \rightarrow 0^+} Q_{m^\sigma} f(z) = \min_{0 \leq n \leq M} \{(z + (1 - 2\theta_n))^2\} = \min_{0 \leq n \leq M} \{Q_{m^\sigma} f(\theta_n, z)\}.$$

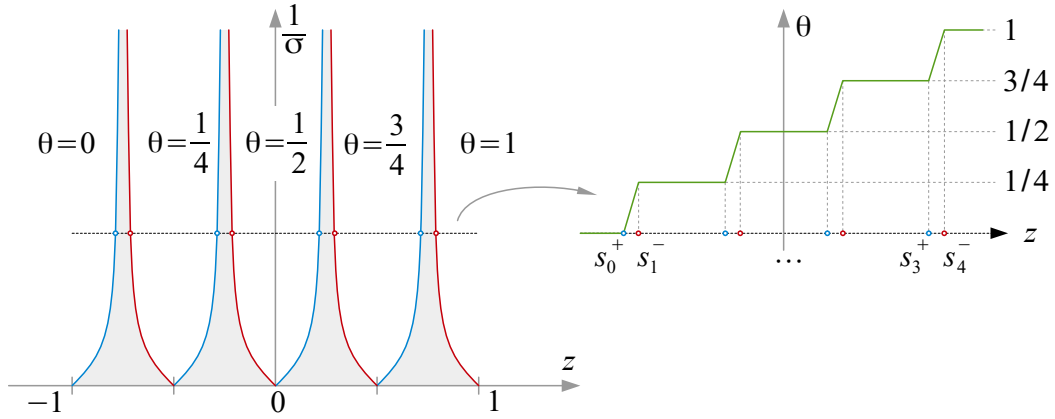

Figure 21: Representation of θ in the z - $\frac{1}{\sigma}$ plane for $M = 4$ (case $m_1 = 0$)

Note that in this case the limit differs from f but coincides with the minimum among $P^{M,n}(z) - 2m_M M^2 z^2$ (see Fig. 20), whose convexification still equals f^{**} .

In Fig. 21 we picture in the $z-\frac{1}{\sigma}$ -plane the zones where $\theta(z) = \theta_n$ for some $n \in \{0, \dots, M\}$ and those where $\theta(z)$ is affine for fixed σ (in grey).

5 Relaxation with exponential-kernel penalization

The case of concentrated kernels studied in the previous section allowed us to highlight some properties of $Q_{\mathbf{m}}f$, in particular we were able to characterize the locking states using explicit formulas. Now, we analyze the effect of the superposition of spatially distributed long-range interactions, which bring additional complexity to the structure of $Q_{\mathbf{m}}f$.

In Section 5.1 we sketch a method for obtaining bounds for a general kernel \mathbf{m} via higher-dimensional embeddings. This method is optimal in the case when the non-local term $\sum_{i,j} m_{|i-j|} (u_i - u_j)^2$ depending on the given kernel \mathbf{m} can be obtained by integrating out the variable v from the simplest additive energy depending on two variables u and v ; that is, $a \sum_i (v_i - v_{i-1})^2 + b \sum_i (u_i - v_i)^2$. To have this, we note that the kernel \mathbf{m} must be exponential. Hence, the study of general exponential kernels will constitute the main goal of this section. The idea of rewriting the problems defining $\widehat{Q}_{\mathbf{m}}f$ as additive problems in terms of an auxiliary variable has been already used implicitly in the case of concentrated kernels. Indeed, in that case we introduced coarse-grained energies depending only on M -neighbour interactions $u_{i+M} - u_i$ through the functions $P^{M,n}$.

5.1 Higher-dimensional embeddings for general \mathbf{m}

In this section we discuss the possibility of simplifying the quadratic penalty term in Definition 2.3 for an arbitrary kernel \mathbf{m} by introducing auxiliary variables. This will be later applied to the exponential kernel defined in (5.12). The idea is to view the long-range interactions parameterized by an arbitrary \mathbf{m} as a projection of short-range interactions operating in a higher-dimensional space. In other words, we now suppose that the kernels \mathbf{m} can be viewed as the Green's functions of some higher-dimensional local problems. Note however that the locality of the corresponding higher-dimensional problem can be expected only for kernels \mathbf{m} with sufficiently fast rate of decay. To highlight the ideas, we discuss in detail only the simplest class of projections, where the dimension of the extended configurational space is doubled. As a result, the nonlocal *scalar* problem is transformed into a local *vector* problem.

For each fixed $k \in \mathbb{N}$, we define a quadratic form depending on two variables as follows. Let A be a $(k+1) \times (k+1)$ matrix and let $s \in \mathbb{R}$ be a scalar parameter. We set

$$H^k[A, s](u, v) = 2s \langle Av, v \rangle + 2s \langle u - v, u - v \rangle, \quad (5.1)$$

where $u, v: \{0, \dots, k\} \rightarrow \mathbb{Z}$ and $\langle \cdot, \cdot \rangle$ denotes the scalar product in \mathbb{R}^{k+1} .

The following result restates the definition of $\widehat{Q}_{\mathbf{m}}f$ as a minimum problem involving a quadratic form of type (5.1).

Theorem 5.1 (higher-dimensional equivalent formulation). *Let \mathbf{m} satisfy (2.4) and be such that the function $n \mapsto m_n$ is not increasing for n large enough. Then, there exist a $(k+1) \times (k+1)$ -dimensional matrix $A_{\mathbf{m}}^k$ and a scalar $s_{\mathbf{m}}$ such that, setting $H_{\mathbf{m}}^k = H^k[A_{\mathbf{m}}^k, s_{\mathbf{m}}]$ in (5.1), the following equality holds*

$$\widehat{Q}_{\mathbf{m}}f(z) = \lim_{k \rightarrow +\infty} \frac{1}{k} \min \left\{ \sum_{i=1}^k f(u_i - u_{i-1}) + H_{\mathbf{m}}^k(u, v) : u, v \in \mathcal{A}(k, z) \right\} \quad (5.2)$$

for all $f: \mathbb{R} \rightarrow [0, +\infty)$ satisfying growth conditions (2.5) and (2.6).

The proof of Theorem 5.1 is based on Lemma 5.2 which implies that asymptotically the quadratic part of the energies in the definition of $\widehat{Q}_{\mathbf{m}}f$ can be viewed as projections of functions of the form (5.1).

To shorten the notation, we introduce the quadratic function

$$J_{\mathbf{m}}^k(u) = \sum_{i,j=0}^k m_{|i-j|} (u_i - u_j)^2, \quad (5.3)$$

defined on $u: \{0, \dots, k\} \rightarrow \mathbb{Z}$.

To quantify the relation between $J_{\mathbf{m}}^k$ and the corresponding $H_{\mathbf{m}}^k$, we introduce a notion of L^2 norm for $u: \{0, \dots, k\} \rightarrow \mathbb{Z}$ by setting

$$\|u\|_k^2 = \frac{1}{k} \sum_{i=1}^k (u_i)^2,$$

which coincides with the L^2 norm of the piecewise-constant function $\tilde{u}: (0, 1) \rightarrow \mathbb{R}$ defined by $\tilde{u}(t) = u_i$ in $(\frac{i-1}{k}, \frac{i}{k}]$.

Lemma 5.2 (projection of the quadratic part of the energies). *Let \mathbf{m} satisfy (2.4) and be such that the function $n \mapsto m_n$ is not increasing for n large enough. Let $J_{\mathbf{m}}^k$ be as in (5.3). Then, there exist a $(k+1) \times (k+1)$ -dimensional matrix $A_{\mathbf{m}}^k$ and a scalar $s_{\mathbf{m}}$ such that*

$$\min \{ H_{\mathbf{m}}^k(u, v) : v: \{0, \dots, k\} \rightarrow \mathbb{R} \} = J_{\mathbf{m}}^k(u) + \|u\|_k^2 o\left(\frac{1}{k}\right) \quad (5.4)$$

for all $u: \{0, \dots, k\} \rightarrow \mathbb{R}$, where $H_{\mathbf{m}}^k$ is defined in Theorem 5.1.

Proof. We introduce the $(k+1) \times (k+1)$ matrix $M_{\mathbf{m}}^k = (m_{ij})$ given by $m_{ij} = m_{|i-j|}$, $i, j = 0, \dots, k$. Note that the functional $J_{\mathbf{m}}^k$ is independent of the choice of m_0 , so that we can choose the value of m_0 arbitrarily. We assume that this value is such that the matrix $M_{\mathbf{m}}^k$ is invertible.

As a first step, we write the functional $J_{\mathbf{m}}^k$, up to an infinitesimal term, as the sum of a suitable quadratic form depending on the whole series of m_n and a residual boundary term. By Lemma A.1 (see Appendix A), up to a change of variables with $L = 1$ and $\varepsilon = 1/k$, we can suppose that u is constant in $[0, k^\alpha]$ and in $[k - k^\alpha, k]$ with a fixed $\alpha \in (\frac{3}{\beta}, 1)$, where β is the decay parameter of \mathbf{m} given by (2.4). Up to translations, we can assume $u_0 = 0$ and hence $u_i = 0$ for $i \leq k^\alpha$. Setting

$$s_{\mathbf{m}} = m_0 + 2 \sum_{n=1}^{+\infty} m_n \quad \text{and} \quad s_{\mathbf{m}}^i = \sum_{j=0}^k m_{ij},$$

we get

$$s_{\mathbf{m}}^i - s_{\mathbf{m}} = - \sum_{n=i+1}^{+\infty} m_n - \sum_{n=k-i+1}^{+\infty} m_n,$$

so that, using the decay condition $m_n = o(n^{-\beta})$, we obtain

$$\begin{aligned} J_{\mathbf{m}}^k(u) &= 2s_{\mathbf{m}} \langle u - \frac{1}{s_{\mathbf{m}}} M_{\mathbf{m}}^k u, u \rangle + 2 \sum_{i=0}^k (s_{\mathbf{m}}^i - s_{\mathbf{m}}) (u_i)^2 \\ &= 2s_{\mathbf{m}} \langle u - \frac{1}{s_{\mathbf{m}}} M_{\mathbf{m}}^k u, u \rangle - 2t_{\mathbf{m}} (u_k)^2 + \sum_{i=0}^k (u_i)^2 o(k^{1-\alpha\beta}) \\ &= 2s_{\mathbf{m}} \langle u - \frac{1}{s_{\mathbf{m}}} M_{\mathbf{m}}^k u, u \rangle - 2t_{\mathbf{m}} (u_k)^2 + \|u\|_k^2 o(k^{2-\alpha\beta}), \end{aligned}$$

where $t_{\mathbf{m}} = \sum_{n=0}^{+\infty} n m_n$. Note that $2 - \alpha\beta < -1$ since $\alpha > \frac{3}{\beta}$.

The matrix $A_{\mathbf{m}}^k$ will be obtained by modifying the matrix $s_{\mathbf{m}}(M_{\mathbf{m}}^k)^{-1} - I$, which gives a minimum for $H_{\mathbf{m}}^k$ in $v = \frac{1}{s_{\mathbf{m}}} M_{\mathbf{m}}^k u$, so as to take into account the boundary contribution. This is done by changing the values $(A_{\mathbf{m}}^k)_{11}$ and $(A_{\mathbf{m}}^k)_{kk}$ in such a way that they compensate the boundary terms. We set

$$A_{\mathbf{m}}^k = s_{\mathbf{m}} \begin{pmatrix} c_{\mathbf{m}} & 0 & \dots & \dots & 0 \\ 0 & 1 & 0 & \dots & \dots \\ \dots & \dots & \dots & \dots & \dots \\ \dots & \dots & 0 & 1 & 0 \\ \dots & \dots & 0 & 0 & c_{\mathbf{m}} \end{pmatrix} (M_{\mathbf{m}}^k)^{-1} - I, \quad \text{with} \quad c_{\mathbf{m}} = \frac{s_{\mathbf{m}} + m_0}{2t_{\mathbf{m}} + s_{\mathbf{m}} + m_0}. \quad (5.5)$$

We can write

$$A_{\mathbf{m}}^k = s_{\mathbf{m}}(M_{\mathbf{m}}^k)^{-1} - I - \frac{2t_{\mathbf{m}}s_{\mathbf{m}}}{2t_{\mathbf{m}} + s_{\mathbf{m}} + m_0} (e_0 \otimes e_0 + e_k \otimes e_k) (M_{\mathbf{m}}^k)^{-1},$$

and we prove that the minimum of $H_{\mathbf{m}}^k(u, v)$ coincides, up to an infinitesimal term, with $J_{\mathbf{m}}^k(u)$. This minimum is attained for $v^{k, \min}$ given by

$$v^{k, \min} = (A_{\mathbf{m}}^k + I)^{-1}u = \frac{1}{s_{\mathbf{m}}}M_{\mathbf{m}}^k u + \frac{2t_{\mathbf{m}}}{s_{\mathbf{m}}(s_{\mathbf{m}} + m_0)}u_k \begin{pmatrix} m_k \\ m_{k-1} \\ \dots \\ m_0 \end{pmatrix}. \quad (5.6)$$

Then, recalling the decay assumption on m_n , we get

$$\begin{aligned} H_{\mathbf{m}}^k(u, v^{k, \min}) &= 2s_{\mathbf{m}}\langle u - v^{k, \min}, u \rangle \\ &= 2s_{\mathbf{m}}\langle u - \frac{1}{s_{\mathbf{m}}}M_{\mathbf{m}}^k u, u \rangle - 2(u_k)^2 t_{\mathbf{m}} + |u_k| \sqrt{k} \|u\|_k o(k^{-\alpha\beta}) \\ &= 2s_{\mathbf{m}}\langle u - \frac{1}{s_{\mathbf{m}}}M_{\mathbf{m}}^k u, u \rangle - 2(u_k)^2 t_{\mathbf{m}} + \|u\|_k^2 o(k^{\frac{1}{2}-\alpha\beta}), \end{aligned} \quad (5.7)$$

concluding the proof of (5.4) since $\alpha > \frac{3}{\beta}$. \square

Remark 5.3. Let u^k be constant on $[0, k^\alpha]$ and $[k - k^\alpha, k]$. Then the corresponding $v^{k, \min}$ given by (5.6) satisfies $|v_0^{k, \min} - u_0^k| + |v_k^{k, \min} - u_k^k| = o(k^{\frac{1}{2}-\alpha\beta})\|u^k\|_k$. Hence it can be modified so as to obtain \widehat{v}^k equal to u^k in 0 and k and $|v_i^{k, \min} - v_i^k| = o(k^{\frac{1}{2}-\alpha\beta})\|u^k\|_k$ for all i . By (5.7) we can estimate

$$H_{\mathbf{m}}^k(u, \widehat{v}^k) \leq H_{\mathbf{m}}^k(u, v^{k, \min}) + \|u^k\|_k^2 o(k^{1-\alpha\beta}).$$

If $\|u^k\|_k$ are equibounded, then the last term is $o(\frac{1}{k})$ since $\alpha > \frac{3}{\beta}$. Note that we may also construct \widehat{v}^k so that $\widehat{v}_i^k = u_0^k$ for $i \leq k^{\alpha'}$ and $\widehat{v}_i^k = u_k^k$ if $i \geq k - k^{\alpha'}$ with $\alpha' < \alpha$.

Proof of Theorem 5.1. We write

$$\widehat{Q}_{\mathbf{m}} f(z) = \lim_{k \rightarrow +\infty} \frac{1}{k} \min \left\{ \sum_{i=1}^k f(u_i - u_{i-1}) + J_{\mathbf{m}}^k(u) : u \in \mathcal{A}(k, z) \right\}. \quad (5.8)$$

Let u^k denote a minimizer of the problem above, and note that $\|u^k\|_k$ are equibounded in view of the growth condition on $f(z) + m_1 z^2$. Note that thanks to Lemma A.1 we may suppose that the function u^k is constant on $[0, k^\alpha]$ and $[k - k^\alpha, k]$. Then, applying Lemma 5.2 and Remark 5.3, we obtain the desired result. \square

In general, the advantage of the rewriting in Theorem 5.1 is not clear. However, thanks to the two-variable formulation, we can obtain some general lower bound in suitable hypotheses. In the next section, we will see that for exponential kernels functionals $H_{\mathbf{m}}^k$ can be rewritten as nearest-neighbour energies, which will allow to make these bounds sharp.

Remark 5.4 (lower bounds with additive vector energies). Suppose that there exists $C > 0$ such that for all $v \in \mathcal{A}(k; z)$

$$\langle A_{\mathbf{m}}^k v, v \rangle \geq C \sum_{i=1}^k (v_i - v_{i-1})^2 + \|v\|_k^2 o(1)_{k \rightarrow +\infty}. \quad (5.9)$$

Then, by (5.2), we can bound $\widehat{Q}_{\mathbf{m}} f(z)$ from below with limits of scaled minimum problems for energies of the form

$$\sum_{i=1}^k f(u_i - u_{i-1}) + 2s_{\mathbf{m}} C \sum_{i=1}^k (v_i - v_{i-1})^2 + 2s_{\mathbf{m}} \sum_{i=1}^k (u_i - v_i)^2.$$

We will see in the next section that this holds with some particular choices of the kernel \mathbf{m} ; namely, the exponential kernels.

In view of Remark 5.4, we now focus on bounds for problems involving energies of the form

$$E(u, v; [0, k]) = \sum_{i=1}^k f(u_i - u_{i-1}) + a \sum_{i=1}^k (v_i - v_{i-1})^2 + b \sum_{i=1}^k (u_i - v_i)^2$$

with $a, b > 0$.

We suppose that there exist z^* and η such that f is convex for $z \leq z^*$ and $f(z) \geq \eta$ for $z > z^*$. For any $N \geq 1$ we define

$$g_N(z) = \frac{1}{N} \left(\min \left\{ \sum_{i=2}^N f(u_i - u_{i-1}) + a \sum_{i=1}^N (v_i - v_{i-1})^2 + b \sum_{i=1}^N (u_i - v_i)^2 \right. \right. \\ \left. \left. v_0 = 0, v_N = Nz, u_i - u_{i-1} \leq z^* \text{ for } i \geq 2 \right\} + \eta \right), \quad (5.10)$$

where we limit the interactions $v_i - v_j$ only to nearest neighbours, and we allow $u_i - u_{i-1} > z^*$ only for $i = 1$. Note that if $N = 1$ then $g_1(z) = az^2 + \eta$.

We also set $g_\infty(z) = f(z) + az^2$ with domain $z \leq z^*$, which corresponds to minimal states with $u_i - u_{i-1} \leq z^*$ for all i .

Proposition 5.5 (lower bound with nearest-neighbour energies). *We have*

$$\lim_{k \rightarrow +\infty} \frac{1}{k} \min \left\{ E(u, v; [0, k]) : u_k - u_0 = v_k - v_0 = kz \right\} \geq \left(\inf_N g_N(z) \right)^{**}. \quad (5.11)$$

Proof. The proof is obtained giving a lower bound for the minima

$$\frac{1}{k} \min \left\{ \sum_{i=1}^k f_\eta(u_i - u_{i-1}) + a \sum_{i=1}^k (v_i - v_{i-1})^2 + b \sum_{i=1}^k (u_i - v_i)^2 : u_k - u_0 = v_k - v_0 = kz \right\},$$

where

$$f_\eta(z) = \begin{cases} f(z) & \text{if } z \leq z^* \\ \eta & \text{if } z > z^*. \end{cases}$$

Consider a minimizer u for such problem. If $u_i - u_{i-1} \leq z^*$ for all i then by the convexity of f this minimum equals the value $g_0(z)$. If otherwise $u_i - u_{i-1} > z^*$ for some i , note that we can always suppose that this holds for $i = 1$, by splitting the discrete interval $\{0, \dots, k\}$ into subsets $\{i_{k_{j-1}}, \dots, i_{k_j}\}$, $j = 1, \dots, r$, in which $u_i - u_{i-1} > z^*$ only for $i = i_{k_{j-1}} + 1$, we obtain a lower estimate with

$$\sum_{j=1}^r \frac{N_j}{k} g_{N_j}(z_j)$$

where $N_j = k_j - k_{j-1}$ and $z_j = \frac{u_{k_j} - u_{k_{j-1}}}{N_j}$, so that we have the convex combination

$$\sum_{j=1}^r \frac{N_j}{k} z_j = z.$$

From this estimate (5.11) follows. □

We will prove general properties of the functions g_N in Section 5.3, which will allow to describe the structure of their convex envelope and their optimality in computing $\widehat{Q}_{\mathbf{m}}f$.

5.2 Reduction to a local problem for the exponential kernel

We now introduce some notation for the exponential kernels. We define

$$\mathbf{m} = \mathbf{m}^\sigma = \{m_n^\sigma\} = \{e^{-\sigma n}\}, \quad (5.12)$$

where $\sigma > 0$ is a given constant. Highlighting the dependence on the parameter σ , we set

$$\widehat{Q}_\sigma f(z) = \lim_{k \rightarrow +\infty} \frac{1}{k} \inf \left\{ \sum_{i=1}^k f(u_i - u_{i-1}) + \sum_{i,j=0}^k e^{-|i-j|\sigma} (u_i - u_j)^2 : u \in \mathcal{A}(k; z) \right\}, \quad (5.13)$$

and introduce the corresponding \mathbf{m}^σ -transform of f

$$Q_\sigma f(z) = \widehat{Q}_\sigma f(z) - a_{\mathbf{m}^\sigma} z^2 = \widehat{Q}_\sigma f(z) - \frac{2e^{-\sigma}(1 + e^{-\sigma})}{(1 - e^{-\sigma})^3} z^2. \quad (5.14)$$

Let F_ε^σ denote the non-local functionals

$$F_\varepsilon^\sigma(u; I) = \varepsilon \sum_{i \in \mathcal{I}_\varepsilon^*(I)} f\left(\frac{u_i - u_{i-1}}{\varepsilon}\right) + \varepsilon \sum_{i,j \in \mathcal{I}_\varepsilon(I)} e^{-\sigma|i-j|} \left(\frac{u_i - u_j}{\varepsilon}\right)^2, \quad (5.15)$$

with exponential kernel $m_n = e^{-\sigma n}$, where $\mathcal{I}_\varepsilon(I) = \{i \in \mathbb{Z} : \varepsilon i \in I\}$, $\mathcal{I}_\varepsilon^*(I) = \{i \in \mathbb{Z} : \varepsilon i, \varepsilon(i-1) \in I\}$ and the function u belongs to $\mathcal{A}_\varepsilon(I) = \{u : \varepsilon \mathcal{I}_\varepsilon(I) \rightarrow \mathbb{R}\}$ as defined in (2.2). Following the general approach formulated in Section 5.1, given $a, b > 0$ we define the local two-variable energies

$$E_\varepsilon(u, v; I) = \varepsilon \sum_{i \in \mathcal{I}_\varepsilon^*(I)} f\left(\frac{u_i - u_{i-1}}{\varepsilon}\right) + \frac{a}{\varepsilon} \sum_{i \in \mathcal{I}_\varepsilon^*(I)} (v_i - v_{i-1})^2 + \frac{b}{\varepsilon} \sum_{i \in \mathcal{I}_\varepsilon^*(I)} (u_i - v_i)^2 \quad (5.16)$$

for $u, v \in \mathcal{A}_\varepsilon(I)$. We will prove an asymptotic equivalence result between F_ε^σ and E_ε ; more precisely, that the Γ -limits of the two sequences are the same for a suitable choice of $a = a_\sigma$ and $b = b_\sigma$. The Γ -limit of E_ε is computed with respect to the convergence $u^\varepsilon, v^\varepsilon \rightarrow u$ defined as the convergence in $L^2(I)$ of the piecewise-constant extensions of u^ε and v^ε to the function $u \in H^1(I)$. The result is obtained, in the spirit of Section 5.1, by explicitly integrating out the variable v .

Theorem 5.6 (asymptotic equivalence). *Let*

$$a_\sigma = a_{\mathbf{m}^\sigma} = \frac{2(1 + e^{-\sigma})e^{-\sigma}}{(1 - e^{-\sigma})^3}, \quad b_\sigma = \frac{2(1 + e^{-\sigma})}{(1 - e^{-\sigma})}, \quad (5.17)$$

and set $E_\varepsilon^\sigma = E_\varepsilon$ as defined in (5.16) with $a = a_\sigma$ and $b = b_\sigma$. Then the sequence E_ε^σ Γ -converges to the same Γ -limit as the sequence F_ε^σ .

Remark 5.7 (asymptotic behaviour controlled by σ). We can interpret the extremal regimes of strong and weak additivity in terms of the parameters of the two-parameter energies (5.16). Let a_σ, b_σ be given by (5.17). As $\sigma \rightarrow 0$ we have both $a_\sigma \rightarrow +\infty$ and $b_\sigma \rightarrow +\infty$, with an increasing strength of the effect of the term involving the distance of u from the affine function zi . Conversely, when $\sigma \rightarrow +\infty$ we have $a_\sigma \rightarrow 0$, and the role of this distance term gradually diminishes.

Remark 5.8 (equivalence with arbitrary coefficients). The equivalence result in Theorem 5.6 can be extended to arbitrary pairs $a, b > 0$ up to considering the non-local functionals with kernel $m_n = \varrho e^{-\sigma n}$; that is, the functionals given by

$$F_\varepsilon^{\varrho, \sigma}(u; I) = \varepsilon \sum_{i, i-1 \in \mathcal{I}_\varepsilon(I)} f\left(\frac{u_i - u_{i-1}}{\varepsilon}\right) + \varepsilon \varrho \sum_{i, j \in \mathcal{I}_\varepsilon(I)} e^{-\sigma|i-j|} \left(\frac{u_i - u_j}{\varepsilon}\right)^2,$$

with the choices

$$\sigma = \sigma_{a,b} = 2 \sinh^{-1} \left(\frac{1}{2} \sqrt{\frac{b}{a}} \right) \quad \text{and} \quad \varrho = \varrho_{a,b} = \frac{b^2}{4a \sinh(\sigma_{a,b})}. \quad (5.18)$$

Indeed, with this definition we get

$$\frac{a}{\varrho_{a,b}} = \frac{2(1 + e^{-\sigma_{a,b}})e^{-\sigma_{a,b}}}{(1 - e^{-\sigma_{a,b}})^3} = a_\sigma \quad \text{and} \quad \frac{b}{\varrho_{a,b}} = \frac{2(1 + e^{-\sigma_{a,b}})}{1 - e^{-\sigma_{a,b}}} = b_\sigma,$$

so that we can apply Theorem 5.6 obtaining the equivalence between $\frac{1}{\varrho}F_\varepsilon^{\varrho,\sigma}$ and $\frac{1}{\varrho}E_\varepsilon^\sigma$. The corresponding (trivial) generalization of $Q_\sigma f$ in (5.14) can be obtained by defining

$$\widehat{Q}_{\sigma,\varrho}f(z) = \lim_{k \rightarrow +\infty} \frac{1}{k} \inf \left\{ \sum_{i=1}^k f(u_i - u_{i-1}) + \varrho \sum_{i,j=0}^k e^{-|i-j|\sigma} (u_i - u_j)^2 : u \in \mathcal{A}(k; z) \right\}, \quad (5.19)$$

and setting $Q_{\sigma,\varrho}f(z) = \widehat{Q}_{\sigma,\varrho}f(z) - a_\sigma \varrho z^2$, with a_σ as in (5.17).

The proof of Theorem 5.6 is based on the following lemma, which allows to integrate out the variable v by applying the general result of Lemma 5.2 to the case of exponential kernels.

Lemma 5.9. *Let $L > 0$ and $k_\varepsilon = \lfloor \frac{L}{\varepsilon} \rfloor$. We fix $\alpha \in (0, 1)$ and set $n_\varepsilon = \lfloor (k_\varepsilon)^\alpha \rfloor$. Let F_ε^σ be given by (5.15) and E_ε^σ be given by (5.16) with a_σ, b_σ as in (5.17) and $I = [0, L]$. Then, if $u^\varepsilon \in \mathcal{A}_\varepsilon = \mathcal{A}_\varepsilon([0, L])$ satisfies $u_i^\varepsilon = u_0^\varepsilon$ for $i \leq n_\varepsilon$, $u_i^\varepsilon = u_{k_\varepsilon}^\varepsilon$ for $i \geq k_\varepsilon - n_\varepsilon$, we have*

$$\min\{E_\varepsilon^\sigma(u^\varepsilon, v; [0, L]) : v \in \mathcal{A}_\varepsilon^\#(u^\varepsilon)\} = F_\varepsilon^\sigma(u^\varepsilon; [0, L]) + \|u^\varepsilon\|_{L^2}^2 o(1)_{\varepsilon \rightarrow 0} \quad (5.20)$$

where $\mathcal{A}_\varepsilon^\#(u^\varepsilon) = \{v \in \mathcal{A}_\varepsilon : v_0 = v_1 = u_0^\varepsilon, v_{k_\varepsilon} = v_{k_\varepsilon-1} = u_{k_\varepsilon}^\varepsilon\}$.

Proof. For $u, v \in \mathcal{A}_\varepsilon$, we set

$$H_\varepsilon(u, v) = \frac{a_\sigma}{\varepsilon} \sum_{i=1}^{k_\varepsilon} (v_i - v_{i-1})^2 + \frac{b_\sigma}{\varepsilon} \sum_{i=1}^{k_\varepsilon} (u_i - v_i)^2 = E_\varepsilon^\sigma(u, v; [0, L]) - \varepsilon \sum_{i=1}^{k_\varepsilon} f(u_i - u_{i-1})$$

$$J_\varepsilon(u) = \frac{1}{\varepsilon} \sum_{i,j=0}^{k_\varepsilon} e^{-\sigma|i-j|} (u_i - u_j)^2 = F_\varepsilon^\sigma(u, v; [0, L]) - \varepsilon \sum_{i=1}^{k_\varepsilon} f(u_i - u_{i-1}).$$

Up to translations, we can assume $u_0^\varepsilon = 0$ (and hence $u_i^\varepsilon = 0$ for $i \leq L\varepsilon^{-\alpha}$). We introduce the $(k_\varepsilon + 1) \times (k_\varepsilon + 1)$ matrix $M_\sigma^\varepsilon = (m_{ij})$ given by $m_{ij} = m_{|i-j|}^\sigma = e^{-\sigma|i-j|}$, $i, j = 0, \dots, k_\varepsilon$. Note that $m_n^\sigma = e^{-\sigma n}$ satisfies $m_n^\sigma = o(n^{-\beta})$ for any β and in particular for $\beta > \frac{3}{\alpha}$. In order to apply Lemma 5.2, we compute $s_\sigma = s_{\mathbf{m}^\sigma}$ and the matrix $A_\sigma^\varepsilon = A_{\mathbf{m}^\sigma}^\varepsilon$ given by formula (5.5), obtaining

$$s_\sigma = m_0^\sigma + 2 \sum_{n=1}^{+\infty} m_n^\sigma = \frac{1 + e^{-\sigma}}{1 - e^{-\sigma}} \quad \text{and} \quad A_\sigma^\varepsilon = D_\sigma^\varepsilon (M_\sigma^\varepsilon)^{-1} - I, \quad (5.21)$$

where D_σ^ε is the $(k_\varepsilon + 1) \times (k_\varepsilon + 1)$ diagonal matrix with diagonal $\{1 + e^{-\sigma}, s_\sigma, \dots, s_\sigma, 1 + e^{-\sigma}\}$. Moreover, in this case we can compute the inverse of the matrix M_σ^ε , which is the tridiagonal $(k_\varepsilon + 1) \times (k_\varepsilon + 1)$ matrix given by

$$(M_\sigma^\varepsilon)^{-1} = \frac{1}{1 - e^{-2\sigma}} \begin{pmatrix} 1 & -e^{-\sigma} & 0 & \dots & 0 \\ -e^{-\sigma} & 1 + e^{-2\sigma} & -e^{-\sigma} & \dots & 0 \\ 0 & -e^{-\sigma} & 1 + e^{-2\sigma} & -e^{-\sigma} & \dots \\ \dots & \dots & \dots & \dots & \dots \\ 0 & \dots & \dots & 0 & -e^{-\sigma} & 1 \end{pmatrix}. \quad (5.22)$$

Now, to each $u \in \mathcal{A}_\varepsilon$ we associate the corresponding function defined on $\{0, \dots, k_\varepsilon\}$ by $i \mapsto u(\varepsilon i)$; with a slight abuse of notation, we still denote this function by u . Setting

$$H_\sigma^{k_\varepsilon}(u, v) = \frac{2s_\sigma}{\varepsilon} \langle A_\sigma^\varepsilon v, v \rangle + \frac{2s_\sigma}{\varepsilon} \langle u - v, u - v \rangle$$

for $u, v: \{0, \dots, k_\varepsilon\} \rightarrow \mathbb{R}$, we can then apply Lemma 5.2 with $k = k_\varepsilon$, obtaining

$$\min\{H_\sigma^{k_\varepsilon}(u^\varepsilon, v) : v: \{0, \dots, k_\varepsilon\} \rightarrow \mathbb{R}\} = J_\varepsilon(u^\varepsilon) + \|u^\varepsilon\|_{L^2}^2 o(1)_{\varepsilon \rightarrow 0}. \quad (5.23)$$

We conclude by proving that, up to an infinitesimal term, the minimum of $H_\sigma^{k_\varepsilon}(\tilde{u}^\varepsilon, \cdot)$ on \mathcal{A}_ε coincides with the minimum of $H_\varepsilon(u^\varepsilon, \cdot)$ on $\mathcal{A}_\varepsilon^\#$. Indeed, given $u, v \in \mathcal{A}_\varepsilon$ we can write

$$\begin{aligned} H_\sigma^{k_\varepsilon}(u, v) &= -\frac{s_\sigma}{\varepsilon} \sum_{i,j=0}^{k_\varepsilon} (A_\sigma^\varepsilon)_{ij} (v_i - v_j)^2 + \frac{2s_\sigma}{\varepsilon} \sum_{i=0}^{k_\varepsilon} \left(\sum_{j=0}^{k_\varepsilon} (A_\sigma^\varepsilon)_{ij} \right) v_i^2 + \frac{2s_\sigma}{\varepsilon} \sum_{i=0}^{k_\varepsilon} (u_i - v_i)^2 \\ &= \frac{2(1 + e^{-\sigma})e^{-\sigma}}{\varepsilon(1 - e^{-\sigma})^3} \sum_{i=1}^{k_\varepsilon} (v_i - v_{i-1})^2 + \frac{2(1 + e^{-\sigma})}{\varepsilon(1 - e^{-\sigma})} \sum_{i=0}^{k_\varepsilon} (u_i - v_i)^2 \\ &= H_\varepsilon(u, v), \end{aligned} \quad (5.24)$$

since $\sum_{j=0}^{k_\varepsilon} (A_\sigma^\varepsilon)_{ij} = 0$ for any i by (5.21) and (5.22). This formula in particular implies

$$\langle A_\sigma^\varepsilon v, v \rangle = \frac{e^{-\sigma}}{(1 - e^{-\sigma})^2} \sum_{i=1}^{k_\varepsilon} (v_i - v_{i-1})^2;$$

that is, estimate (5.9) with $C = \frac{e^{-\sigma}}{(1 - e^{-\sigma})^2}$, which in this case is an equality.

Finally, recalling Remark 5.3 we obtain

$$\min\{H_\sigma^{k_\varepsilon}(u^\varepsilon, v) : v: \{0, \dots, k_\varepsilon\} \rightarrow \mathbb{R}\} = \min\{H_\varepsilon(u^\varepsilon, v) : v \in \mathcal{A}_\varepsilon^\#(u^\varepsilon)\} + \|u^\varepsilon\|_{L^2}^2 o(1)_{\varepsilon \rightarrow 0}$$

and the claim follows by (5.23). \square

Proof of Theorem 5.6. Upper estimate. Let $F^\sigma(u; [0, L])$ be the Γ -limit of the sequence F_ε^σ . Let $u \in L^2(0, L)$ be such that $F^\sigma(u; [0, L]) < +\infty$ and let $u^\varepsilon \in \mathcal{A}_\varepsilon$ be a recovery sequence for the Γ -limit $F^\sigma(u; [0, L])$. Let \hat{u}^ε be the sequence given by Lemma A.1 and $v^{\varepsilon, \min}$ be obtained by minimization of the minimum problem in (5.20) with $u^\varepsilon = \hat{u}^\varepsilon$. Recalling Lemma 5.9, we get

$$\begin{aligned} \limsup_{\varepsilon \rightarrow 0} E_\varepsilon^\sigma(\hat{u}^\varepsilon, v^{\varepsilon, \min}; [0, L]) &\leq \limsup_{\varepsilon \rightarrow 0} F_\varepsilon^\sigma(\hat{u}^\varepsilon, [0, L]) \\ &\leq \limsup_{\varepsilon \rightarrow 0} F_\varepsilon^\sigma(u^\varepsilon; [0, L]). \end{aligned}$$

This gives the upper estimate for the Γ -limit of E_ε^σ .

Lower estimate. Let $u \in H^1(0, L)$ and let $u^\varepsilon, v^\varepsilon$ converge to u in $L^2(0, L)$ and be such that $\sup E_\varepsilon^\sigma(u^\varepsilon, v^\varepsilon; [0, L]) \leq S < +\infty$. Let $\hat{u}^\varepsilon, \hat{v}^\varepsilon$ be the sequences given by Lemma A.1(B). Hence

$$\liminf_{\varepsilon \rightarrow 0} E_\varepsilon^\sigma(\hat{u}^\varepsilon, \hat{v}^\varepsilon; (0, L)) \leq \liminf_{\varepsilon \rightarrow 0} E_\varepsilon^\sigma(u^\varepsilon, v^\varepsilon; (0, L)). \quad (5.25)$$

Applying Lemma 5.9 we obtain

$$\begin{aligned} \liminf_{\varepsilon \rightarrow 0} E_\varepsilon^\sigma(u^\varepsilon, v^\varepsilon; [0, L]) &\geq \liminf_{\varepsilon \rightarrow 0} E_\varepsilon^\sigma(\hat{u}^\varepsilon, v^{\varepsilon, \min}(\hat{u}^\varepsilon); [0, L]) \\ &\geq \liminf_{\varepsilon \rightarrow 0} F_\varepsilon^\sigma(\hat{u}^\varepsilon; [0, L]). \end{aligned}$$

This concludes the proof. \square

By the results in Section 5.1 we can use the equivalence above to give a useful characterization of $\widehat{Q}_\sigma f$.

Remark 5.10 (representation of $\widehat{Q}_\sigma f$ in terms of local functionals). Formula (5.2) in Theorem 5.1 and equality (5.24) prove the following formula for the function $\widehat{Q}_\sigma f$ defined in (5.13):

$$\widehat{Q}_\sigma f(z) = \lim_{N \rightarrow +\infty} \frac{1}{N} \min\{E_1^\sigma(u, v; [0, N]) : u_0 = v_0 = 0, u_N = v_N = Nz\}, \quad (5.26)$$

where E_1^σ is defined by (5.16) with $\varepsilon = 1$ and $a = a_\sigma, b = b_\sigma$ satisfying (5.17).

Remark 5.11 (representation of the constrained relaxation in terms of local functionals). Formula (5.26) can be extended to constrained problems; namely, we have

$$\widehat{Q}_\sigma f\left(\frac{p}{q}, z\right) = \liminf_{k \rightarrow +\infty} \frac{1}{kq} \min\left\{E_1^\sigma(u, v; [0, kq]) : u, v \in \mathcal{A}(kq; z), u \in \mathcal{V}\left(kq; \frac{p}{q}\right)\right\}, \quad (5.27)$$

where, accordingly with the notation above, $\widehat{Q}_\sigma f(\theta, z)$ denotes the constrained relaxation $\widehat{Q}_{\mathbf{m}\sigma} f(\theta, z)$, and $\mathcal{V}(kq; \frac{p}{q})$ is the set of admissible constrained functions defined in (3.2). Indeed, we note that Theorem 5.1 also holds for constrained relaxation, since we can apply Lemma 5.2 to u satisfying a volume constraint (see Lemma 3.3).

Remark 5.12 (non-exponential kernels). For a general kernel \mathbf{m} the matrix $M^k = (m_{ij})_{i,j=0}^k$ is a symmetric *Toeplitz matrix*. Under decay conditions on m_n we can apply the arguments in Section 5.1. However, since $(M^k)^{-1}$ now is not of the form (5.22) (for some insight on the problem of the inversion of a general symmetric Toeplitz matrix we refer, e.g., to [18]), the resulting functional H_ε^k does not depend on nearest neighbours only and the argument showing the optimality of the bounds can not be completed as above. However, for particular classes of kernels \mathbf{m} the resulting functionals H_ε^k may be still amenable to analysis, even if they involve next-to-nearest-neighbour interactions and beyond. The analytical transparency of such functionals will then allow one to extract useful information on the form of the corresponding $\widehat{Q}_\mathbf{m}f$.

5.3 Truncated convex potential

In this section we show some properties of $\widehat{Q}_\sigma f$ and of the corresponding phase function θ if f is a general truncated convex function; that is,

$$f(z) = \begin{cases} \tilde{f}(z) & \text{if } z \leq z^* \\ \tilde{f}(z^*) & \text{if } z > z^*, \end{cases} \quad (5.28)$$

where $z^* > 0$ and $\tilde{f}: \mathbb{R} \rightarrow [0, +\infty)$ is strictly convex and such that $\tilde{f}(0) = 0$. Note that we can suppose that \tilde{f} satisfies the growth condition

$$\tilde{f}(z) \geq c_1 z^2 - c_2$$

in $[0, +\infty)$ for some $c_1, c_2 > 0$. Using the notation of Section 3, we set $A = [z^*, +\infty)$.

Remark 5.13 (more general f). Note that the condition $\tilde{f}(0) = 0$ can be substituted by the hypothesis that \tilde{f} has a minimum point $z_{\min} < z^*$, since affine changes of variables are compatible with the definition of $\widehat{Q}_\mathbf{m}f$ by Remark 2.25.

5.3.1 Characterization of $\widehat{Q}_\sigma f$ in terms of periodic arrangements

Given the local form of the problem (5.26) formulated in terms of the two-variable functional $E_1^\sigma(u, v; [0, N])$, the relaxed energy $\widehat{Q}_\sigma f$ can be obtained by optimizing the location of ‘broken bonds’; that is, of indices i such that $u_i - u_{i-1} \in A$, similarly to what done in the case of concentrated kernels. The fact that these bonds can be always considered as either isolated or organized in a ‘broken island’ makes the structure of oscillations (microstructure) compatible with the lattice. This makes the problem analytically tractable.

Note first that on the complement of the broken bonds the energy coincides with its ‘convex part’, defined as follows. Given $a, b > 0$, for a bounded interval I and $u, v \in \mathcal{A}_\varepsilon(I)$ we

introduce the functional \tilde{E}_ε given by

$$\tilde{E}_\varepsilon(u, v; I) = \varepsilon \sum_{i \in \mathcal{I}_\varepsilon^*(I)} \tilde{f}\left(\frac{u_i - u_{i-1}}{\varepsilon}\right) + \frac{a}{\varepsilon} \sum_{i \in \mathcal{I}_\varepsilon^*(I)} (v_i - v_{i-1})^2 + \frac{b}{\varepsilon} \sum_{i \in \mathcal{I}_\varepsilon(I)} (u_i - v_i)^2, \quad (5.29)$$

where we recall that $\mathcal{I}_\varepsilon^* = \{i \in \mathbb{Z} : \varepsilon i, \varepsilon(i-1) \in I\}$. Note that, since these energies will be used to compute minimum problems with Dirichlet boundary conditions, we consider the last term of the sum in the whole $\mathcal{I}_\varepsilon(I) = \{i \in \mathbb{Z} : \varepsilon i \in I\}$.

In view of Section 5.1, for all $N \geq 2$ we can write the functions g_N introduced in (5.10) with η replaced by $\tilde{f}(z^*)$ as

$$g_N^{a,b}(z) = g_N(z) = \frac{1}{N} \left(\tilde{f}(z^*) + \min \{av_1^2 + \tilde{E}_1(u, v; [1, N]) : v_N = Nz\} \right). \quad (5.30)$$

They represent the minimal energy of an array of N bonds, of which the first one is broken, with given average gradient. By uniformity of notation, we also set

$$g_1(z) = \tilde{f}(z^*) + az^2 \quad \text{and} \quad g_\infty(z) = \tilde{f}(z) + az^2. \quad (5.31)$$

If $a = a_\sigma$ and $b = b_\sigma$ are given by (5.17), then we set

$$g_N^\sigma(z) = g_N(z) \quad \text{and} \quad \tilde{E}_\varepsilon^\sigma(u, v; I) = \tilde{E}_\varepsilon(u, v; I).$$

Note that, by using $u_i = v_i = zi$ as test function in the definition of $g_N^\sigma(z)$, we get

$$\lim_{N \rightarrow +\infty} g_N^\sigma(z) \leq \tilde{f}(z) + a_\sigma z^2.$$

In the following proposition, based on the analysis of the distribution of broken bonds in minimizers, we show that $\widehat{Q}_\sigma f(z)$, considered as the infimum of the corresponding constrained functions, can be described by only using the values $\theta = \frac{1}{N}$, which will be proved to be the locking states. The full description of this structure will be given in Proposition 5.23, after a delicate analysis of the general properties of g_N .

Proposition 5.14 (characterization of $\widehat{Q}_\sigma f$ in terms of periodic arrangements). *Fixed $\sigma > 0$, let $a = a_\sigma$ and $b = b_\sigma$ be given by (5.17). If f is a truncated convex potential as in (5.28), then*

$$\widehat{Q}_\sigma f(z) = \left(\inf_{N \in \mathbb{N}} \{g_N^\sigma\} \right)^{**}(z). \quad (5.32)$$

Remark 5.15. Note that, recalling Remark 5.8, Proposition 5.14 holds for any $a, b > 0$ with $g_N^{a,b}$ in place of g_N^σ and a in place of a_σ , up to substituting $\widehat{Q}_\sigma f$ with $\widehat{Q}_{\sigma_a, b, \varrho_{a,b}} f$ as defined in (5.19), with $\sigma_{a,b}$ and $\varrho_{a,b}$ given by (5.18).

Proof of Proposition 5.14. The lower bound is a consequence of Proposition 5.5. To conclude the proof we show that $\widehat{Q}_\sigma f(z) \leq (\inf_{n \in \mathbb{N}} \{g_n^\sigma\})^{**}(z)$. Since $\widehat{Q}_\sigma f$ is convex, it is sufficient to prove that $\widehat{Q}_\sigma f(z) \leq \inf_{n \in \mathbb{N}} \{g_n^\sigma(z)\}$.

We fix $\delta > 0$. For $z \in \mathbb{R}$ there exists $\bar{n} \in \mathbb{N}$ such that $g_{\bar{n}}^\sigma(z) \leq \inf_{n \in \mathbb{N}} \{g_n^\sigma(z)\} + \delta$. If $\bar{n} = 1$, then we can take as test functions u, v given by $u_i = v_i = iz$. For any $N \geq 1$ we get

$$\frac{1}{N} E_1^\sigma(u, v; [0, N]) \leq \frac{1}{N} \tilde{E}_1^\sigma(u, v; [0, N]) = \tilde{f}(z) + a_\sigma z^2 = g_1^\sigma(z)$$

and the result follows by taking the limit for $N \rightarrow +\infty$. Otherwise, let $\bar{u}, \bar{v} \in \mathcal{A}_1([1, \bar{n}])$ be such that $\bar{v}_{\bar{n}} = \bar{n}z$ and

$$\tilde{f}(z^*) + a_\sigma \bar{v}_1^2 + \tilde{E}_1^\sigma(\bar{u}, \bar{v}; [1, \bar{n}]) = \bar{n} g_{\bar{n}}^\sigma(z).$$

We extend \bar{u} and \bar{v} in 0 by setting $\bar{u}_0 = \bar{n}z - \bar{u}_{\bar{n}}$ and $\bar{v}_0 = 0$. It follows that

$$\begin{aligned} E_1^\sigma(\bar{u}, \bar{v}; [0, \bar{n}]) &\leq E_1^\sigma(\bar{u}, \bar{v}; [1, \bar{n}]) + b_\sigma(\bar{u}_1 - \bar{v}_1)^2 + a_\sigma \bar{v}_1^2 + \tilde{f}(z^*) \\ &\leq \tilde{E}_1^\sigma(\bar{u}, \bar{v}; [1, \bar{n}]) + a_\sigma \bar{\lambda}^2 + \tilde{f}(z^*) \\ &= \bar{n} g_{\bar{n}}^\sigma(z). \end{aligned}$$

For any $N \geq 1$ we choose u^N and v^N as test functions in $[0, \bar{n}N]$ defined by setting u_i^N equal to $(j-1)\bar{n}z + \bar{u}_{i-(j-1)\bar{n}}$ in each $[(j-1)\bar{n}, j\bar{n}]$, $j \in \{1, \dots, N-1\}$ and in $[(N-1)\bar{n}, N\bar{n}]$ and correspondingly v_i^N . We get

$$\frac{1}{\bar{n}N} E_1^\sigma(u^N, v^N; [0, \bar{n}N]) = \frac{1}{\bar{n}N} N E_1^\sigma(\bar{u}, \bar{v}; [0, \bar{n}]) \leq g_{\bar{n}}^\sigma(z) \leq \inf_{n \in \mathbb{N}} \{g_n^\sigma(z)\} + \delta.$$

Letting $N \rightarrow +\infty$ the claim follows by the representation formula for $\widehat{Q}_\sigma f$ given in (5.26). \square

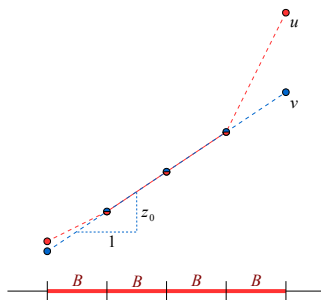

Figure 22: Shape of a minimizer of (5.33) in a ‘broken island’.

Remark 5.16 (simplification of the minimal configurations). Given $u \in \mathcal{A}_1([0, N])$, we say that $i \in \{1, \dots, N\}$ belongs to $\mathcal{B}(u)$ (the set of *broken* indices of u) if $u_i - u_{i-1} > z^*$.

For future reference we show that the solutions of

$$\min \{E_1^\sigma(u, v; [0, N]) : v_0 = 0, v_N = Nz, \#\mathcal{B}(u) = n\} \quad (5.33)$$

can be regrouped and rearranged. Let (u, v) solve (5.33). Note that in the union of the non-isolated ‘broken intervals’ we can assume that u and v are affine and equal. More precisely, the convexity of the square and a translation argument allow to prove that there exists z_0 such that if $\underline{i} + k + 1 \in \mathcal{B}(u)$ for $k \in \{0, \dots, \underline{k}\}$, with $\underline{k} \geq 1$ then

$$\begin{aligned} v(\underline{i} + k) &= v(\underline{i}) + z_0 k \quad \text{for } k = 0, \dots, \dots, \underline{k} + 1 \\ v(\underline{i} + k) &= u(\underline{i} + k) \quad \text{for } k = 1, \dots, \underline{k} \end{aligned}$$

(see Figure 22). As a second step, we show that if (u, v) solves (5.33) we can assume that there is at most one ‘broken zone’ for u with length greater than 1. To this end, we extend u and v by periodicity by setting $u(N + j) = u(j) + Nz$ and $u(-j) = u(N - j) - Nz$ for $j = 1, \dots, N$, and correspondingly for v .

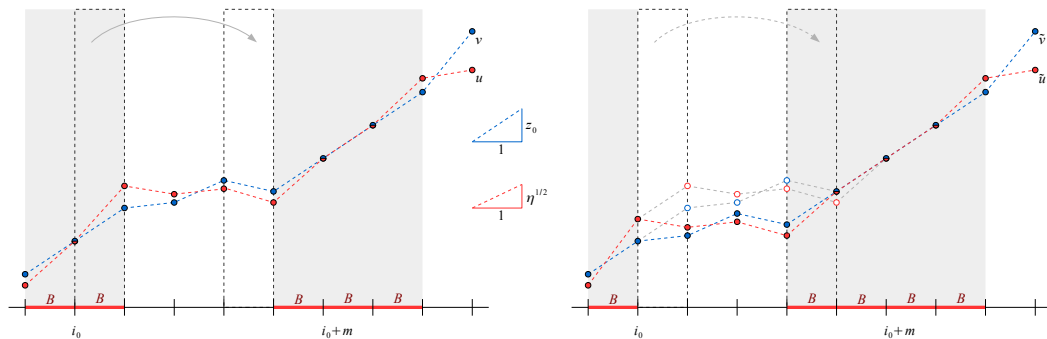

Figure 23: Construction of (u, v) with isolated broken bonds.

Now we show that the minimum is attained at (u, v) such that if $i \in \mathcal{B}(u)$, then $i-1 \notin \mathcal{B}(u)$ and $i+1 \notin \mathcal{B}(u)$, or $j \in \mathcal{B}(u)$ for all $j \in \{i+1, \dots, N\}$. To show this, we suppose that i_0, i_0+1, i_0+k and i_0+k+1 belong to $\mathcal{B}(u)$ for some $i_0 \geq 1, k \geq 2$ and $i_0+k \leq N$, while $i_0+j+1 \notin \mathcal{B}(u)$ for $j \in \{1, \dots, k-2\}$.

We modify u and v by setting for $j = 0, \dots, k-1$

$$\tilde{u}(i_0 + j) = u(i_0 + j + 1) - z_0 \quad \text{and} \quad \tilde{v}(i_0 + j) = v(i_0 + j + 1) - z_0$$

(see Figure 23). With this definition

$$E_1^\sigma(\tilde{u}, \tilde{v}; [0, N]) \leq E_1^\sigma(u, v; [0, N]).$$

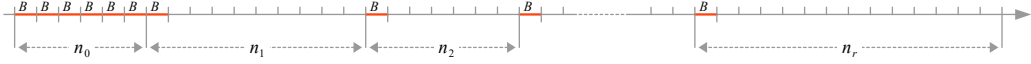

Figure 24: Distribution of broken bonds.

Thanks to the periodic extension of u and v , this proves that in minimum problem (5.33) we can assume that there exist $n_0, n_1, \dots, n_r \in \mathbb{N}$ with $n_l > 1$ for any $l \in \{1, \dots, r\}$, $r + n_0 = n(N, z)$ and $n_0 = N - \sum_{l=1}^r n_l$, such that

$$i \in \mathcal{B}(u) \text{ for all } i \in \{1, \dots, n_0\} \text{ and } \sum_{l=1}^j n_l + 1 \in \mathcal{B}(u) \text{ for all } j \in \{1, \dots, r\} \quad (5.34)$$

(see Figure 24).

This reduces the problem of the computation of the minimum value (5.33) to the solution of the minimum problem on each (translated) island $[0, n_j]$, $j \in \{1, \dots, r\}$,

$$\min \left\{ E_1^\sigma(u, v; [0, n_j]) : v_0 = 0, v_{n_j} = z_j n_j, \mathcal{B}(u) = \{1\} \right\}$$

and in the broken island $[0, n_0]$, where

$$\min \left\{ E_1^\sigma(u, v; [0, n_0]) : v_0 = 0, v_{n_0} = z_0 n_0, \#\mathcal{B}(u) = n_0 \right\} = n_0 g_1(z_0), \quad (5.35)$$

with suitable boundary conditions z_j satisfying $\sum_{j=0}^r n_j z_j = Nz$.

Since $E_1^\sigma(u, v; [0, n-1]) = \tilde{E}_1^\sigma(u, v; [0, n-1]) - b_\sigma(u_0 - v_0)^2$ if $\#\mathcal{B}(u) = 0$, for $n > 1$ and $z \in \mathbb{R}$ we have

$$\begin{aligned} & \min \left\{ E_1^\sigma(u, v; [0, n]) : v_0 = 0, v_n = nz, \mathcal{B}(u) = \{1\} \right\} \\ & \geq \min_{w \in \mathbb{R}} \left\{ \min \left\{ \tilde{E}_1^\sigma(u, v; [1, n]) : v_1 = w, v_n = nz \right\} + a_\sigma w^2 + \tilde{f}(z^*) \right\} \\ & = n g_n^\sigma(z). \end{aligned}$$

5.3.2 General properties of the periodic bounds g_N

In order to relate the constrained relaxation $\hat{Q}_\sigma f(\theta, z)$ to $g_N^\sigma(z)$ and to characterize the locking states of f , we analyze the properties of $g_N^\sigma(z)$ in dependence on both N and z . Note that in the following results we may consider general values of $a, b > 0$ and not limit to a_σ, b_σ , so that the results of this section hold for a general g_N as defined in (5.10).

Proposition 5.17 (convexity of g_N). *The functions g_N are uniformly strictly convex. More precisely, we have*

$$\frac{1}{2}g_N(z) + \frac{1}{2}g_N(z') \geq g_N\left(\frac{z+z'}{2}\right) + a\left(\frac{z-z'}{2}\right)^2 \quad (5.36)$$

for all $z, z' \in \mathbb{R}$ and $N \in \mathbb{N}$.

Proof. If u, v and u', v' are minimizers for $g_N(z)$ and $g_N(z')$ we can use the functions $\frac{1}{2}(u + u')$, $\frac{1}{2}(v + v')$ as test functions for $g_N(\frac{1}{2}(z + z'))$. Using the convexity of \tilde{f} and the quadraticity of the other terms; more precisely, that for all i we have (after setting $v_0 = 0$)

$$a(v_i - v_{i-1})^2 + a(v'_i - v'_{i-1})^2 = \frac{a}{2}((v_i + v'_i) - (v_{i-1} + v'_{i-1}))^2 + \frac{a}{2}((v_i - v_{i-1}) - (v'_i - v'_{i-1}))^2,$$

we get

$$\begin{aligned} \frac{1}{2}g_N(z) + \frac{1}{2}g_N(z') &\geq g_N\left(\frac{z+z'}{2}\right) + \frac{1}{N} \frac{a}{4} \sum_{i=1}^N ((v_i - v_{i-1}) - (v'_i - v'_{i-1}))^2 \\ &\geq g_N\left(\frac{z+z'}{2}\right) + a \left(\frac{1}{2} \frac{1}{N} \sum_{i=1}^N ((v_i - v_{i-1}) - (v'_i - v'_{i-1})) \right)^2 \\ &= g_N\left(\frac{z+z'}{2}\right) + a \left(\frac{z-z'}{2} \right)^2, \end{aligned}$$

as desired. □

Remark 5.18. From the previous proposition we deduce that $g''_N(z) \geq 2a$ at all z where g_N is twice differentiable. In particular, we obtain that $g_N(z) \geq \frac{\tilde{f}(z^*)}{N} + az^2$ for all $N \geq 1$.

Remark 5.19 (symmetry of solutions). The solutions u, v of the minimum problem

$$\min \left\{ \sum_{i=2}^N \tilde{f}(u_i - u_{i-1}) + a \sum_{i=2}^N (v_i - v_{i-1})^2 + b \sum_{i=1}^N (u_i - v_i)^2 : v_1 = v^1, v_N = v^N \right\} \quad (5.37)$$

are symmetric with respect to the centre of the interval, in the sense that

$$v_{j+1} - v_j = v_{N-j+1} - v_{N-j}, \quad u_{j+1} - u_j = u_{N-j+1} - u_{N-j} \quad (5.38)$$

for $1 \leq j \leq N - 1$. Furthermore, if $N = 2M + 1$ is odd then

$$v_{M+1} = u_{M+1} = \frac{v^N + v^1}{2} \quad (5.39)$$

while, if $N = 2M$ is even then

$$\frac{v_{M+1} + v_M}{2} = \frac{u_{M+1} + u_M}{2} = \frac{v^N + v^1}{2}. \quad (5.40)$$

Indeed, first note that we may state the boundary condition equivalently as $v_N - v_1 = V := v^N - v^1$. Then, condition (5.38) is a direct consequence of the strict convexity of the energy and is obtained using

$$\bar{v}_i = \frac{v_i - v_{N+1-i}}{2}, \quad \bar{u}_i = \frac{u_i - u_{N+1-i}}{2} \quad (5.41)$$

as test functions. To check, e.g., (5.39), note that from (5.38)

$$\begin{aligned} v_{M+1} &= v_1 + \sum_{j=1}^M (v_{j+1} - v_j) = v_1 + \sum_{j=1}^M (v_{N-j+1} - v_{N-j}) \\ &= v_1 + \sum_{k=M+1}^{N-1} (v_{k+1} - v_k) = v_N - v_{M+1} + v_1, \end{aligned}$$

from which the first equality in (5.39) follows. To check the second one, note that from (5.38) we obtain $v_i + v_{2M+2-i} - 2v_{M+1} = u_i + u_{2M+2-i} - 2u_{M+1} = 0$ for all i , from which

$$\frac{1}{N} \sum_{i=1}^N u_i = u_{M+1}, \quad \frac{1}{N} \sum_{i=1}^N v_i = v_{M+1}. \quad (5.42)$$

Now, considering in place of u_i the function

$$\bar{u}_i = u_i + \frac{v^1 + v^N}{2} - u_{M+1},$$

as test functions, the only change in the problem in (5.37) is in the last sum, for which, using (5.42) and the already proved equality in (5.39) for v , we have

$$\sum_{i=1}^N (\bar{u}_i - v_i)^2 = \sum_{i=1}^N (u_i - v_i)^2 - N \left(\frac{v^1 + v^N}{2} - u_{M+1} \right)^2,$$

which contradicts the minimality of u, v if the second equality in (5.39) does not hold. The proof of (5.40) follows the same line with minor modifications.

Proposition 5.20 (convexity properties with respect to N with given parity). *For all $N_1, N_2 \geq 1$ such that $N_1 + N_2$ is even and $N_1 \neq N_2$, for all $z_1, z_2 \in \mathbb{R} \setminus \{0\}$ we have*

$$\frac{N_1}{N_1 + N_2} g_{N_1}(z_1) + \frac{N_2}{N_1 + N_2} g_{N_2}(z_2) > g_N(z), \quad (5.43)$$

where $N = \frac{N_1+N_2}{2}$ and $z = \frac{N_1 z_1 + N_2 z_2}{N_1+N_2}$. In particular, we have the convexity property in N

$$\frac{N_1}{N_1+N_2}g_{N_1}(z) + \frac{N_2}{N_1+N_2}g_{N_2}(z) > g_N(z), \text{ where } N = \frac{N_1+N_2}{2} \text{ and } z \neq 0. \quad (5.44)$$

Proof. We consider the case of N_1 and N_2 odd, the case of N_1 and N_2 even following the same line with minor modifications. Let u^1, v^1 be minimizers for $g_{N_1}(z_1)$ and let u^2, v^2 be

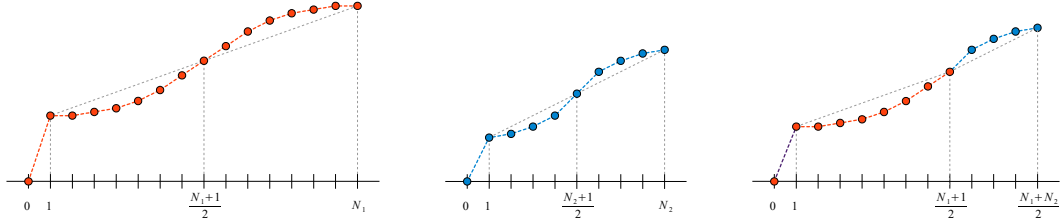

Figure 25: construction of the test function \bar{v} .

minimizers for $g_{N_2}(z_2)$. We define \bar{u}, \bar{v} by setting

$$\bar{v}_i = \begin{cases} v_i^1 + \frac{v_1^2 - v_1^1}{2} & \text{if } 1 \leq i \leq \frac{N_1+1}{2} \\ v_{i+\frac{N_2-N_1}{2}}^2 + \frac{1}{2}(N_1 z_1 + N_2 z_2) & \text{if } i \geq \frac{N_1+1}{2}, \end{cases}$$

$$\bar{u}_i = \begin{cases} u_i^1 + \frac{v_1^2 - v_1^1}{2} & \text{if } 1 \leq i \leq \frac{N_1+1}{2} \\ u_{i+\frac{N_2-N_1}{2}}^2 + \frac{1}{2}(N_1 z_1 + N_2 z_2) & \text{if } i \geq \frac{N_1+1}{2} \end{cases}$$

(see Fig. 25). Thanks to Remark 5.19 this is a good definition, $\bar{v}_{(N_1+1)/2} = \bar{u}_{(N_1+1)/2}$, and we have $\bar{v}_N = \frac{1}{2}(N_1 z_1 + N_2 z_2)$, so that these are test functions for $g_N(z)$. Again, by the symmetry properties of v^1 and v^2 in Remark 5.19 we obtain (5.43). Note the strict inequality, which is proved by noting that \bar{v}_i, \bar{u}_i do not satisfy the properties of minimizers in Remark 5.19. \square

From Proposition 5.20 we deduce a general convexity property which holds also if N_1 and N_2 have different parity. Note that this implies that broken bonds will be equidistributed up to oscillations of a unit, due to incommensurability phenomena.

Corollary 5.21 (convexity properties with respect to arbitrary N). *Let $k, N \geq 2$ be integers, and $w_k, w_0 \in \mathbb{R} \setminus \{0\}$. Then*

$$(N+k)g_{N+k}(w_k) + Ng_N(w_0) > (N+k-1)g_{N+k-1}(w_{k-1}) + (N+1)g_{N+1}(w_1) \quad (5.45)$$

for some w_{k-1}, w_1 such that $(N+1)w_1 + (N+k-1)w_{k-1} = Nw_0 + (N+k)w_k$. Moreover w_{k-1}, w_1 belong to the interval with endpoints w_0 and w_k .

Proof. Let (w_1, \dots, w_{k-2}) be the solution of the linear system given by the equations

$$(N+h)w_h + (N+h-2)w_{h-2} = 2(N+h-1)w_{h-1}$$

for $h = 2, \dots, k$. We can repeat the application of (5.43) to each pair $N_1 = N+h$, $N_2 = N+h-2$ with $h = 2, \dots, k$, by fixing at each step $z_1 = w_h$, $z_2 = w_{h-2}$, obtaining

$$\begin{aligned} (N+k)g_{N+k}(w_k) - (N+k-1)g_{N+k-1}(w_{k-1}) \\ &> (N+k-1)g_{N+k-1}(w_{k-1}) - (N+k-2)g_{N+k-2}(w_{k-2}) \\ &> (N+1)g_{N+1}(w_1) - Ng_N(w_0). \end{aligned}$$

The last part of the claim follows by induction. \square

Now we can show an ordering property of the functions g_N which allows to describe the structure of $\hat{Q}_\sigma f$ in terms of the locking states.

Remark 5.22. If we define the auxiliary functions $\tilde{g}_N(z) = g_N(z) - \frac{\eta}{N}$, then we have $\tilde{g}_N(z) < \tilde{g}_{N+1}(z)$ for all $N \geq 1$ and $z > 0$. This is proved by induction using Proposition 5.20 with $N_1 = N-1$, $N_2 = N+1$ and $z_1 = z_2 = z$, after noting that for $N = 1$ the inequality $\tilde{g}_1(z) < \tilde{g}_2(z)$ is implied by Proposition 5.17 since $\tilde{g}_1(z) = az^2$.

5.3.3 Characterization of locking states

The convexity properties of $g_N(z)$ allow to characterize the locking states of the function f and to give a description of $Q_\sigma f(z)$.

Theorem 5.23 (locking states of $Q_\sigma f$). *Let f be as in (5.28) and let $m_n^\sigma = e^{-\sigma n}$. Then the set of locking states of $Q_\sigma f$ is given by*

$$\left\{ \frac{1}{N} : N \in \mathbb{N}, N \geq 1 \right\} \cup \{0\}.$$

Proof.

Step 1. We prove by induction the monotonicity of the sequence $g_N(z)$ for z large enough. By Proposition 5.20 we obtain that if $g_N(z) \geq g_{N-1}(z)$ then

$$\frac{N-1}{2N}g_N(z) + \frac{N+1}{2N}g_{N+1}(z) \geq \frac{N-1}{2N}g_{N-1}(z) + \frac{N+1}{2N}g_{N+1}(z) > g_N(z);$$

hence,

$$\frac{N+1}{2N}g_{N+1}(z) > \left(1 - \frac{N-1}{2N}\right)g_N(z) = \frac{N+1}{2N}g_N(z).$$

Hence, iterating this argument, we get that the sequence $k \mapsto g_k(z)$ is not decreasing for $k \geq N - 1$ and strictly increasing for $k \geq N$.

Step 2. Now we show that for z large enough then $g_2(z) \geq g_1(z)$. By the growth hypothesis $\tilde{f}(z) \geq c_1 z^2 - c_2$ we get

$$g_2(z) \geq \frac{\tilde{f}(z^*)}{2} - \frac{c_2}{2} + \frac{1}{2} \min \left\{ c_1(u_2 - u_1)^2 + a(2z - v_1)^2 + a(v_1)^2 + b(u_2 - 2z)^2 + b(u_1 - v_1)^2 : u_1, u_2, v_1 \in \mathbb{R} \right\}.$$

By computing the minimum, we obtain

$$g_2(z) \geq \frac{\tilde{f}(z^*)}{2} - \frac{c_2}{2} + \frac{1}{2} \left(\frac{a(2c_1 + b) + bc_1}{2c_1 + b} (2z - v_1)^2 + a(v_1)^2 \right)$$

with

$$v_1 = \frac{a(4c_1 + 2b) + 2bc_1}{a(4c_1 + 2b) + bc_1} z.$$

Hence for z large enough

$$\begin{aligned} g_2(z) &\geq \frac{\tilde{f}(z^*)}{2} - \frac{c_2}{2} + a \left(1 + \frac{bc_1(a(4c_1 + 2b) + bc_1)}{(a(4c_1 + 2b) + bc_1)^2} \right) z^2 \\ &> \tilde{f}(z^*) + az^2 = g_1(z). \end{aligned}$$

From this property and Remark 5.18 we deduce that there exists a unique z_1 such that $g_2(z_1) = g_1(z_1)$, and hence $g_1(z) = \min_N g_N(z)$ in $[z_1, +\infty)$ by Step 1.

Step 3. By Step 1 we know that $g_N(z_1) > g_2(z_1) = g_1(z_1)$ for all $N \geq 3$. Let $[z_2, z_1]$ be the maximal interval containing z_1 where $g_2(z) = \min_{N \geq 1} g_N(z) = \min_{N \geq 2} g_N(z)$. Since in particular $g_3 > g_2$ in the interval $(z_2, z_1]$ by Remark 5.22, we have $g_N > g_4 > g_3$ for all $N > 4$ in the closed interval $[z_2, z_1]$ always by Step 1. This implies that $g_3(z_2) = g_2(z_2)$. Moreover, note that $g_4(z_2) > g_2(z_2)$, since otherwise we would have $g_3(z_2) < g_2(z_2)$ by (5.44) with $z = z_2$, $N_1 = 2$ and $N_2 = 4$.

Step 4. We define $z_3 = \max\{z : g_4(z) \leq \min\{g_3(z), g_2(z), g_1(z)\}\}$. This is well defined since $g_4(0) < \min\{g_3(0), g_2(0), g_1(0)\}$ and we have $z_3 < z_2$. Note that in (z_4, z_3) we have $\min\{g_N(z) : z \in \mathbb{N}\} \in \{g_2(z), g_3(z)\}$. We then define iteratively $z_n = \max\{z : g_{n+1}(z) \leq \min\{g_k(z) : k \leq n\}\}$. Again, this is a good definition and $z_n < z_{n-1}$. In (z_n, z_{n-1}) we have that $\min\{g_N(z) : N \in \mathbb{N}\} \in \{g_n(z), g_{n-1}(z)\}$. Indeed, by Corollary 5.21 if $g_k(z) = g_\ell(z)$ at some z then $|k - \ell| \leq 1$. Since $\min\{g_N(z_{n-1}) : N \in \mathbb{N}\} = g_n(z_{n-1})$ and we cannot have $g_n(z) = g_{n+1}(z)$ if $z \in (z_n, z_{n-1})$, the claim follows.

Step 5. Inequality (5.44) shows that the graph of g_N lies below the graph of the convex envelope of the minimum between g_{N-1} and g_{N+1} in an open interval. By Proposition 5.14 this proves that $\frac{1}{N}$ is a locking state. \square

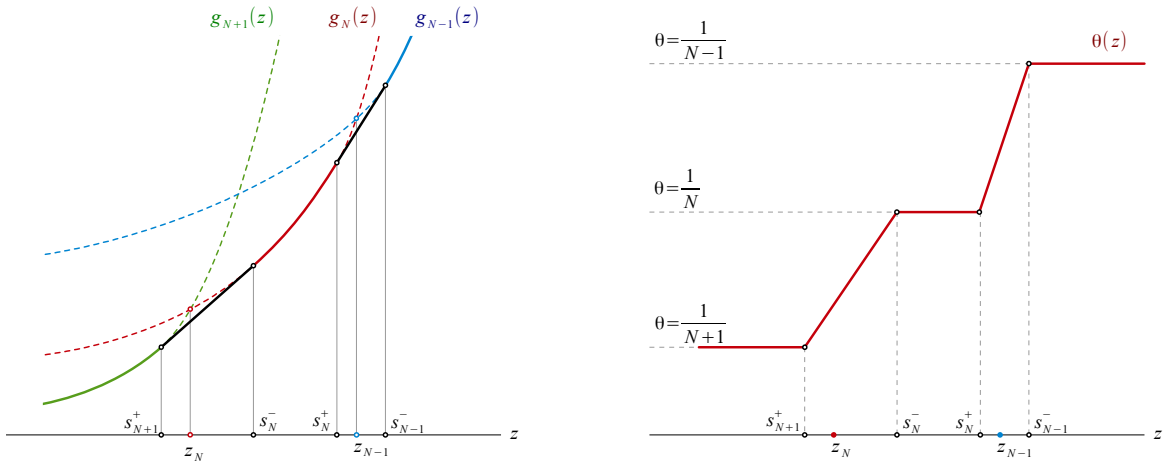

Figure 26: pictorial description of Theorem 5.23 for a single choice of σ (shape of $\widehat{Q}_\sigma f$ and θ , not to scale)

In order to highlight the dependence on σ , for any $\sigma > 0$ and for any $N \geq 1$, in the sequel $z_N(\sigma)$ will denote the corresponding value z_N given by Theorem 5.23. Moreover, for any σ we set $z_0(\sigma) = +\infty$.

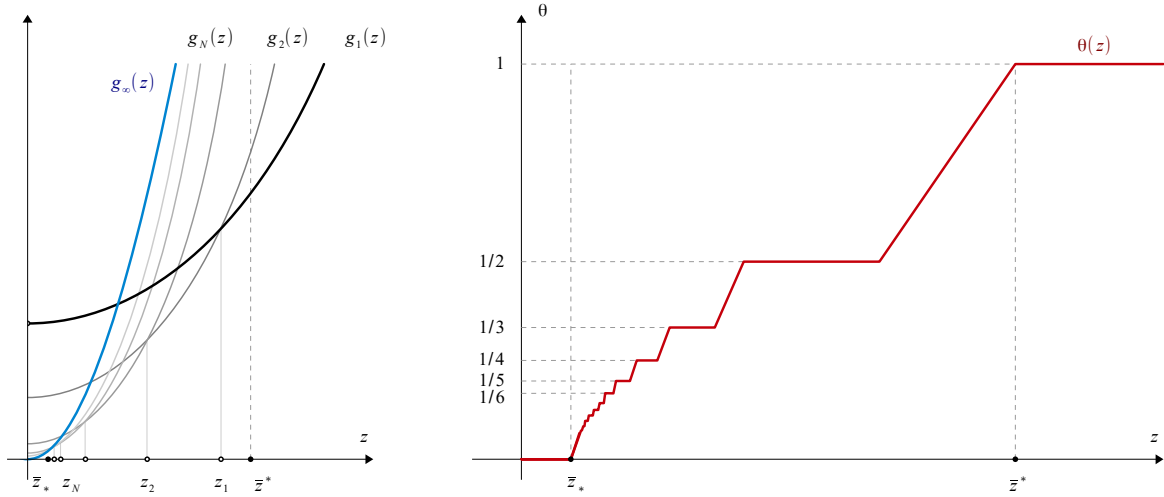

Figure 27: relative behaviour of g_N^σ and the final resulting θ .

Remark 5.24 (shape of $Q_\sigma f(z)$ and $\theta(z)$). The graph of the function $Q_\sigma f(z)$ possesses infinitely many concave parabolic arcs, corresponding to the intervals where $\widehat{Q}_\sigma f(z)$ is affine,

which accumulates in $\bar{z}_*(\sigma) = \inf_N z_N(\sigma) > 0$. Correspondingly, the phase function $\theta(z)$ is affine, interpolating between consecutive values $1/N$ (see Fig. 27).

Summarizing, the behaviour of the penalized energy $Q_\sigma f(z)$ in terms of the macroscopic gradient z has the following features:

- (‘unfractured zone’) for $z \leq \bar{z}_*(\sigma)$ optimal sequences take into account only the convex part of f ; i.e., there are no broken bonds;
- (‘completely microfractured zone’) there exists $\bar{z}^*(\sigma) = s_1^-(\sigma) > z_1(\sigma)$ such that for $z \geq \bar{z}^*(\sigma)$ (that is, in $I_1(\sigma) = [\bar{z}^*(\sigma), +\infty)$) the part of the energy involving the function f is identically $\tilde{f}(z^*)$; i.e., we have broken bonds for all values of the index i ;
- (increasingly segmented behavior of the relaxed energy) for values of the macroscopic gradient between $\bar{z}_*(\sigma)$ and $\bar{z}^*(\sigma)$ the energy $\widehat{Q}_\sigma f$ behaves as a superposition of infinitely many ‘damaged materials’ indexed by the parameter N representing the microscopic optimal spacing of broken bonds. For the values z where $\widehat{Q}_\sigma f(z)$ is affine, optimal sequences mix the damaged materials parameterized by N and $N - 1$. The point $\bar{z}_*(\sigma)$ is an accumulation point for the different behaviors as $N \rightarrow +\infty$.

Remark 5.25 (limit behaviours of the damaged zones). By Proposition 2.38, highlighting the dependence on the parameter σ , we deduce that

- (i) $\lim_{\sigma \rightarrow 0} \bar{z}_*(\sigma) = \lim_{\sigma \rightarrow 0} \bar{z}^*(\sigma) = z^*$, corresponding to the extreme non-additivity case,
- (ii) $\lim_{\sigma \rightarrow +\infty} \bar{z}_*(\sigma) = 0$ and $\lim_{\sigma \rightarrow +\infty} \bar{z}^*(\sigma) = +\infty$, corresponding to full additivity.

Remark 5.26 (Generic non differentiability). Note the generic non differentiability of $\widehat{Q}_\sigma f(\theta, z)$ with respect to θ at the locking states. This is due to the different definitions of this function in left and right neighbourhoods of each locking state $\frac{1}{N}$. Indeed, the definition of $\widehat{Q}_\sigma f(\theta, z)$ uses $g_N^\sigma(z), g_{N+1}^\sigma(z)$ in a left neighbourhood and $g_{N-1}^\sigma(z), g_N^\sigma(z)$ in a right neighbourhood of $\theta = \frac{1}{N}$, respectively, in analogy with the case of concentrated kernels, as seen in Section 4 (see Remark 4.5).

5.4 Properties of optimal microstructures

In the previous section we have shown that θ of the form $\frac{1}{N}$ with $N \in \mathbb{N}$ are locking states. We now show that such values correspond to energy wells, and characterize all $\widehat{Q}_\sigma f(\theta, \cdot)$.

5.4.1 Microstructures as interpolations of energy meta-wells

The following proposition reinterprets g_N^σ as the energy of periodic minimizers for $\theta_N = 1/N$.

Proposition 5.27 (g_N^σ as an energy meta-well). *Let g_N^σ be defined as in (5.30) with $a = a_\sigma$ and $b = b_\sigma$ satisfying (5.17). The following equality holds for any $N \in \mathbb{N}$ and $z \in \mathbb{R}$:*

$$\Phi_{\mathbf{m}}^N f\left(\frac{1}{N}, z\right) = g_N^\sigma(z)$$

where $\Phi_{\mathbf{m}}^N f$ is defined in (3.21) with $A = [z^*, +\infty)$, $f_{-1} = \tilde{f}$, $f_1 = \tilde{f}(z^*)$ if $z \in A$ and $+\infty$ otherwise, and $m_n = e^{-\sigma n}$.

Proof. We first observe that $\Phi_{\mathbf{m}}^N f(\frac{1}{N}, z) = \widehat{R}_{\mathbf{m}}^N f(\underline{s}_N, z)$ where $\underline{s}_N = (1, -1, -1, \dots, -1)$ and $\widehat{R}_{\mathbf{m}}^N f$ is defined in (3.20) with

$$F^\#(u, \underline{s}; [0, N]) = \sum_{i=1}^N f_{s_i}(u_i - u_{i-1}) + \sum_{i=1}^N \sum_{j \in \mathbb{Z}} e^{-\sigma|i-j|} (u_i - u_j)^2.$$

By extending \underline{s}_N by N -periodicity, we have

$$\begin{aligned} \widehat{R}_{\mathbf{m}}^N f(\underline{s}_N, z) &= \frac{1}{N} \min\{F^\#(u, \underline{s}_N; [0, N]) : u_i - zi \text{ } N\text{-periodic}\} \\ &= \lim_{k \rightarrow +\infty} \frac{1}{kN} \min\{F^\#(u, \underline{s}_N; [0, kN]) : u_i - zi \text{ } N\text{-periodic}\} \\ &= \lim_{k \rightarrow +\infty} \frac{1}{kN} \min \left\{ \tilde{f}(z^*)k + \sum_{r=1}^k \sum_{l=2}^N \tilde{f}(u_{N(r-1)+l} - u_{N(r-1)+l-1}) \right. \\ &\quad \left. + a_\sigma \sum_{i=1}^{kN} (v_i - v_{i-1})^2 + b_\sigma \sum_{i=1}^{kN} (u_i - v_i)^2 : u_i - zi, v_i - zi \text{ } N\text{-periodic} \right\}, \end{aligned}$$

the last equality being a consequence of (5.4), the equivalence result of Lemma 5.9 and the characterization of the minima given by (5.6), which ensures that also the minimizing v can be chosen periodic. Hence by the periodicity we get

$$\Phi_{\mathbf{m}}^N f\left(\frac{1}{N}, z\right) = \frac{1}{N} \min \left\{ \tilde{f}(z^*) + \sum_{i=2}^N \tilde{f}(u_i - u_{i-1}) + a_\sigma \sum_{i=1}^N (v_i - v_{i-1})^2 + b_\sigma \sum_{i=1}^N (u_i - v_i)^2 : \right. \\ \left. u_i - zi, v_i - zi \text{ } N\text{-periodic} \right\}.$$

Finally, noting that we can remove the periodicity condition on u and that we can rewrite the condition on v as a boundary condition, we get the claim. \square

Let $I_N = I_N(\sigma) = \{z \in \mathbb{R} : \widehat{Q}_\sigma f(z) = g_N^\sigma(z)\}$. Note that Remark 5.11 implies that $\widehat{Q}_\sigma f(\theta, \cdot)$ can be described in terms of the convex combination of the functions $g_N^\sigma(z)$. In particular, by the convexity of $g_N^\sigma(z)$ with respect to N , we have

$$\widehat{Q}_\sigma f\left(\frac{1}{N}, z\right) = g_N^\sigma(z) \tag{5.46}$$

in the whole \mathbb{R} .

We are now in a position to characterize $\widehat{Q}_\sigma f(\theta, \cdot)$ as an interpolation between consecutive energy meta-wells (corresponding to the locking states), as in Lemma 4.4 for the concentrated kernels.

Proposition 5.28 (interpolation between energy wells). *Given $\sigma > 0$, suppose that $a = a_\sigma$ and $b = b_\sigma$ are as in (5.17). Then, for any $\theta \in \mathbb{Q} \cap (0, 1)$ and for any $z \in \mathbb{R}$ the following equality holds:*

$$\widehat{Q}_\sigma f(\theta, z) = \min \left\{ t(\theta)g_{N_\theta}^\sigma(z') + (1 - t(\theta))g_{N_\theta+1}^\sigma(z'') : t(\theta)z' + (1 - t(\theta))z'' = z \right\}, \quad (5.47)$$

where

$$N_\theta = \left\lfloor \frac{1}{\theta} \right\rfloor \quad \text{and} \quad t(\theta) = N_\theta(\theta(N_\theta + 1) - 1). \quad (5.48)$$

Proof. We divide the proof in two steps.

Step 1: $\theta = \frac{1}{N}$. In this case, the claim becomes (5.46) for all $z \in \mathbb{R}$. We note that for each N the formula is proved for $z \in I_N$. Moreover, for arbitrary z it can be further simplified as follows. Let $k \in \mathbb{N}$ be fixed and let (u, v) be a minimizer in (5.27) with $p = 1$ and $q = N$. Since $\widehat{Q}_\sigma f(\frac{1}{N}, z)$ can be expressed as in (5.27), it is sufficient to show that for all k

$$\frac{1}{kN} E_1^\sigma(u, v; [0, kN]) \geq g_N^\sigma(z).$$

It is not restrictive to suppose that $u_1 - u_0 \geq z^*$. By grouping the interactions, we estimate

$$E_1^\sigma(u, v; [0, kN]) \geq \sum_{j=1}^k N_j g_{N_j}^\sigma(z_j)$$

where $\sum_{j=1}^k N_j = kN$ and $\sum_{j=1}^k N_j z_j = kNz$. By Proposition 5.20, we infer that all even N_j are equal to some N_e , and the corresponding z_j coincide with some z_e , and the same holds for odd N_j with N_o and corresponding z_j with z_o , so that there exist integers k_e and k_o such that

$$E_1^\sigma(u, v; [0, kN]) \geq k_e N_e g_{N_e}^\sigma(z_e) + k_o N_o g_{N_o}^\sigma(z_o)$$

where

$$k_e N_e + k_o N_o = kN \quad \text{and} \quad k_e N_e z_e + k_o N_o z_o = kNz.$$

Since $u \in \mathcal{V}(kN, \frac{1}{N})$, we also have $k_e + k_o = k$. By (5.45) we deduce that $|N_e - N_o| = 1$, and this is only possible if either k_e or k_o vanishes, from which we conclude.

Step 2: general case. We fix $\theta = \frac{p}{q}$ with p and q coprime integers satisfying $1 < p < q$. Let $k \in \mathbb{N}$ be fixed and let (u, v) be a minimizer in (5.27). By grouping the interactions as in the case $\theta = \frac{1}{N}$, thanks to (5.45) we obtain that there exists $N \in \mathbb{N}$ such that

$$k_1 + k_2 = kp, \quad k_1 N + k_2(N + 1) = kq \quad (5.49)$$

for some $k_1, k_2 \in \mathbb{N}$, and

$$E_1^\sigma(u, v; [0, kq]) \geq k_1 N g_N^\sigma(z') + k_2(N + 1) g_{N+1}^\sigma(z'')$$

where z', z'' satisfy $k_1 N z' + k_2 (N+1) z'' = k q z$. Since (5.49) implies $\frac{q}{p} \geq N > \frac{q}{p} - 1$, we deduce that $N = N_\theta$ is the unique integer solution of the equation (with $k_1 = k(p(N_\theta + 1) - q) > 0$ and $k_2 = k(q - p N_\theta) > 0$). Hence

$$E_1^\sigma(u, v; [0, kq]) \geq k_1 N_\theta g_{N_\theta}^\sigma(z') + k_2 (N_\theta + 1) g_{N_\theta+1}^\sigma(z''). \quad (5.50)$$

Noting that

$$\frac{k_1 N_\theta}{kq} = t(\theta) \quad \text{and} \quad \frac{k_2 (N_\theta + 1)}{kq} = 1 - t(\theta),$$

since $\widehat{Q}_\sigma f(\theta, z)$ can be expressed as in (5.27) we obtain, by using (5.50),

$$\widehat{Q}_\sigma f(\theta, z) \geq \min \left\{ t(\theta) g_{N_\theta}^\sigma(z') + (1 - t(\theta)) g_{N_\theta+1}^\sigma(z'') : t(\theta) z' + (1 - t(\theta)) z'' = z \right\}.$$

The opposite inequality follows by the equality $g_N^\sigma(z) = \widehat{Q}_\sigma f(\frac{1}{N}, z)$ proved in the case $\theta = \frac{1}{N}$ and by the convexity of $\widehat{Q}_\sigma f(\theta, z)$. Indeed, noting that

$$\frac{t(\theta)}{N_\theta} + \frac{1 - t(\theta)}{N_\theta + 1} = \theta,$$

for all pairs (z', z'') such that $t(\theta) z' + (1 - t(\theta)) z'' = z$, we have

$$\begin{aligned} t(\theta) g_{N_\theta}^\sigma(z') + (1 - t(\theta)) g_{N_\theta+1}^\sigma(z'') &= t(\theta) \widehat{Q}_\sigma f\left(\frac{1}{N_\theta}, z'\right) + (1 - t(\theta)) \widehat{Q}_\sigma f\left(\frac{1}{N_\theta + 1}, z''\right) \\ &\geq \widehat{Q}_\sigma f\left(\frac{t(\theta)}{N_\theta} + \frac{1 - t(\theta)}{N_\theta + 1}, t(\theta) z' + (1 - t(\theta)) z''\right) \\ &\geq \widehat{Q}_\sigma f(\theta, z) \end{aligned}$$

as desired. □

5.4.2 A canonical optimal microstructure uniform at all scales

The description of $\widehat{Q}_\sigma f$ that we have obtained in terms of g_N^σ highlights a number of equivalent minimizers. However, in this class we can define a set of canonical ground states. These states are characterized by the corresponding distribution of spins, or, equivalently, the distribution of broken bonds. Similar sets have independently appeared in the study of related dynamical systems [9, 79].

In order to describe this optimal distribution of broken bonds, for a given $\theta \in [0, 1]$ we define the set of integers

$$A(\theta) = \{k \in \mathbb{Z} : \lfloor k\theta \rfloor \neq \lfloor (k+1)\theta \rfloor\}.$$

A characteristic property of the set $A(\theta)$ is its ‘uniformity at all scales’; that is, the property that for each $M \in \mathbb{N}$ each interval of length M contains either $\lfloor M\theta \rfloor$ or $\lfloor M\theta \rfloor + 1$ elements of $A(\theta)$. The set $A(\theta)$ can be described as the most uniformly distributed among sets with such property (up to translations). Note, for instance, that if $\frac{1}{N+1} < \theta < \frac{1}{N}$ then the difference between two consecutive elements of $A(\theta)$ is either N or $N + 1$. The set $A(\theta)$ is periodic if and only if θ is rational; otherwise it follows a pattern reminiscent of quasiperiodic functions (see e.g. [16, 74]).

The following proposition states that in the computation of $\widehat{Q}_\sigma f(z)$ we can consider the corresponding minimum problems only on functions u whose broken sites coincide with $A(\theta(z))$.

Proposition 5.29 (optimality of $A(\theta)$). *Let f be as in (5.28). Then, for any $\sigma > 0$ and $z \in \mathbb{R}$, the following equality holds:*

$$\widehat{Q}_\sigma f(z) = \liminf_{\substack{k \rightarrow +\infty \\ k \in A(\theta(z))}} \frac{1}{k} \min\{E_1^\sigma(u, v; [0, k]) : v_0 = 0, v_k = zk, u_i - u_{i-1} \geq z^* \Leftrightarrow i \in A(\theta(z))\}.$$

Proof. For each N , we can suppose that the set where $\widehat{Q}_\sigma f(z) = g_N^\sigma(z)$ is a closed interval I_N , which we let $I_N = [s_N^-, s_N^+]$. Note that the intervals are ordered as in Fig. 26; that is, $s_{N+1}^+ < s_N^-$.

Let $z \in (s_{N+1}^+, s_N^-)$. Then, writing

$$z = ts_N^- + (1-t)s_{N+1}^+, \quad (5.51)$$

we have that

$$\widehat{Q}_\sigma f(z) = r_{N+1}^\sigma(z) = tg_N^\sigma(s_N^-) + (1-t)g_{N+1}^\sigma(s_{N+1}^+). \quad (5.52)$$

Recalling the definition of the phase function $\theta(z)$ (see Definition 3.6) and the fact that $\theta(z)$ is affine in each open interval where $\widehat{Q}_\sigma f$ is affine, as stated in Proposition 3.10, we deduce

$$\widehat{Q}_\sigma f(z) = \widehat{Q}_\sigma f(\theta(z), z) \quad \text{and} \quad \theta(z) = t\frac{1}{N} + (1-t)\frac{1}{N+1},$$

where the link between z, t and N is given by (5.51). Hence, using the local representation given by (5.27), for all $k \in A(\theta(z))$ we can split the minimum

$$\min\{E_1^\sigma(u, v; [0, k]) : v_0 = 0, v_k = zk, u_i - u_{i-1} \geq z^* \Leftrightarrow i \in A(\theta(z))\}$$

into the sum of the minima

$$M_j = \min\{E_1(u, v; [i_{j-1}, i_j]) : v_{i_{j-1}} = 0, v_{i_j} = (i_j - i_{j-1})z_j, u_i - u_{i-1} \geq z^* \Leftrightarrow i = i_j\},$$

where $A(\theta(z)) \cap [0, k] = \{i_0, i_1, \dots, i_{n_k}\}$ with $0 = i_0 < \dots < i_{n_k} = k$, and z_j are such that $\sum_{j=1}^{n_k} (i_j - i_{j-1})z_j = kz$.

Furthermore, noting that $M_j = (i_j - i_{j-1})g_{i_j - i_{j-1}}^\sigma(z_j)$, we obtain by convexity

$$\begin{aligned} & \frac{1}{k} \min\{E_1(u, v; [0, k]) : v_0 = 0, v_k = zk, u_i - u_{i-1} \geq z^* \Leftrightarrow i \in A(\theta(z))\} \\ & \geq \frac{1}{k} \sum_{j=1}^{n_k} (i_j - i_{j-1})g_{i_j - i_{j-1}}^\sigma(z_j) \geq \frac{1}{k} \sum_{j=1}^{n_k} (i_j - i_{j-1})\widehat{Q}_\sigma f(z_j) \geq \widehat{Q}_\sigma f(z). \end{aligned} \quad (5.53)$$

Conversely, fixed $k \in A(\theta(z))$, let $\mathcal{I}_N = \{j \leq n_k : i_j - i_{j-1} = N\}$ and $\mathcal{I}_{N+1} = \{j \leq n_k : i_j - i_{j-1} = N + 1\}$ and z_k^\pm be such that

$$N\#\mathcal{I}_N z_k^- + (N + 1)\#\mathcal{I}_{N+1} z_k^+ = kz$$

and $z_k^- \rightarrow s_N^-, z_k^+ \rightarrow s_{N+1}^+$ as $k \rightarrow +\infty$. Then, using the minimizers of $g_N^\sigma(z_k^-)$ and of $g_{N+1}^\sigma(z_k^+)$ to test the minimum problem in (5.53), we get the upper bound

$$N\#\mathcal{I}_N g_N^\sigma(z_k^-) + (N + 1)\#\mathcal{I}_{N+1} g_{N+1}^\sigma(z_k^+).$$

Taking the limit as $k \rightarrow +\infty$, by (5.52) we obtain the claim. \square

Remark 5.30 (optimality of $A(\theta)$ for the constrained relaxation). The same proof shows that for any θ

$$\widehat{Q}_\sigma f(\theta, z) = \liminf_{\substack{k \rightarrow +\infty \\ k \in A(\theta)}} \frac{1}{k} \min\{E_1^\sigma(u, v; [0, k]) : v_0 = 0, v_k = zk, u_i - u_{i-1} \geq z^* \Leftrightarrow i \in A(\theta)\}.$$

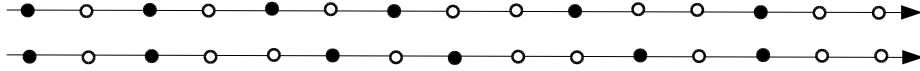

Figure 28: representation of two periodic minimizers

For the sake of illustration, in Fig. 28 we represent two periodic minimizers (the black dots representing broken bonds) for $\theta = 2/5$. In the first case we have a 15-periodic minimizers, the second array is the ‘canonical’ one, alternating broken bonds at distance two and three.

Remark 5.31 (the M -th neighbour case). In the case of M -th only interactions, we focus first on $\theta = \theta_k = \frac{k}{M}$, with $k \in \{0, \dots, M\}$, that is, on locking states, or, equivalently, on energy wells. The construction in Proposition 4.4 shows that all periodic spin configurations with period a submultiple of M compatible with θ_k , correspond to optimal laminates. Indeed, the only requirement on minimizers is that for all intervals of length M we have an equal number of spins of either type (which is trivially true). Note in particular that we may choose minimizers with $u_i - u_{i-1} > z^*$ exactly for $i \in A(\theta)$ since this set is M -periodic. Now if θ is not of the form k/M , we do not have periodic optimal minimizers. This is in contrast to the exponential case, where we do have periodic minimizers for all $\theta \in \mathbb{Q}$.

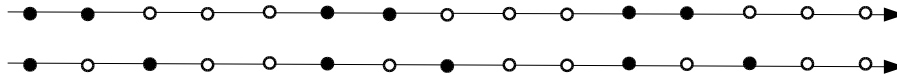

Figure 29: representation of two periodic minimizers

In Fig. 29 we represent two 5-periodic minimizers (the black dots representing the elongations larger than z^*) for $M = 5$ and $\theta = 2/5$. The second array is the ‘canonical’ one, alternating broken bonds at distance two and three.

We note that in some of our examples illustrating periodic minimizers with ‘global’ properties, the canonical periodic microstructures, epitomizing a generalized Cauchy-Born (GCB) states, are unique. This is true, for instance, in the case of the exponential kernel \mathbf{m} . Instead, for concentrated kernels we may have more than one minimal (GCB-type) microstructure. Note also that in the case of exponential kernels, outside the special regimes where the minimizers are periodic, we can mix GCB states and, since different GCB states do not interact, the mixing process is bringing arbitrariness. In particular, GCB states could be mixed canonically, even though in the examples of interest in this paper this does not bring any advantages. However, this is not the general case and when different GCB states interact, their mixtures can become suboptimal, as in the case of concentrated kernels. We argue that in such ‘strongly non-additive’ cases the non-periodic GCB states with the properties of our canonical microstructures can become the preferred ones if interaction happens at all scales (which is not the case for concentrated kernels).

5.5 Explicit constructions

In this section we explicitly compute $Q_\sigma f$ in a meaningful case, using the general results of the previous section. This also allows us to treat some classes of energies more general than truncated potentials.

5.5.1 The Novak-Truskinovsky model

Let f be the truncated quadratic potential defined as in (5.28) with $\tilde{f}(z) = z^2$; that is,

$$f(z) = \begin{cases} z^2 & \text{if } z \leq \sqrt{\eta} \\ \eta & \text{if } z \geq \sqrt{\eta} \end{cases} \quad (5.54)$$

with $\eta > 0$ fixed. By using the computations in [84] and the results of this section, we obtain an explicit formula for $g_N^\sigma(z)$, and hence $Q_\sigma f(z)$.

Remark 5.32 (explicit computation of minima). Let \tilde{E}_1 be defined as in (5.29) with $\tilde{f}(z) = z^2$

and $a, b > 0$. Then, by the computations in [84, Sec. 3] we get

$$\min\{\tilde{E}_1(u, v; [0, N]) : v_0 = 0, v_N = N\} = \frac{N^2 a(a+1)}{Na + \tanh((N+1)\zeta) \coth(\zeta) - 1}$$

where

$$\zeta = 2 \sinh^{-1} \left(\frac{1}{2} \sqrt{\frac{b(a+1)}{a}} \right). \quad (5.55)$$

By using (5.30), we obtain

$$g_N(z) = c_N z^2 + \frac{\eta}{N}, \quad (5.56)$$

where

$$c_N = \frac{Na(a+1)}{Na + \tanh(N\zeta) \coth(\zeta)} \quad (5.57)$$

and ζ as in (5.55).

Since we are interested in the analysis of $Q_\sigma f$, if $a = a_\sigma$ and $b = b_\sigma$ satisfy (5.17) we write g_N^σ, c_N^σ and ζ_σ in place of g_N, c_N and ζ , respectively. The interval where $\widehat{Q}_\sigma f(z) = g_N^\sigma(z)$ is given by $I_N(\sigma) = [s_N^-, s_N^+]$, where

$$\begin{aligned} s_N^+ &= s_N^+(\sigma) = \sqrt{\frac{\eta}{N(N-1)(c_N^\sigma - c_{N-1}^\sigma)}} \sqrt{\frac{c_{N-1}^\sigma}{c_N^\sigma}} \quad \text{if } N \geq 2; \quad s_1^+ = s_1^+(\sigma) = +\infty \\ s_N^- &= s_N^-(\sigma) = \sqrt{\frac{\eta}{(N+1)N(c_{N+1}^\sigma - c_N^\sigma)}} \sqrt{\frac{c_{N+1}^\sigma}{c_N^\sigma}} \quad \text{if } N \geq 1. \end{aligned} \quad (5.58)$$

Hence,

$$\bar{z}_*(\sigma) = \lim_{N \rightarrow +\infty} s_N^\pm = \sqrt{\frac{a_\sigma \eta}{(a_\sigma + 1) \coth(\zeta_\sigma)}} \quad \text{and} \quad \bar{z}^*(\sigma) = s_1^- = \sqrt{\frac{\eta(2a_\sigma + b_\sigma(a_\sigma + 1))}{a_\sigma b_\sigma}}. \quad (5.59)$$

Note that $\bar{z}_*(\sigma) > \sqrt{a_\sigma \eta}$. Concluding, we have

$$Q_\sigma f(z) = \begin{cases} z^2 & \text{if } z \leq \bar{z}_*(\sigma) \\ g_N^\sigma(z) - a_\sigma z^2 & \text{if } s_N^- \leq z \leq s_N^+ \text{ for some } N \geq 2 \\ r_{N+1}^\sigma(z) - a_\sigma z^2 & \text{if } s_{N+1}^+ \leq z \leq s_N^- \text{ for some } N \\ \eta & \text{if } z \geq \bar{z}^*(\sigma), \end{cases} \quad (5.60)$$

where $r_{N+1}^\sigma(z)$ is the common tangent to $g_{N+1}^\sigma(z)$ and $g_N^\sigma(z)$.

The phase function θ corresponding to this example is pictured in Fig. 30, where the grey zones between pair of curves denote the pairs in the z - $\frac{1}{\sigma}$ plane in which θ is affine for fixed σ between consecutive value of the form $\frac{1}{N}$.

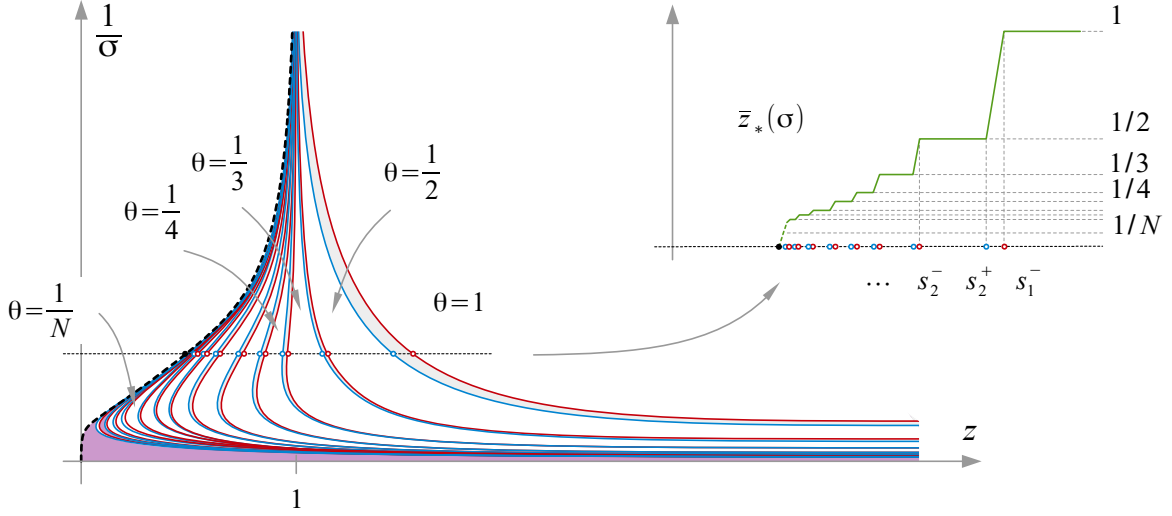

Figure 30: representation of θ in the $z - \frac{1}{\sigma}$ plane and a cross section at fixed σ .

5.5.2 Interpolation between varying degrees of non convexity

In this setting it is also of interest to consider a broader class of non convex convex-affine functions f which includes the convex-constant functions as particular cases. More specifically, consider the functions ℓ_f^τ defined by

$$\ell_f^\tau(z) = \begin{cases} f(z) & \text{if } z \leq z^* \\ f(z^*) + \tau f'(z^*)(z - z^*) & \text{if } z > z^* \end{cases} \quad (5.61)$$

with $0 < \tau < 1$. In this way we construct an interpolation between the constrained relaxation of the truncated-convex potential and of the convex potential which is obtained if beyond z^* we smoothly extend f in an affine way. Accordingly, in (5.61) we have the truncated-convex potential as above at $\tau = 0$, while at $\tau = 1$ the function ℓ_f^1 is convex.

We can write $\ell_f^\tau(z) = \Phi^\tau(z) + \Gamma^\tau(z)$, where

$$\Gamma^\tau(z) = f(z^*) + \tau f'(z^*)(z - z^*)$$

and

$$\Phi^\tau(z) = \begin{cases} f(z) - \tau f'(z^*)(z - z^*) & \text{if } z \leq z^* \\ f(z^*) & \text{if } z > z^*. \end{cases}$$

The function Φ^τ is a truncated convex potential to which we can apply the results above, while, by Remark 2.25(iii) we have

$$Q_\sigma \ell_f^\tau = Q_\sigma(\Phi^\tau + \Gamma^\tau) = Q_\sigma(\Phi^\tau) + \Gamma^\tau.$$

We can carry on this computation for the quadratic-affine functions ℓ^τ defined in (3.18); that is, ℓ_f^τ with $f(z) = z^2$ and $z^* = \sqrt{\eta}$. Note that we can equivalently rewrite $\ell^\tau(z) = \tilde{\Phi}^\tau(z) + \tilde{\Gamma}^\tau(z)$, where $\tilde{\Gamma}^\tau(z) = 2\tau z - \tau^2$ and

$$\tilde{\Phi}^\tau(z) = \begin{cases} (z - \tau)^2 & \text{if } z \leq 1 \\ (1 - \tau)^2 & \text{if } z > 1, \end{cases}$$

which can be seen as a translation by τ of the function Ψ^τ given by

$$\Psi^\tau(z) = \begin{cases} z^2 & \text{if } z \leq 1 - \tau \\ (1 - \tau)^2 & \text{if } z > 1 - \tau. \end{cases}$$

The latter is exactly of the form considered in Example 5.5.1 with $\eta = \eta^\tau = (1 - \tau)^2$. Its constrained relaxation is then described in (5.60), and we eventually have

$$Q_\sigma \ell^\tau(z) = (Q_\sigma \Psi^\tau)(z - \tau) + 2\tau z - \tau^2.$$

Note that by (5.59) the endpoints of the interval where the corresponding $\theta(z)$ is not 0 or 1 are

$$\bar{z}_{*,\tau}(\sigma) = \tau + (1 - \tau) \sqrt{\frac{a_\sigma}{(a_\sigma + 1) \coth(\zeta_\sigma)}} \quad \text{and} \quad \bar{z}^{*,\tau}(\sigma) = \tau + (1 - \tau) \sqrt{\frac{2a_\sigma + b_\sigma(a_\sigma + 1)}{a_\sigma b_\sigma}},$$

with $a_\sigma, b_\sigma, \zeta_\sigma$ as in Example 5.5.1. Note that $\bar{z}_{*,\tau}(\sigma) < 1 < \bar{z}^{*,\tau}(\sigma)$, and $\lim_{\tau \rightarrow 1^-} \bar{z}_{*,\tau}(\sigma) = \lim_{\tau \rightarrow 1^-} \bar{z}^{*,\tau}(\sigma) = 1$.

6 Asymptotically equivalent continuum models

The goal of the relaxation of the discrete problems discussed in this paper was to obtain a homogenized continuum model. We have seen that generically the presence of nonlocal interactions prevents even the simplest non-convex 1D problem from being fully characterized by a bulk continuum energy. It follows from our analysis that the exceptions, when the ‘local’ description also has ‘global’ features and the generalized Cauchy-Born rule is applicable, are extremely rare. Then the question arises regarding the very nature of the continuum model which could be considered as asymptotically equivalent to a discrete model carrying both non-convexity and incompatibility induced by nonlocal interactions. In this section we present an explicit example showing that the answer to this question may be nontrivial. While our analysis here will not be exhaustive, it points towards a new class of hybrid discrete-continuum variational problems which may be of a considerable interest *per se*.

In the interest of analytical transparency we focus on the specific homogenization problem for energies E_ε with the truncated quadratic potential f given by (5.54); that is, the NT

model analyzed in Example 5.5.1. Our goal will be to find a continuum analog of this problem allowing one to approximate both the minimal energy and the optimal microstructure. More specifically we search for the continuum problem which will be asymptotically Γ -equivalent to E_ε in the sense of [34]. In other words, the challenge is to construct a quasi-continuum problem still carrying some elements of the ‘lost’ discreteness of the original problem.

To show that the task of constructing such a problem is nontrivial we first present a naive approach to ‘continualization’ in this setting which has been proposed phenomenologically and studied extensively in applications [12]. We show the shortcomings of such an approach and then correct it to match the exact solution of the discrete problem presented in Section 5.5.

6.1 Naive construction

We recall that the original problem is defined on a bounded interval I and involves two functions $u, v \in \mathcal{A}_\varepsilon(I)$. We can write the corresponding energy function in the form of a sum

$$E_\varepsilon(u, v; I) = E_\varepsilon^*(u; I) + E_\varepsilon^{**}(u, v; I) \quad (6.1)$$

where

$$E_\varepsilon^*(u; I) = \varepsilon \sum_{i \in \mathcal{I}_\varepsilon^*(I)} f\left(\frac{u_i - u_{i-1}}{\varepsilon}\right) \quad (6.2)$$

with $\mathcal{I}_\varepsilon^* = \{i \in \mathbb{Z} : \varepsilon i, \varepsilon(i-1) \in I\}$ and

$$E_\varepsilon^{**}(u, v; I) = \frac{a}{\varepsilon} \sum_{i \in \mathcal{I}_\varepsilon^*(I)} (v_i - v_{i-1})^2 + \frac{b}{\varepsilon} \sum_{i \in \mathcal{I}_\varepsilon(I)} (u_i - v_i)^2, \quad (6.3)$$

Assuming now that I is a bounded interval and $\varepsilon > 0$, we can construct for each of the entries in the sum (6.1), viewed *independently*, the asymptotically Γ -equivalent functionals, defined, respectively, for $u \in SBV(I)$ and $v \in H^1(I)$. This equivalence can be interpreted as a uniform (with respect to boundary data) approximation up to order ε of problems with fixed boundary data for E_ε^* and E_ε^{**} by the corresponding problems for some functionals G_ε^* and G_ε^{**} , respectively.

A natural choice for such *independently* equivalent functionals (see [34] for details) is

$$G_\varepsilon^*(u; I) = \int_I \gamma(u')^2 dt + \eta \varepsilon \#S(u), \quad (6.4)$$

and

$$G_\varepsilon^{**}(u, v; I) = \int_I \left(\alpha(v')^2 + \beta \left(\frac{u-v}{\varepsilon} \right)^2 \right) dt \quad (6.5)$$

for suitable $\alpha, \beta, \gamma, \eta > 0$. We recall that here u is a piecewise-Sobolev function with jump set denoted by $S(u)$. Given (6.4) and (6.5) it seems natural to assume that the functional

$$G_\varepsilon(u, v; I) = \int_I \left(\gamma(u')^2 + \alpha(v')^2 + \beta \left(\frac{u-v}{\varepsilon} \right)^2 \right) dt + \eta \varepsilon \#S(u) \quad (6.6)$$

represents the desired (quasi) continuum analog of the original problem.

We recall the convergence result proved in [24].

Remark 6.1 (asymptotic behaviour of the energies G_ε). The Γ -limit of G_ε with respect to the convergence $u_\varepsilon, v_\varepsilon \rightarrow v$ in $L^2(I)$ is given by

$$G_{\text{hom}}(v) = \int_I g_{\text{hom}}(v') dt.$$

The integrand g_{hom} is characterized as

$$g_{\text{hom}}(z) = \inf_{S>0} \left\{ \lambda_S z^2 + \frac{\eta}{S} \right\} \quad (6.7)$$

where

$$\lambda_S = \frac{(\alpha + \gamma) \frac{\omega S}{2}}{\frac{\omega S}{2} + \frac{\gamma}{\alpha} \tanh(\frac{\omega S}{2})} \quad \text{and} \quad \omega^2 = \frac{(\alpha + \gamma)\beta}{\alpha\gamma}. \quad (6.8)$$

The function $g_{\text{hom}}(z)$ is strictly convex, and the following properties hold:

- (i) $g_{\text{hom}}(z) = (\alpha + \gamma)z^2$ in $[0, z_c]$, where $z_c = \sqrt{\frac{2\eta\omega\alpha}{4\gamma(\alpha+\gamma)}}$;
- (ii) $g_{\text{hom}}(z) \sim \alpha z^2 + Cz^{2/3}$ as $z \rightarrow +\infty$, where $C > 0$ depends only on $\alpha, \beta, \gamma, \eta$.

6.2 Lattice induced interdependence of $E_\varepsilon^*(u; I)$ and $E_\varepsilon^{**}(u, v; I)$

Now we show that using the above approach, we obtain the discontinuous function u which provides only formal approximations for the ‘jump sets’ of the original discrete problems.

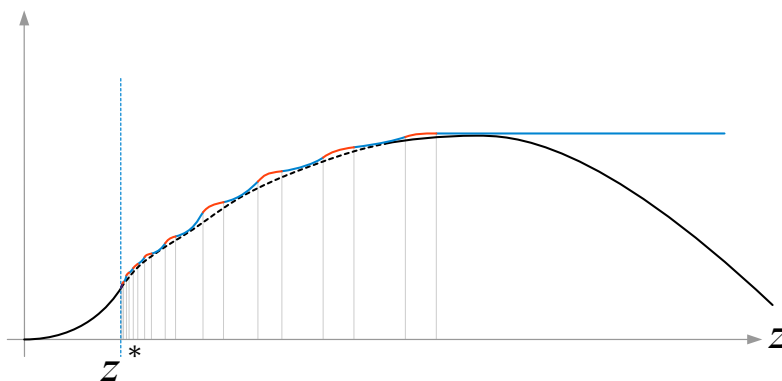

Figure 31: comparison between the graph of the function g_{hom} (below) and that of $Q_{\mathbf{m}}f$ after subtraction of the quadratic part

Remark 6.2 (non-equivalent scaling behavior). Note first that the critical value \bar{z}_* in the NT discrete model, defined in (5.59), is different from the corresponding critical value in the continuum problem discussed above. Indeed, if we choose $\gamma = 1$ as in the discrete case, in order for the discrete and continuous energies to be equivalent up to \bar{z}_* we need to ‘correct’ the continuum fracture energy by substituting η with an *effective fracture toughness* $\frac{\eta}{\cosh \zeta}$ with ζ given by (5.55). However, such a correction will not extend the equality of the energy functions beyond the threshold. In particular, note the different scaling behavior of the two models as z diverges, see Fig. 31.

It is clear that the proposed *lattice-independent* approximation of $E_\varepsilon^*(u; I)$ and $E_\varepsilon^{**}(u, v; I)$ fails because in general separate uniform approximations of minima for two functionals does not provide a uniform approximation for the minimum of the sum. More specifically, in our case functionals G_ε^* favor the onset of (at most) one jump point of u , while functionals G_ε^{**} , not involving jump sets, allow for an unbounded number of jumps. While in the correspondingly tailored regimes we can have good *separate* approximations, the sum of the two energies in E_ε optimizes the number and location of jumps accounting for the lattice induced interaction between $E_\varepsilon^*(u; I)$ and $E_\varepsilon^{**}(u, v; I)$ and therefore in a different way than G_ε which does not account for such lattice induced interaction.

Note that while in the discrete case we have interaction constrained by the lattice discreteness, in the naive continuum problem such interaction is lattice-unconstrained, which allows in principle for a richer class of microstructures. That is why we can obtain in this way at most a lower bound.

6.3 A lattice-compatible construction

As we have seen above, the limit of the energies defined in (6.4) when $\varepsilon \rightarrow 0$ has different properties from those of its discrete counterpart and the failure of this approach is related to the discrete-to-continuum transition-induced loss of the constraint on the location of the jumps.

To construct the asymptotically equivalent [34] continuum theory the approach should be more subtle because the corresponding relaxation procedure should involve a delicate interplay between continuum limit and discrete energy minimization, which are tightly coupled.

Indeed, as we have seen above decoupling discrete-to-continuum transition from the relaxation of a non-convex energy gives rise to a quantitatively and qualitatively incorrect asymptotic behavior. Apparently the discrete-to-continuum limit and the incompatibility-constrained non-convex minimization do not commute and by performing the former independently of the latter we at best underestimate the relaxed energy. In other words, by neglecting the discrete constraint we may be able to construct lower bounds (using the naive approximation). We do not systematically analyze this issue here.

To get an insight on how to fix the problem, it is instructive to compare (6.7) with formulas (5.56) and (5.57). Note, in particular, that in the latter the parameter N is discrete while in the former the parameter S is continuous. This highlights that the discreteness, fundamental

in the construction of the \mathbf{m} -relaxation in the original problem, is underestimated in the computation of g_{hom} . In other words, the internal physical scale and the lattice scale tend to zero simultaneously but the value of their ratio is not remembered in the limit.

With this remark in mind, we now look for a modification of the ‘naive’ continuum energies which corrects the non-equivalent behavior, while maintaining the relevant features associated with the discreteness in the original functional E_ε . Since the energies defined in (6.4) cannot be equivalent to E_ε mainly because of the discrete location of the jump points, it is natural to add the constraint that the jump set $S(u)$ be contained in $\varepsilon\mathbb{Z}$.

As we show below, this simple modification is indeed sufficient to obtain equivalence. Here we imply that the energies depending on three parameters α , β and γ (instead of a , b and 1, respectively), can be tuned appropriately to construct the correct limiting energy.

More specifically, for any $\varepsilon > 0$ we define for $u \in SBV(I)$ and $v \in H^1(I)$ the functional

$$G_\varepsilon^{\mathbb{Z}}(u, v; I) = \begin{cases} G_\varepsilon(u, v; I) & \text{if } S(u) \subset \varepsilon\mathbb{Z} \\ +\infty & \text{otherwise.} \end{cases} \quad (6.9)$$

By the general homogenization theorem [24, Th. 3] we get the following Γ -convergence result.

Proposition 6.3. *The sequence $G_\varepsilon^{\mathbb{Z}}(u, v; I)$ Γ -converges with respect to the convergence $u_\varepsilon, v_\varepsilon \rightarrow v$ in $L^2(I)$ to*

$$G_{\text{hom}}^{\mathbb{Z}}(v) = \int_I g_{\text{hom}}^{\mathbb{Z}}(v') dt \quad (6.10)$$

where

$$g_{\text{hom}}^{\mathbb{Z}}(z) = \lim_{N \rightarrow +\infty} \frac{1}{N} \inf\{G_1^{\mathbb{Z}}(u, v; (0, N)) : u(0) = v(0) = 0, u(N) = v(N) = Nz\}. \quad (6.11)$$

The proof of Proposition 6.3 can be obtained by following the steps of the proof of [24, Theorem 3]. Indeed, in the blow-up procedure the jump set $S(u_\varepsilon)$ is not modified, and the liminf inequality follows. Concerning the upper estimate, by density we can consider a piecewise-affine target function v such that $S(v') \subset \mathbb{Q}$; then, the construction of the recovery sequence can be done by following the same steps as in the proof of [24, Theorem 3], and the scaling argument gives u_ε such that $S(u_\varepsilon) \subset \varepsilon\mathbb{Z}$. Note that the function $g_{\text{hom}}^{\mathbb{Z}}$ is convex.

Now we will show that the sequence $G_\varepsilon^{\mathbb{Z}}(u, v; I)$ has the same Γ -limit as the discrete sequence E_ε for a suitable choice of the parameters α, β, γ . We define

$$g(N, z) = \frac{1}{N} \min\{\tilde{G}_1(u, v; (0, N)) : u, v \in H^1(0, N), v(0) = 0, v(N) = Nz\}, \quad (6.12)$$

where, in analogy with (5.29), we denote by \tilde{G}_1 the (non scaled) functional given by

$$\tilde{G}_1(u, v; I) = \int_I \left(\gamma(u')^2 + \alpha(v')^2 + \beta(u - v)^2 \right) dt.$$

By solving the Euler-Lagrange equations for \tilde{G}_1 and minimizing on the boundary values of u , it follows that

$$g(N, z) = \lambda_N z^2 \quad (6.13)$$

with λ_N defined in (6.8). Note that the (unique) solution (u_N, v_N) of the minimum problem defining $g(N, z)$ satisfies the symmetry property $u(\frac{N}{2}) = v(\frac{N}{2}) = \frac{N}{2}z$.

Proposition 6.4. *For any $z \in \mathbb{R}$ the following equality holds:*

$$g_{\text{hom}}^{\mathbb{Z}}(z) = \left(\inf_{N \in \mathbb{N}} \left\{ \lambda_N z^2 + \frac{\eta}{N} \right\} \right)^{**}. \quad (6.14)$$

Proof. We fix $z \in \mathbb{R}$ and $N \in \mathbb{N}$; let (u_N, v_N) be the solution of the minimum problem defining $\psi(N, z)$. We define $\tilde{u}_N \in SBV(0, 2N)$ by setting

$$\tilde{u}_N(t) = \begin{cases} 2u_N(\frac{t+N}{2}) - Nz & \text{if } t \in (0, N) \\ 2u_N(\frac{t-N}{2}) + Nz & \text{if } t \in (N, 2N) \end{cases} \quad (6.15)$$

and correspondingly $\tilde{v}_N \in H^1(0, 2N)$. Since $u_N(\frac{N}{2}) = v_N(\frac{N}{2}) = \frac{N}{2}z$, then $S(\tilde{u}_N) = \{N\}$, $\tilde{u}_N(0) = \tilde{v}_N(0) = 0$ and $\tilde{u}_N(2N) = \tilde{v}_N(2N) = 2Nz$; by construction

$$\frac{1}{2N} \tilde{G}_1(\tilde{u}_N, \tilde{v}_N; (0, 2N)) = \frac{1}{N} \tilde{G}_1(u_N, v_N; (0, N)) = \lambda_N z^2.$$

Let $k \in \mathbb{N}$. We define \tilde{u} in $(0, 2kN)$ by setting

$$\tilde{u}(t) = \tilde{u}_N(t - 2jN) + 2jNz \quad \text{in } (2jN, 2(j+1)N), \quad j = 0, \dots, k-1$$

and in the same way we define \tilde{v} . By construction, $S(\tilde{u}) \subset \mathbb{N}$ and $\#S(\tilde{u}) = k-1$; hence, since the boundary conditions for \tilde{u} and \tilde{v} hold, we have

$$\begin{aligned} \lambda_N z^2 + \frac{\eta}{N} &= \frac{1}{2kN} \tilde{G}_1(\tilde{u}, \tilde{v}; (0, 2kN)) + \frac{\eta(k-1)}{kN} + \frac{\eta}{kN} \\ &= \frac{1}{2kN} G_1^{\mathbb{Z}}(\tilde{u}, \tilde{v}; (0, 2kN)) + \frac{\eta}{kN} \\ &\geq \frac{1}{2kN} \inf \left\{ G_1^{\mathbb{Z}}(u, v; (0, 2kN)) : \right. \\ &\quad \left. u(0) = v(0) = 0, u(kN) = v(kN) = 2kNz \right\} + \frac{\eta}{kN}, \end{aligned}$$

and, by taking the limit as $k \rightarrow +\infty$,

$$\lambda_N z^2 + \frac{\eta}{N} \geq g_{\text{hom}}^{\mathbb{Z}}(z).$$

Hence, since $g_{\text{hom}}^{\mathbb{Z}}$ is convex,

$$\left(\inf_{N \in \mathbb{N}} \left\{ \lambda_N z^2 + \frac{\eta}{N} \right\} \right)^{**} \geq g_{\text{hom}}^{\mathbb{Z}}(z).$$

Next we need to prove the opposite inequality. Let $u \in SBV(0, N)$ and $v \in H^1(0, N)$ be such that the boundary conditions $u(0) = v(0) = 0$, $u(N) = v(N) = Nz$ hold and $S(u) \subset \mathbb{N}$. We denote the jump points of u by N_i , $i = 1, \dots, k$, with $N_i < N_{i+1}$ for any $i = 1, \dots, k-1$. Setting $N_0 = 0$ and $N_{k+1} = N$, we define

$$n_i = N_i - N_{i-1} \quad \text{and} \quad z_i = \frac{v(N_i) - v(N_{i-1})}{n_i}$$

for $i = 1, \dots, k+1$. We then have

$$\frac{1}{n_i} \tilde{G}_1(u, v; (N_{i-1}, N_i)) \geq g(n_i, z_i) = \lambda_{n_i} z_i^2$$

for any i , so that

$$\begin{aligned} \frac{1}{N} G_1^{\mathbb{Z}}(u, v; (0, N)) &\geq \sum_{i=1}^{k+1} \frac{n_i}{N} \lambda_{n_i} z_i^2 + \frac{\eta k}{N} = \sum_{i=1}^{k+1} \frac{n_i}{N} \left(\lambda_{n_i} z_i^2 + \frac{\eta}{n_i} \right) \\ &\geq \sum_{i=1}^{k+1} \frac{n_i}{N} \inf_{n \in \mathbb{N}} \left\{ \lambda_n z_i^2 + \frac{\eta}{n} \right\} \end{aligned}$$

Since $\sum_{i=1}^{k+1} n_i = N$ and $\sum_{i=1}^{k+1} n_i z_i = Nz$, an application of Carathéodory's Theorem gives

$$\frac{1}{N} G_1^{\mathbb{Z}}(u, v; (0, N)) \geq \left(\inf_{n \in \mathbb{N}} \left\{ \lambda_n z^2 + \frac{\eta}{n} \right\} \right)^{**}.$$

Taking the inf over the admissible functions and the limit for $N \rightarrow +\infty$ we get the inequality

$$g_{\text{hom}}^{\mathbb{Z}}(z) \geq \left(\inf_{n \in \mathbb{N}} \left\{ \lambda_n z^2 + \frac{\eta}{n} \right\} \right)^{**}$$

concluding the proof. \square

Now, if we choose

$$\alpha = \frac{a(a+1)}{a + \zeta \coth(\zeta)}, \quad \beta = \frac{4a(a+1)\zeta^3 \coth(\zeta)}{(a + \zeta \coth(\zeta))^2}, \quad \gamma = \frac{(a+1)\zeta \coth(\zeta)}{a + \zeta \coth(\zeta)} \quad (6.16)$$

it follows that $\omega = 2\zeta$, where ζ is defined in (5.55), and for any N the following equality holds

$$\lambda_N = c_N = \frac{N(a+1)a}{aN + \tanh(N\zeta) \coth(\zeta)}.$$

We can then state the following equivalence result, whose proof follows from the equivalence between E_ε and F_ε (Theorem 5.6 and Remark 5.8) and the results above.

Theorem 6.5 (equivalence with the Novak-Truskinovsky model). *Choosing the coefficients as in (6.16), the sequence $G_\varepsilon^{\mathbb{Z}}$ defined in (6.9) Γ -converges with respect to the L^2 -convergence to the same Γ -limit of the sequence of discrete functionals E_ε in the truncated quadratic case.*

We reiterate that in general, the above result can be viewed as a cautionary tale, showing that relaxation and homogenization (discrete-to-continuum limit) do not always commute.

7 Conclusions

In this paper, we systematically explored the possibility of using some auxiliary ‘local’ considerations to obtain minimizers with ‘global’ features for nonlocal variational boundary-value problems on lattices. Having in mind some known cases when asymptotically (i.e. in continuum limit) such boundary-value problems exhibit periodic minimizers, we associated the possibility of ‘local’ description with applicability of the GCB rule and posed the question of the pertinence of such a rule for a generic variational problem in our class. It is clear that the GCB rule is not applicable in general, for instance, it clearly fails in the case of minimization with concentrations, appearing in non-coercive problems of fracture mechanics. Here we extended the known class of non-GCB problems by incorporating into the analysis some general non-convex energy densities with quadratic growth.

More specifically, we used the simplest examples of functionals with quadratically penalized non-convexity, we demonstrated various facets of frustration and incompatibility in one-dimensional discrete variational problems computed on an increasing and diverging number of nodes. In the chosen class of non-convex lattice problems with energy density f , linear long-range interactions were introduced through an infinite matrix \mathbf{m} . We studied relaxation of such problems with given boundary conditions on intervals with a large number of nodes. This operation can be interpreted as a discrete-to-continuum \mathbf{m} -transform of the function f and we studied the dependence of such a transform on the parameter z describing boundary conditions.

We addressed the question whether the minimizers for a given functional are close to functions with ‘global’ properties, for instance, to periodic functions, where closeness can be understood as having the same energy up to an asymptotically negligible quantity as the number of nodes diverges. The answer is in general negative, for example, this is not true in the case of minimizers describing transitions between two energy wells, when the parameter z lies in some intervals. Still, we were able to identify interesting cases when the knowledge of the minimizers, that are asymptotically of a ‘global’ form, are sufficient to determine the whole \mathbf{m} -transform of the function f through some form of convexification.

Outside our general considerations, we mostly focused on potentials f with a bi-convex form; i.e., which have a convex restriction to two complementary phase sets. For boundary-value problems involving such potentials and prescribed z it is natural to define phase functions $\theta(z)$. We have shown that of particular interest are values of θ for which the set $\{z : \theta(z) = \theta\}$ contains a non-degenerate interval (locking states). We studied the main properties of both,

the functions $\theta(z)$ and of locking states, and showed that for some combinations of f and \mathbf{m} the minimizers representing the locking states are periodic and hence of a ‘global’ (or GCB) nature in the sense that they determine the whole \mathbf{m} -transform of the function f . We also showed that the optimal periodic minimizers whose structure may depend delicately on f and \mathbf{m} are not necessarily unique. Among different optimal minimizers we identified universal periodic microstructures, which exist for all values of θ and have fascinating analogs in the theory of dynamical systems (see [9] and a mechanical analog in [84]).

The concept of \mathbf{m} -transform, introduced in this paper for the first time, was shown to be rather rich. The complexity of the ensuing transformations suggests that even in scalar one-dimensional problems, the interplay of long-range interactions, non-convexity and discreteness can be highly nontrivial. We presented several examples where the \mathbf{m} -transform of a given non-convex function could be either computed explicitly or narrowly bounded. Some of the obtained \mathbf{m} -transforms were shown to be singular exhibiting the ‘devilish’ features with locking on some but not all *rational* microstructures.

The analytical accessibility of the \mathbf{m} -transforms in the presented examples, as well as the associated non-uniqueness of the optimal micro-structures, hint towards a certain *degeneracy* of the chosen problems. We can associate such a degeneracy with the absence of ‘strong’ geometrical frustration representing some fundamental incommensurability between the non-convexity, the long range interactions and the discreteness. It is clear that more complex optimal minimizing sequences, not reducible to periodic states or combinations of periodic states, can be expected in cases when such incommensurability is present.

The ‘strong’ frustration of this type may be driven, for instance, by the competing interactions inside the kernel \mathbf{m} , for instance, by the combination of ferromagnetic and antiferromagnetic interactions acting on incommensurate scales. The frustration can be also ‘strong’ even in the apparently simple case when different scales are ‘favored’ by antiferromagnetic interaction involving the first and the third nearest neighbors. ‘Strong’ frustration may also be brought by the structure of the non-convex function f carrying the ‘characteristic strain’ which is incompatible with the strain emerging through the interplay between the loading and the long-range interaction kernel, see for instance [84] where a ‘complete devil staircase’ emerges in a problem involving a non-degenerate bi-quadratic potential and an exponential kernel.

In a separate paper we will show that the presence of ‘strong’ frustration may eliminate the degeneracy and bring the uniqueness to the problem of finding the optimal microstructure. More generally, our preliminary analysis of problems with ‘strong’ frustration reveals an even deeper link between lattice variational problem and the discrete nonlinear mappings where the analog of constructing the \mathbf{m} -transform turns out to be the problem of classifying all quasi-periodic trajectories.

Acknowledgments

AC and MS acknowledge the projects ‘Fondo di Ateneo per la Ricerca 2019’ and ‘Fondo di Ateneo per la Ricerca 2020’, funded by the University of Sassari. This work has been supported by PRIN 2017 ‘Variational methods for stationary and evolution problems with singularities and interfaces’. AB and MS are members of GNAMPA, INdAM, AC is member of GNSAGA, INdAM. The authors acknowledge the MIUR Excellence Department Project awarded to the Department of Mathematics, University of Rome Tor Vergata, CUP E83C18000100006. The work of LT was supported by the grant ANR-10-IDEX-0001-02 PSL.

A Appendix: variations of boundary data

In this appendix we state and prove some technical results which allow the modification of boundary values of test functions for the minimum problems used in various characterization of $Q_{\mathbf{m}}f$. In particular, these results allow to assume that test functions be constant close to the endpoints of the domain.

Let $\mathbf{m} = \{m_n\}_n$ be such that $m_n \geq 0$ for any n , and there exists \bar{n} such that m_n is not increasing for $n \geq \bar{n}$. Moreover, we assume the decay condition $m_n = o(n^{-\beta})_{n \rightarrow +\infty}$ for some $\beta > 2$.

Let F_ε be defined as in (2.8); that is,

$$F_\varepsilon(u; I) = \sum_{\varepsilon i, \varepsilon(i-1) \in I} \varepsilon f\left(\frac{u_i - u_{i-1}}{\varepsilon}\right) + \sum_{\varepsilon i, \varepsilon j \in I} \varepsilon m_{|i-j|} \left(\frac{u_i - u_j}{\varepsilon}\right)^2$$

for I interval and $u \in \mathcal{A}_\varepsilon(I)$.

Lemma A.1. *Let $L > 0$ and $N_\varepsilon = \lfloor \frac{L}{\varepsilon} \rfloor$. Let $\alpha \in (\frac{2}{\beta}, 1)$. Assume that $u \in L^2(0, L)$ and $u^\varepsilon \in \mathcal{A}_\varepsilon = \mathcal{A}_\varepsilon(0, L)$ be such that (the piecewise-affine extension of) the sequence u^ε converges to u in $L^2(0, L)$, and $\sup_\varepsilon (F_\varepsilon(u^\varepsilon; [0, L]) + \|u^\varepsilon\|_{L^2}^2) = S < +\infty$. Then, there exists $\hat{u}^\varepsilon \in \mathcal{A}_\varepsilon$ converging to u such that*

- (i) $\hat{u}_i^\varepsilon = \hat{u}_0^\varepsilon$ for $i \leq \varepsilon^{-\alpha}$, $\hat{u}_i^\varepsilon = \hat{u}_{N_\varepsilon}^\varepsilon$ for $i \geq N_\varepsilon - \varepsilon^{-\alpha}$;
- (ii) $F_\varepsilon(\hat{u}^\varepsilon; [0, L]) \leq F_\varepsilon(u^\varepsilon; [0, L]) + r(\varepsilon)$, where the remainder r depends only on S and $f(0)$, and $r(\varepsilon) \rightarrow 0$ as $\varepsilon \rightarrow 0$.

Proof. We choose $\alpha' \in (0, 1 - \alpha)$ and define $\lambda_\varepsilon = \varepsilon^{\alpha'}$ and $M_\varepsilon = \lfloor \varepsilon^{\alpha + \alpha' - 1} \rfloor - 1$. For ε small enough we divide $(0, \lambda_\varepsilon]$ and $[L - \lambda_\varepsilon, L)$ in $M_\varepsilon + 1$ intervals by setting

$$I_\varepsilon^k = \left(\frac{k\lambda_\varepsilon}{M_\varepsilon + 1}, \frac{(k+1)\lambda_\varepsilon}{M_\varepsilon + 1} \right], \quad J_\varepsilon^k = \left[L - \frac{(k+1)\lambda_\varepsilon}{M_\varepsilon + 1}, L - \frac{k\lambda_\varepsilon}{M_\varepsilon + 1} \right), \quad k \in \{0, \dots, M_\varepsilon\}.$$

Since

$$\frac{1}{\varepsilon} \sum_{k=1}^{M_\varepsilon} \sum_{\varepsilon i \in I_\varepsilon^k, \varepsilon j \in I_\varepsilon^{k-1}} m_{|i-j|} (u_i^\varepsilon - u_j^\varepsilon)^2 \leq F_\varepsilon(u^\varepsilon; [0, L]) \leq S,$$

then there exists $k_\varepsilon^- \in \{1, \dots, M_\varepsilon\}$ such that

$$\frac{1}{\varepsilon} \sum_{\varepsilon i \in I_\varepsilon^{k_\varepsilon^-}, \varepsilon j \in I_\varepsilon^{k_\varepsilon^- - 1}} m_{|i-j|} (u_i^\varepsilon - u_j^\varepsilon)^2 \leq \frac{S}{M_\varepsilon}. \quad (\text{A.1})$$

The same argument allows to find $k_\varepsilon^+ \in \{1, \dots, M_\varepsilon\}$ such that the same inequality holds for $\varepsilon i \in J_\varepsilon^{k_\varepsilon^+}, \varepsilon j \in J_\varepsilon^{k_\varepsilon^+ - 1}$. Setting $j_\varepsilon^- = \min\{j : \varepsilon j \in I_\varepsilon^{k_\varepsilon^-}\}$ and $j_\varepsilon^+ = \max\{j : \varepsilon j \in J_\varepsilon^{k_\varepsilon^+}\}$, we define \hat{u}^ε by setting

$$\hat{u}_i^\varepsilon = \begin{cases} u_{j_\varepsilon^-}^\varepsilon & \text{if } i \leq j_\varepsilon^- \\ u_i^\varepsilon & \text{if } j_\varepsilon^- \leq i \leq j_\varepsilon^+ \\ u_{j_\varepsilon^+}^\varepsilon & \text{if } i \geq j_\varepsilon^+. \end{cases} \quad (\text{A.2})$$

Since $j_\varepsilon^- \geq L\varepsilon^{-\alpha}$ and $j_\varepsilon^+ \leq N_\varepsilon - L\varepsilon^{-\alpha}$, then \hat{u}^ε satisfies claim (i). Moreover, $\hat{u}^\varepsilon \rightarrow u$ as $\varepsilon \rightarrow 0$. To prove this, for simplicity we suppose that m_n is not increasing for $n \geq 1$. Then,

$$\begin{aligned} \varepsilon \sum_{i=1}^{j_\varepsilon^-} (u_i^\varepsilon - \hat{u}_i^\varepsilon)^2 &= \varepsilon \sum_{i=1}^{j_\varepsilon^-} (u_i^\varepsilon - u_{j_\varepsilon^-}^\varepsilon)^2 \leq \varepsilon \sum_{i=1}^{j_\varepsilon^-} j_\varepsilon^- \sum_{j=i+1}^{j_\varepsilon^-} (u_i^\varepsilon - u_{i-1}^\varepsilon)^2 \\ &\leq \frac{S}{m_1} \varepsilon^2 (j_\varepsilon^-)^2 \leq \frac{S}{m_1} \lambda_\varepsilon^2, \end{aligned}$$

and correspondingly $\varepsilon \sum_{i=j_\varepsilon^+}^{\lfloor L/\varepsilon \rfloor} (u_i^\varepsilon - \hat{u}_i^\varepsilon)^2 \leq \frac{S}{m_1} \lambda_\varepsilon^2$. Setting, $n_\varepsilon = \lfloor \frac{\lambda_\varepsilon}{\varepsilon(M_\varepsilon+1)} \rfloor$, since

$$\sum_{|i-j| \geq n_\varepsilon} m_{|i-j|} (u_i^\varepsilon - u_j^\varepsilon)^2 \leq \frac{2}{\varepsilon} m_{n_\varepsilon} \|u^\varepsilon\|_{L^2}^2 \leq \frac{2}{\varepsilon} m_{\lfloor \varepsilon^{-\alpha} \rfloor} \|u^\varepsilon\|_{L^2}^2,$$

and recalling (A.1), we obtain

$$F_\varepsilon(\hat{u}^\varepsilon; [0, L]) \leq F_\varepsilon(u^\varepsilon; [0, L]) + 2\lambda_\varepsilon f(0) + \frac{C}{\varepsilon^2} m_{\lfloor \varepsilon^{-\alpha} \rfloor} + \frac{C}{M_\varepsilon},$$

where C denotes a constant depending only on $\sup_\varepsilon F_\varepsilon(u^\varepsilon; [0, L])$ and $\sup_\varepsilon \|u^\varepsilon\|_{L^2}$. Setting

$$r(t) = 2f(0)t^{\alpha'} + Ct^{\alpha\beta-2} + Ct^{1-\alpha-\alpha'},$$

we conclude the proof since $m_n = o(n^{-\beta})$ and $\alpha > \frac{2}{\beta}$. \square

Let $a, b > 0$. We define the functional $E_\varepsilon(u, v; I)$ by setting

$$E_\varepsilon(u, v; I) = \sum_{\varepsilon i, \varepsilon(i-i) \in I} \varepsilon f\left(\frac{u_i - u_{i-1}}{\varepsilon}\right) + \frac{a}{2} \sum_{\varepsilon i, \varepsilon(i-i) \in I} \varepsilon \left(\frac{v_i - v_{i-1}}{\varepsilon}\right)^2 + \frac{b}{2\varepsilon} \sum_{\varepsilon i \in I} (u_i - v_i)^2 \quad (\text{A.3})$$

for I interval and $u, v \in \mathcal{A}_\varepsilon(I)$.

Lemma A.2. *Let $L > 0$ and $N_\varepsilon = \lfloor \frac{L}{\varepsilon} \rfloor$. Let $\alpha \in (\frac{2}{\beta}, 1)$. Assume that $u^\varepsilon, v^\varepsilon \in \mathcal{A}_\varepsilon$ be such that (the piecewise-affine extensions of) u^ε and v^ε converge to u in $L^2(0, L)$ and $\sup_\varepsilon (E_\varepsilon(u^\varepsilon; [0, L]) + \|u^\varepsilon\|_{L^2}^2) = S < +\infty$. Then there exist $\hat{u}^\varepsilon, \hat{v}^\varepsilon \in \mathcal{A}_\varepsilon$ converging to u such that*

- (i) $\hat{u}_i^\varepsilon = \hat{v}_i^\varepsilon = \hat{u}_0^\varepsilon$ for $i \leq \varepsilon^{-\alpha}$, $\hat{u}_i^\varepsilon = \hat{v}_i^\varepsilon = \hat{u}_{N_\varepsilon}^\varepsilon$ for $i \geq N_\varepsilon - \varepsilon^{-\alpha}$;
- (ii) $E_\varepsilon(\hat{u}^\varepsilon, \hat{v}^\varepsilon; [0, L]) \leq E_\varepsilon(u^\varepsilon, v^\varepsilon; [0, L]) + r(\varepsilon)$, where the remainder r depends only on S and $f(0)$, and $r(\varepsilon) \rightarrow 0$ as $\varepsilon \rightarrow 0$.

Proof. We choose λ_ε and M_ε as in the proof of Lemma A.1, and divide $(0, \lambda_\varepsilon]$ and $[L - \lambda_\varepsilon, L)$ in $M_\varepsilon + 1$ intervals, denoted by I_ε^k and J_ε^k respectively, as above. Then, there exist k_ε and h_ε in $\{1, \dots, M_\varepsilon\}$ such that

$$\frac{1}{2\varepsilon} \sum_{\varepsilon i \in I_\varepsilon^{k_\varepsilon} \cup J_\varepsilon^{h_\varepsilon}} (a(v_i^\varepsilon - v_{i-1}^\varepsilon)^2 + b(u_i^\varepsilon - v_i^\varepsilon)^2) \leq \frac{S}{M_\varepsilon}. \quad (\text{A.4})$$

Setting $j_\varepsilon^- = \min\{j : \varepsilon j \in I_\varepsilon^{k_\varepsilon}\}$ and $j_\varepsilon^+ = \max\{j : \varepsilon j \in J_\varepsilon^{h_\varepsilon}\}$, we define

$$\hat{u}_i^\varepsilon = \begin{cases} u_{j_\varepsilon^-}^\varepsilon & \text{if } i \leq j_\varepsilon^- \\ u_i^\varepsilon & \text{if } j_\varepsilon^- < i < j_\varepsilon^+ \\ u_{j_\varepsilon^+}^\varepsilon & \text{if } i \geq j_\varepsilon^+ \end{cases} \quad \text{and} \quad \hat{v}_i^\varepsilon = \begin{cases} u_{j_\varepsilon^-}^\varepsilon & \text{if } i \leq j_\varepsilon^- \\ v_i^\varepsilon & \text{if } j_\varepsilon^- < i < j_\varepsilon^+ \\ u_{j_\varepsilon^+}^\varepsilon & \text{if } i \geq j_\varepsilon^+, \end{cases}$$

so that \hat{u}^ε and \hat{v}^ε converge to u in L^2 , and satisfy (i). Recalling (A.4), we get in particular that

$$\frac{a}{2\varepsilon} (\hat{v}_{j_\varepsilon^-+1}^\varepsilon - \hat{v}_{j_\varepsilon^-}^\varepsilon)^2 \leq \frac{a}{\varepsilon} (v_{j_\varepsilon^-+1}^\varepsilon - v_{j_\varepsilon^-}^\varepsilon)^2 + \frac{a}{\varepsilon} (v_{j_\varepsilon^-}^\varepsilon - u_{j_\varepsilon^-}^\varepsilon)^2 \leq \frac{C}{M_\varepsilon},$$

where C denotes a positive constant depending only on a, b and S . The same bound holds for $\frac{a}{2\varepsilon} (\hat{v}_{j_\varepsilon^+-1}^\varepsilon - \hat{v}_{j_\varepsilon^+}^\varepsilon)^2$. Hence

$$\begin{aligned} E_\varepsilon(\hat{u}_\varepsilon, \hat{v}_\varepsilon; [0, L]) &\leq 2\lambda_\varepsilon f(0) + E_\varepsilon(u^\varepsilon, v^\varepsilon; (0, L)) \\ &\quad + \frac{a}{2\varepsilon} (\hat{v}_{j_\varepsilon^-+1}^\varepsilon - \hat{v}_{j_\varepsilon^-}^\varepsilon)^2 + \frac{a}{2\varepsilon} (\hat{v}_{j_\varepsilon^+-1}^\varepsilon - \hat{v}_{j_\varepsilon^+}^\varepsilon)^2 \\ &\leq 2\lambda_\varepsilon f(0) + E_\varepsilon(u^\varepsilon, v^\varepsilon; [0, L]) + \frac{2C}{M_\varepsilon}, \end{aligned}$$

concluding the proof as above. \square

Remark A.3. In the hypotheses of Lemma A.2, if there exists $\alpha \in (0, 1)$ such that $u_i^\varepsilon = \hat{u}_0^\varepsilon$ for $i \leq \varepsilon^{-\alpha}$ and $u_i^\varepsilon = \hat{u}_{N_\varepsilon}^\varepsilon$ for $i \geq N_\varepsilon - \varepsilon^{-\alpha}$ for some $\alpha > 0$, then the function \hat{v}^ε can be chosen such that it coincides with u^ε for $i \leq \varepsilon^{-\alpha''}$ and for $i \geq N_\varepsilon - \varepsilon^{-\alpha''}$ with $\alpha'' < \alpha$.

B Appendix: formulas for $P^{M,n}$ in the concentrated case

In this appendix we include some explicit computations of the functions $P^{M,n}$ defined in (3.1), which are the energies of the locking states $\frac{n}{M}$ in the concentrated case. The formulas of these functions have been used in Sections 4.2.1 and 4.2.2 to highlight the structure of $Q_{\mathbf{m}}f(z)$ in the truncated-parabolic and double-well case, respectively. Here, we include the corresponding computations.

Truncated-parabolic case. Let f be given by (4.10). In view of (4.3), the domains of $P^{M,0}$ and $P^{M,M}$ are $\{z \leq 1\}$ and $\{z \geq 1\}$, respectively. We recall that here

$$P^{M,0}(z) = z^2 + 2(m_1 + m_M M^2)z^2 \quad \text{and} \quad P^{M,M}(z) = 1 + 2(m_1 + m_M M^2)z^2.$$

For $n = 1, \dots, M-1$, we can also write

$$P^{M,n}(z) = \begin{cases} \frac{2m_1 + 1}{1 - \theta_n} (z^2 - \theta_n(2z - 1)) + 2m_M M^2 z^2 & \text{if } z \leq T_n^- \\ \theta_n + \frac{2m_1(2m_1 + 1)}{2m_1 + \theta_n} z^2 + 2m_M M^2 z^2 & \text{if } T_n^- \leq z \leq T_n^+ \\ 1 + \frac{2m_1}{\theta_n} ((z - 1)^2 + \theta_n(2z - 1)) + 2m_M M^2 z^2 & \text{if } z \geq T_n^+, \end{cases} \quad (\text{B.1})$$

where

$$T_n^- = \frac{2m_1 + \theta_n}{2m_1 + 1} \quad \text{and} \quad T_n^+ = \frac{2m_1 + \theta_n}{2m_1}.$$

Note that while the formula defining $P^{M,n}$ changes form at $z = T_n^-$ and $z = T_n^+$, the computation of the common tangent points of $P^{M,n}$ and $P^{M,n+1}$ involves only the central formula in (B.1). Consequently, the points s_n^+ and s_n^- in Theorem 4.1 are

$$\begin{aligned} s_n^+ &= s_n^+(m_1, m_M) = \frac{2m_1 + \theta_n}{\sqrt{2m_1(2m_1 + 1)}} \sqrt{\frac{m_1(2m_1 + 1) + m_M M^2(2m_1 + \theta_{n+1})}{m_1(2m_1 + 1) + m_M M^2(2m_1 + \theta_n)}} \\ s_n^- &= s_n^-(m_1, m_M) = \frac{2m_1 + \theta_n}{\sqrt{2m_1(2m_1 + 1)}} \sqrt{\frac{m_1(2m_1 + 1) + m_M M^2(2m_1 + \theta_{n-1})}{m_1(2m_1 + 1) + m_M M^2(2m_1 + \theta_n)}}. \end{aligned} \quad (\text{B.2})$$

In Fig. 32 we illustrate the envelope of two consecutive functions $P^{M,n}(z)$, bridging energies of consecutive locking states with an affine function.

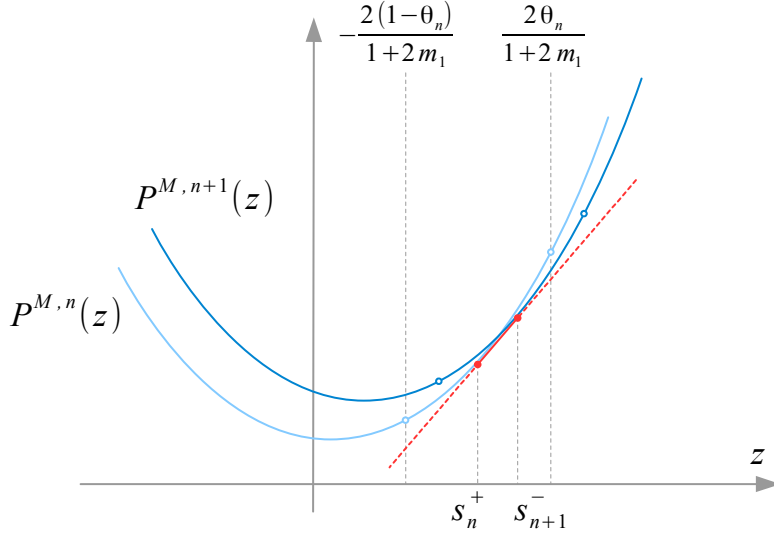

Figure 32: Envelope of two consecutive functions $P^{M,n}(z)$

Finally, since $s_n^+ \geq T_n^-$ and $s_n^- \leq T_n^+$, we have the following formula

$$Q_{\mathbf{m}}f(z) = \begin{cases} z^2 & \text{if } z \leq s_0^+ \\ r^{M,n}(z) - 2(m_1 + m_M M^2)z^2 & \text{if } s_n^+ \leq z \leq s_{n+1}^- \\ \frac{2m_1(1-\theta_n)}{2m_1 + \theta_n}z^2 + \theta_n & \text{if } s_n^- \leq z \leq s_n^+ \\ 1 & \text{if } s_M^- \leq z, \end{cases} \quad (\text{B.3})$$

where $r^{M,n}$ is the affine function

$$r^{M,n}(z) = P^{M,n}(s_n^+) + \frac{2(z - s_n^+)}{M(s_{n+1}^- - s_n^+)}.$$

Bi-quadratic double-well case. Let f be given by $f(z) = (1 - |z|)^2$. By using (4.3) the domains of $P^{M,0}$ and $P^{M,M}$ are $\{z \leq 0\}$ and $\{z \geq 0\}$, respectively, where

$$P^{M,0}(z) = (1 + z)^2 + 2(m_1 + m_M M^2)z^2 \quad \text{and} \quad P^{M,M}(z) = (1 - z)^2 + 2(m_1 + m_M M^2)z^2.$$

For $n = 1, \dots, M - 1$

$$P^{M,n}(z) = \begin{cases} \left(\frac{1+2m_1}{1-\theta_n} + 2m_M M^2\right)z^2 + 2z + 1 & \text{if } z \leq T_n^- \\ (1+z)^2 + 2(m_1 + m_M M^2)z^2 - 4\theta_n \left(z + \frac{1-\theta_n}{1+2m_1}\right) & \text{if } T_n^- \leq z \leq T_n^+ \\ \left(\frac{1+2m_1}{\theta_n} + 2m_M M^2\right)z^2 - 2z + 1 & \text{if } z \geq T_n^+, \end{cases}$$

where in this case the points T_n^- and T_n^+ where the formula changes are given by

$$T_n^- = -\frac{2(1-\theta_n)}{1+2m_1} \quad \text{and} \quad T_n^+ = \frac{2\theta_n}{1+2m_1}.$$

Consequently,

$$\begin{aligned} s_n^+(m_1, m_M) &= s_n^+ = \frac{2m_M M}{(1+2m_1)(1+2m_1+2m_M M^2)} + \frac{2\theta_n - 1}{1+2m_1} \\ s_n^-(m_1, m_M) &= s_n^- = -\frac{2m_M M}{(1+2m_1)(1+2m_1+2m_M M^2)} + \frac{2\theta_n - 1}{1+2m_1}. \end{aligned} \quad (\text{B.4})$$

Since $s_n^+ \geq T_n^-$ and $s_n^- \leq T_n^+$, we obtain

$$Q_{\mathbf{m}}f(z) = \begin{cases} (1+z)^2 & \text{if } z \leq s_0^+ \\ r^{M,n}(z) - 2(m_1 + m_M M^2)z^2 & \text{if } s_n^+ \leq z \leq s_{n+1}^- \\ z^2 + 2(1-2\theta_n)z + 1 - \frac{4\theta_n(1-\theta_n)}{1+2m_1} & \text{if } s_n^- \leq z \leq s_n^+ \\ (1-z)^2 & \text{if } s_M^- \leq z, \end{cases}$$

where $r^{M,n}$ is the affine function

$$r^{M,n}(z) = P^{M,n}(s_n^+) + \frac{M(1+2(m_1 + m_M M^2))}{2} (P^{M,n+1}(s_{n+1}^-) - P^{M,n}(s_n^+))(z - s_n^+).$$

References

- [1] G. Alberti and G. Bellettini. . A non-local anisotropic model for phase transitions: asymptotic behaviour of rescaled energies. *European J. Appl. Math.* **9** (1998), 261–284.
- [2] G. Alberti, S. Müller. A new approach to variational problems with multiple scales. *Comm. Pure Appl. Math.* **54** (2001), 761–825.
- [3] R. Alicandro and M. Cicalese. A general integral representation result for continuum limits of discrete energies with superlinear growth. *SIAM J. Math. Anal.* **36** (2004), 1-37.

- [4] L. Ambrosio, N. Gigli, and G. Savaré. *Gradient Flows in Metric Spaces and in the Space of Probability Measures*. Birkhäuser, Basel 2005.
- [5] N. Ansini, A. Braides, and J. Zimmer. Minimising movements for oscillating energies: the critical regime. *Proc. Royal Soc. Edin. A*, **149** (2019), 719–737
- [6] S. Aubry. Exact models with a complete Devil’s staircase. *J. Phys. C Solid State Phys.* **16**(13) (1983), 2497–2508.
- [7] S. Aubry. The new concept of transitions by breaking of analyticity in a crystallographic model. In *Solitons and Condensed Matter Physics*. Springer, Berlin, 1978, 264–277.
- [8] S. Aubry. Defectibility and frustration in incommensurate structures: the devil’s staircase transformation. *Ferroelectrics* **24** (1980), 53–60.
- [9] S. Aubry and P.Y. Le Daeron. The discrete Frenkel-Kontorova model and its extensions: I. Exact results for the ground-states. *Phys. D: Nonlinear Phenom.* **8** (1983), 381–422.
- [10] P. Bak. Commensurate phases, incommensurate phases and the devil’s staircase. *Rep. Prog. Phys* **45** (1982), 587.
- [11] P. Bak and R. Bruinsma. One-dimensional Ising model and the complete devil’s staircase. *Phys. Rev. Lett.* **49** (1982), 249.
- [12] A.A.L. Baldelli, B. Bourdin, J.-J. Marigo, and C.Maurini. Fracture and debonding of a thin film on a stiff substrate: analytical and numerical solutions of a one-dimensional variational model. *Cont. Mech. Thermodyn.* **25** (2013), 243–268.
- [13] J.M. Ball and R.D. James. Fine phase mixtures as minimizers of energy. In *Analysis and Continuum Mechanics*. Springer, Berlin, 1989, 647–686.
- [14] V. Bangert. Mather sets for twist maps and geodesics on tori. In *Dynamics Reported*. Vieweg Teubner Verlag, Wiesbaden, 1988, 1–56
- [15] G. Bellettini, P. Buttà, and E. Presutti. Sharp interface limits for non-local anisotropic interactions. *Arch. Rational Mech. Anal.* **159** (2001), 109–135.
- [16] A. S. Besicovitch. *Almost Periodic Functions*. Dover, New York, 1954.
- [17] X. Blanc, C.Le Bris, and P.-L. Lions. From molecular models to continuum mechanics. *Arch. Rational Mech. Anal.* **164** (2002), 341–381.
- [18] A. Böttcher and S.M. Grudsky. *Toeplitz Matrices, Asymptotic Linear Algebra, and Functional Analysis*. Birkhäuser Verlag, Basel, 2000.
- [19] B. Bourdin, G. Francfort, and J.-J. Marigo. The variational approach to fracture. *J. Elast.* **91** (2008), 5–148.

- [20] A. Braides. *Approximation of Free-Discontinuity Problems*, Springer, Berlin, 1998.
- [21] A. Braides. *Γ -convergence for Beginners*. Oxford University Press, Oxford, 2002.
- [22] A. Braides. A handbook of Γ -convergence, in *Handbook of Differential Equations. Stationary Partial Differential Equations, Volume 3* (M. Chipot and P. Quittner, eds., Elsevier, 2006).
- [23] A. Braides. *Local Minimization, Variational Evolution and Γ -convergence*, Springer, Berlin, 2014.
- [24] A. Braides, A. Causin, and M. Solci. A homogenization result for interacting elastic and brittle media. *Proc. R. Soc. Lond. Ser. A Math. Phys. Eng. Sci.* **474** (2018).
- [25] A. Braides, and M. Cicalese. Surface energies in nonconvex discrete systems. *Math. Models Methods Appl. Sci.* **17** (2007), 985–1037.
- [26] A. Braides and A. Defranceschi. *Homogenization of Multiple Integrals*, Oxford University Press, Oxford, 1998.
- [27] A. Braides and M.S. Gelli. Continuum limits of discrete systems without convexity hypotheses. *Math. Mech. Solids* **7** (2002), 41–66.
- [28] A. Braides and M.S. Gelli. From discrete systems to continuous variational problems: an introduction. In *Topics on Concentration Phenomena and Problems with Multiple Scales* (A. Braides and V. Chiadò Piat, eds.), Springer, Berlin, 2006, 3–77.
- [29] A. Braides, M.S. Gelli, and M. Sigalotti. The passage from non-convex discrete systems to variational problems in Sobolev spaces: the one-dimensional case. *Proc. Steklov Inst. Math.* **236** (2002), 395–414
- [30] A. Braides, A.J. Lew, and M. Ortiz. Effective cohesive behavior of layers of interatomic planes. *Arch. Rational Mech. Anal.* **180** (2006), 151–182
- [31] A. Braides, M. Maslennikov, and L. Sigalotti. Homogenization by blow-up. *Appl. Anal.* **87** (2008) 1341–1356.
- [32] A. Braides and M. Solci. *Geometric Flow on Planar Lattices*. Birkhäuser, Basel 2021.
- [33] A. Braides and A. Tribuzio. Perturbed minimizing movements of families of functionals. *Discr. Cont. Dyn. Syst.-S* **14** (2021), 373–393
- [34] A. Braides and L. Truskinovsky. Asymptotic expansions by Gamma-convergence. *Cont. Mech. Therm.* **20** (2008), 21–62
- [35] O.M. Braun and Y.S. Kivshar. *The Frenkel-Kontorova Model: Concepts, Methods, and Applications*. Springer, Berlin, 2013.

- [36] H. Brezis, and H.-M. Nguyen. Γ -convergence of non-local, non-convex functionals in one dimension. *Commun. Contemp. Math.* **22** (2020), 1950077.
- [37] P. Cazeaux, and M. Luskin. Cauchy-Born strain energy density for coupled incommensurate elastic chains. *M2AN Math. Model. Numer. Anal.* **52** (2018), 729–749.
- [38] N. Chakrapani, B. Wei, A. Carrillo, P.M. Ajayan, and R.S. Kane. Capillarity-driven assembly of two-dimensional cellular carbon nanotube foams. *Proc. Nat. Acad. Sci. USA* **101** (2004), 4009–4012.
- [39] R. Choksi. Scaling laws in microphase separation of diblock copolymers. *J. Nonlinear Sci.* **11** (2001), 223–236.
- [40] S. Conti, G. Dolzmann, B. Kirchheim, and S. Müller. Sufficient conditions for the validity of the Cauchy-Born rule close to $SO(n)$. *J. Eur. Math. Soc.* **8** (2006), 515–539.
- [41] G. Dal Maso. *An Introduction to Γ -convergence*. Birkhäuser, Basel, 1994.
- [42] P.G. de Gennes. “Pincements” de Skoulios et structures incommensurables. *J. Phys. Lett.* **44** (1983), 657–664.
- [43] E. De Giorgi. Sulla convergenza di alcune successioni di integrali del tipo dell’area. *Rend. Mat.* **8** (1975), 277–294.
- [44] A. De Masi, E. Orlandi, E. Presutti, and L. Triolo: Glauber evolution with Kac potentials 1. Mesoscopic and macroscopic limits, interface dynamics. *Nonlinearity* **7** (1994), 663–696.
- [45] S. Dipierro, P. Miraglio, and E. Valdinoci. (Non)local Γ -convergence. *Bruno Pini Math. Anal. Seminar* **11** (2020), 68–93.
- [46] W. E, and P. Ming. Cauchy-Born rule and the stability of crystalline solids: static problems. *Arch. Rational Mech. Anal.* **183** (2007), 241–297.
- [47] J. Ericksen. On the Cauchy-Born rule. *Math. Mech. Solids* **13** (2008), 199–220.
- [48] L.C. Evans and R.F. Gariepy. *Measure Theory and Fine Properties of Functions*. CRC Press, Boca Raton, 2015.
- [49] A. Fathi. *The Weak KAM Theorem in Lagrangian Dynamics*. Cambridge University Press, Cambridge, 2010.
- [50] M.E. Fisher and W. Selke. Infinitely many commensurate phases in a simple Ising model. *Phys. Rev. Lett.* **44** (1980), 1502.
- [51] I. Fonseca and G. Leoni. *Modern Methods in the Calculus of Variations: L^p spaces*. Springer, New York, 2007.

- [52] I. Fonseca and S. Müller. Quasiconvex integrands and lower semicontinuity in L^1 . *SIAM J. Math. Anal.* **23** (1992), 1081–1098.
- [53] G.A. Francfort and J.J. Marigo. Revisiting brittle fracture as an energy minimization problem. *J. Mech. Phys. Solids* **46** (1998), 1319–1342.
- [54] E. Garibaldi and P. Thieullen. Minimizing orbits in the discrete Aubry-Mather model. *Nonlinearity* **24**(2) (2011), 563–611.
- [55] A. Geim, S.V. Dubonos, I.V. Grigorieva, K.S. Novoselov, A.A. Zhukov and S.Y. Shapoval. Microfabricated adhesive mimicking gecko foot-hair. *Nat. Mater.* **2** (2003), 461–463.
- [56] A. Giuliani, J. L. Lebowitz, and E.H. Lieb. Ising models with long-range antiferromagnetic and short-range ferromagnetic interactions. *Phys. Rev. B* **74** (2006), 064420
- [57] C. Godrèche and L. de Seze. Pincements de Skoulios-de Gennes: observations numériques. *J. Phys. Lett.* **46** (1985), 39–48.
- [58] D. Goldman, C. B. Muratov, and S. Serfaty. The Γ -limit of the two-dimensional Ohta-Kawasaki energy. I. Droplet density. *Arch. Rational Mech. Anal.* **210** (2013), 581–613,
- [59] D. A. Gomes. Viscosity solution method and the discrete Aubry-Mather problem *Discrete Contin. Dyn. Syst.* **13** (2005) 103–116
- [60] Y. Grabovsky and L. Truskinovsky. The flip side of buckling. *Cont. Mech. Therm.* **19**(3) (2007), 211–243.
- [61] Y. Grabovsky and L. Truskinovsky. Normality condition in Elasticity. *J. Nonlinear Sci.* **24** (2014), 1125–1146.
- [62] R.B. Griffiths. Frenkel-Kontorova models of commensurate-incommensurate phase transitions. *Fundamental Problems in Statistical Mechanics* **7** (1990), 69–110.
- [63] R.B. Griffiths and W. Chou. Effective potentials: a new approach and new results for one-dimensional systems with competing length scales. *Phys. Rev. Lett.* **56** (1986), 1929.
- [64] K. Hood and A. Caillé. Ground states of coupled double-chain models. *Phys. Rev. A* **42** (1990), 2150.
- [65] T. Hudson and C. Ortner. On the stability of Bravais lattices and their Cauchy-Born approximations. *M2AN Math. Model. Numer. Anal.* **46** (2012), 81–110.
- [66] J. Hutchinson and Z. Suo. Mixed mode cracking in layered materials. *Adv. Appl. Mech.* **29** (1991), 63–191.
- [67] T. Janssen and A. Janner. Incommensurability in crystals. *Adv. Phys.* **36** (1987), 519–624.

- [68] R.V. Kohn. The relaxation of a double-well energy. *Cont. Mech. Therm.* **3** (1991), 193–236.
- [69] A.R. Khoei, M.A. Qomi, M.T. Kazemi, and A. Aghaei. An investigation on the validity of Cauchy-Born hypothesis using Sutton-Chen many-body potential. *Comput. Mater. Sci.* **44** (2009), 999–1006.
- [70] S. M. Kozlov. Averaging of random operators. *Mat. Sb. (N.S.)* **109** (1979), 188–202
- [71] J. Kristensen. On the non-locality of quasiconvexity. *Ann. Inst. H. Poincaré Anal. Non Linéaire* **16** (1999), 1–13.
- [72] E.-C. Lee and C. Kee-Joo. Ferromagnetic versus antiferromagnetic interaction in Co-doped ZnO. *Physical Review B* **69** (2004), 085205.
- [73] A.A. León Baldelli, B. Bourdin, J.J. Marigo, and C. Maurini. Fracture and debonding of a thin film on a stiff substrate: analytical and numerical solutions of a one-dimensional variational model. *Cont. Mech. Therm.* **25** (2012), 243–268.
- [74] B.M. Levitan and V.V. Zhikov. *Almost Periodic Functions and Differential Equations*. Cambridge University Press, Cambridge, 1982.
- [75] M. Lewin, X. Blanc, The crystallization conjecture: a review. *EMS Surv. Math. Sci.* **2** (2015), 255–306
- [76] C. Makridakis and E. Süli. Finite element analysis of Cauchy-Born approximations to atomistic models. *Arch. Rational Mech. Anal.* **207** (2013), 813–843.
- [77] M. Marchand, K. Hood, and A. Caillé. Non-convex interactions and the occurrence of modulated phases. *Phys. Rev. Lett.* **58** (1987), 1660.
- [78] M. Marchand, K. Hood, and A. Caillé. Non-convex interactions: a mechanism for the occurrence of modulated order in condensed matter. *Phys. Rev. B* **37** (1988), 1898.
- [79] J. Mather. Existence of quasi-periodic orbits for twist homeomorphisms of the annulus. *Topology* **21** 457–467
- [80] P. Meakin. A simple model for elastic fracture in thin films. *Thin Solid Films* **151** (1987), 165–190.
- [81] G. Meurant. A review on the inverse of symmetric tridiagonal and block tridiagonal matrices. *SIAM J. Matrix Anal. Appl.* **13** (1992), 707–728.
- [82] S. Müller. Homogenization of nonconvex integral functionals and cellular elastic materials. *Arch. Rational Mech. Anal.* **99** (1987), 189–212.

- [83] S. Müller. Singular perturbations as a selection criterion for periodic minimizing sequences. *Calc. Var. Partial Differential Equations* **1** (1993), 169–204.
- [84] I. Novak and L. Truskinovsky. Nonaffine response of skeletal muscles on the ‘descending limb’. *Math. Mech. Solids* **20**(6) (2015), 697–720.
- [85] I. Novak and L. Truskinovsky. Segmentation in cohesive systems constrained by elastic environments. *Philos. Trans. Roy. Soc. A* **375** (2017), 20160160, 16 pp.
- [86] S. Pagano, and R. Paroni. A simple model for phase transitions: from the discrete to the continuum problem. *Quart. Appl. Math.* **61** (2003), 89–109.
- [87] B. Pokroy, S.H. Kang, L. Mahadevan, and J. Aizenberg. Self-organization of a mesoscale bristle into ordered, hierarchical helical assemblies. *Science* **323** (2009), 237–240.
- [88] C. Pozrikidis. On the applicability of the Cauchy-Born rule. *Comput. Mater. Sci.* **46** (2009), 438–442.
- [89] G. Puglisi and L. Truskinovsky. Thermodynamics of rate-independent plasticity. *Journal of the Mechanics and Physics of Solids* **53** (2005), 655–679.
- [90] X. Ren, and L. Truskinovsky. Finite scale microstructures in nonlocal elasticity. *J. Elasticity* **59** (2000), 319–355.
- [91] Z. Rieder, J. L. Lebowitz, and W. E. Properties of a harmonic crystal in a stationary nonequilibrium state. *J. Math. Phys.* **8** (1967), 1073–1078.
- [92] R.C. Rogers and L. Truskinovsky. Discretization and hysteresis. *Physica B: Condensed Matter* **233** (1997), 370–375.
- [93] D. Ruelle. Smooth dynamics and new theoretical ideas in nonequilibrium statistical mechanics. *J. Stat. Phys.* **95** (1999), 393–468.
- [94] W. Selke. The ANNNI model: theoretical analysis and experimental application. *Physics Reports* **170**(4) (1988), 213–264.
- [95] P. Steinmann, A. Elizondo, and R. Sunyk. Studies of validity of the Cauchy-Born rule by direct comparison of continuum and atomistic modelling. *Model. Simul. Mat. Sci. Eng.* **1** (2006), S271.
- [96] L. Truskinovsky. Fracture as a phase transition. In *Contemporary Research in the Mechanics and Mathematics of Materials*, CIMNE, Barcelona, 1996, 322–332.
- [97] L. Truskinovsky, G. Vitale, and T.H. Smit. A mechanical perspective on vertebral segmentation. *Int. J. Eng. Sci.* **83** (2014), 124–137.

- [98] W.P. Vellinga, M. Van den Bosch, and M.G.D. Geers. Interaction between cracking, delamination and buckling in brittle elastic thin films. *Int. J. Fract.* **154** (2008), 195–209.
- [99] K. Wang, M. Cai, P. Zhou, and G. Hu. Homogenization in a simpler way: analysis and optimization of periodic unit cells with Cauchy-Born hypothesis. *Struct. Multidisc. Optim.* **64** (2021), 3911–3935
- [100] G. Zanzotto. The Cauchy-Born hypothesis, nonlinear elasticity and mechanical twinning in crystals. *Acta Crystallogr. A* **52** (1996), 839–849.