

SYMMETRY AND RIGIDITY OF MINIMAL SURFACES WITH PLATEAU-LIKE SINGULARITIES

JACOB BERNSTEIN AND FRANCESCO MAGGI

ABSTRACT. By employing the method of moving planes in a novel way we extend some classical symmetry and rigidity results for smooth minimal surfaces to surfaces that have singularities of the sort typically observed in soap films.

1. INTRODUCTION

1.1. Overview. Minimal surfaces in \mathbb{R}^3 provide the standard mathematical model of soap films at equilibrium. Nevertheless, there is a historical mismatch between the classical theory of minimal surfaces, which focuses on smooth immersions with vanishing mean curvature, and the richer structures documented experimentally since the pioneering work of Plateau [Pla73]. Indeed, two types of singular points are observed in soap films, called Y and T points; see Figure 2 below. We call the surfaces described in experiments *minimal Plateau surfaces* and ask:

To what extent may the classical theory of minimal surfaces be generalized to minimal Plateau surfaces and what new conclusions may be drawn?

This paper studies this question in the model case provided by **Schoen's rigidity theorem for catenoids** [Sch83]: a (classical) minimal surface in \mathbb{R}^3 spanning two parallel circles with centers on the same axis has rotational symmetry about this axis and so is either a pair of flat disks or a subset of a catenoid. Schoen's theorem is an interesting model case for two reasons: (i) its extension to minimal Plateau surfaces requires the inclusion of new cases of rigidity, given by singular catenoids; (ii) Schoen's proof uses Alexandrov's method of moving planes [Ale62], which has been almost exclusively applied in the smooth setting; thus its adaptation to a class containing singular surfaces is notable. The only other application of the moving planes method in a non-smooth setting that we are aware of is the recent work [CHHW19, HHW20]. However, in that work *a posteriori* regularity is derived from the moving planes method despite allowing *a priori* singularities. This is unlike our applications in which genuinely singular surfaces are symmetric examples; see Figure 1.

This introduction is organized as follows. In Section 1.2 we recall the rigidity theorems from [Sch83]. In Sections 1.3 and 1.4 we define Plateau surfaces and introduce a notion of orientability for them, that we call the cell structure condition. In Section 1.5 we state our main results, which extend Schoen's rigidity theorems to minimal Plateau surfaces. Finally, in Sections 1.6 and 1.7 we discuss further the physical and mathematical motivations for Plateau surfaces and situate them within the more general frameworks provided by geometric measure theory.

JB was partially supported by the NSF Grant DMS-1609340 and DMS-1904674. FM was partially supported by the NSF Grants DMS-156535 and DMS-FRG-1854344.

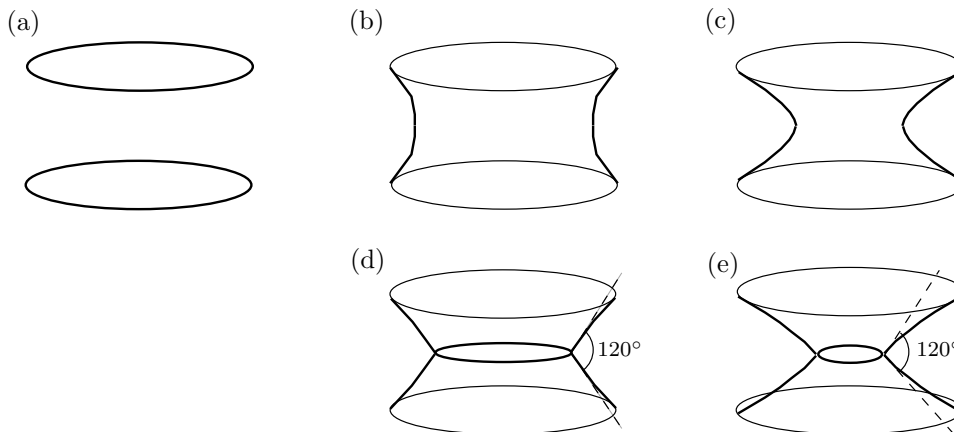

FIGURE 1. Two parallel circles with same radii lying at a sufficiently small distance span exactly three smooth minimal surfaces: a pair of disks, a “fat” catenoid (which is stable) and a “skinny” catenoid (which is unstable). The same circles span five minimal Plateau surfaces, the two new cases being defined by a pair of “singular” Y -catenoids.

1.2. Schoen’s rigidity theorems. The *first rigidity theorem* proved in [Sch83] states that a minimal immersion of a compact connected surface with boundary consisting of a pair of coaxial circles in parallel planes is, up to rigid motion and dilation, a piece of the catenoid. Here the catenoid is the minimal surface

$$\text{Cat} = \{x_1^2 + x_2^2 = \cosh^2 x_3\} .$$

The *second rigidity theorem* is more global in nature. It says that, up to rigid motion and dilation, any complete minimal immersion that is regular at infinity and has two ends, must either be a catenoid or a pair of planes. Here, a surface is *regular at infinity* if after removing a sufficiently large compact set, each remaining component of the surface is modeled on either a catenoidal or planar end. In both rigidity theorems the hypotheses that the minimal surface be an immersion is essential, as can be seen by the example of the Y -catenoid,

$$\text{Cat}_Y = \{x_1^2 + x_2^2 = \cosh^2(|x_3| + h_0)\} \cup \{3(x_1^2 + x_2^2) \leq 4, x_3 = 0\}$$

(where $h_0 = \log(3)/2$ is the unique solution to $\sinh h_0 = 1/\sqrt{3}$). Indeed, Cat_Y is minimal both in a distributional sense (that is, as a stationary 2-dimensional varifold in \mathbb{R}^3) and is the prototypical example of what we call a minimal Plateau surface.

1.3. Plateau surfaces. Let \mathcal{K} a family of cones in \mathbb{R}^3 with vertex the origin with

$$\{P, H\} \subset \mathcal{K} ,$$

where $P = \{x_3 = 0\}$ is a plane and $H = \{x_3 = 0, x_1 \geq 0\}$ a half-plane, and so that all the elements of \mathcal{K} are distinct up to rotations. In particular, if $K \in \mathcal{K} \setminus \{P, H\}$, then K is neither a plane nor a half-plane. Given $U \subset \mathbb{R}^3$ open, a closed subset $\Sigma \subset U$ is a \mathcal{K} -**surface in U** if, for some $\alpha \in (0, 1)$ and for all $p \in \Sigma \cap U$, there is an $r > 0$ and a $C^{1,\alpha}$ -regular diffeomorphism $\phi : B_r(p) \subset U \rightarrow \mathbb{R}^3$ so that $\phi(\Sigma \cap B_r(p)) \in \mathcal{K}$ and $D\phi_p \in O(3)$, i.e., $D\phi_p$ is an orthogonal linear transformation. The element of \mathcal{K} corresponding to $p \in \Sigma$ is unique and is denoted by

$$\hat{T}_p \Sigma \in \mathcal{K} .$$

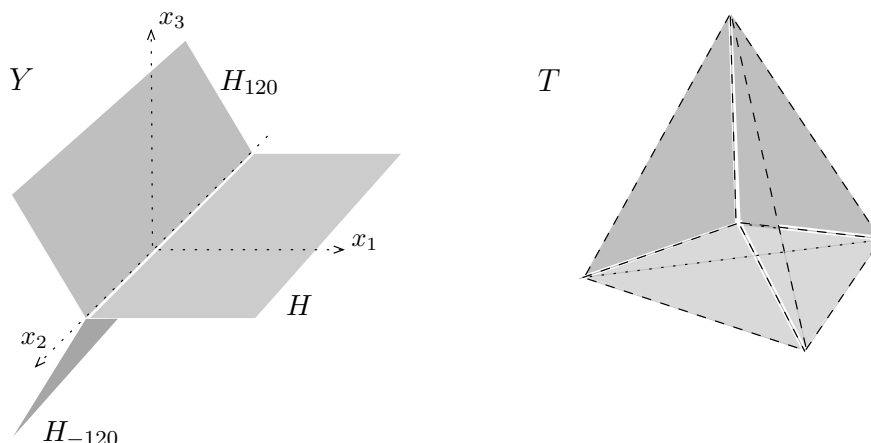

FIGURE 2. The model Y and T cones in \mathcal{K} . Here $H = \{x_3 = 0, x_1 \geq 0\}$ and H_θ is obtained by rotating H around the x_2 -axis by θ -degrees.

The **tangent cone** of Σ at p , denoted $T_p\Sigma$, is defined by $D\phi_p(T_p\Sigma) = \hat{T}_p\Sigma$. Clearly, $T_p\Sigma = \lim_{\rho \rightarrow 0^+} (\Sigma - p)/\rho$ where the limit is in the pointed Hausdorff sense.

For each $K \in \mathcal{K}$, we let $\Sigma_K = \{p \in \Sigma \cap U : \hat{T}_p\Sigma = K\}$. Correspondingly, we identify the sets of **interior points** $\text{int}(\Sigma) = \Sigma_P$, of **boundary points** $\partial\Sigma = \Sigma_H$, of **regular points** $\text{reg}(\Sigma) = \text{int}(\Sigma) \cup \partial\Sigma$, and of singular points $\text{sing}(\Sigma) = \Sigma \setminus \text{reg}(\Sigma)$. By construction, an Hölder continuous vector field ν_Σ^{nt} of **outer unit conormals** to Σ can be defined along $\partial\Sigma$. When $\text{sing}(\Sigma) = \emptyset$, the notion of \mathcal{K} -surface reduces to that of **regular surface** (with boundary and of class $C^{1,\alpha}$) in U .

A (relatively) closed subset $\Sigma \subset U$, in an open subset $U \subset \mathbb{R}^3$, is a **Plateau surface in U** if: **(a)** Σ is a \mathcal{K} -surface in U for

$$(1.1) \quad \mathcal{K} = \{P, H, Y, T\},$$

where $Y = H \cup H_{120} \cup H_{-120}$ (and H_θ is the rotation of H by θ -degrees about the x_2 -axis), and T is the cone over the edges of a reference regular tetrahedron centered at the origin, see Figure 2; **(b)** each connected component of $\text{int}(\Sigma)$ has (weak) constant mean curvature. If $\text{int}(\Sigma)$ has zero mean curvature, then Σ is a **minimal Plateau surface in U** . When $\Sigma_T = \emptyset$, one calls Σ a **Y -surface**.

Remark 1.1. If Σ is a Plateau surface, then $\Sigma \setminus (\partial\Sigma \cup \Sigma_T)$ admits smooth (in fact real-analytic) charts. Indeed, standard elliptic regularity ensures the smoothness of any $C^{1,\alpha}$ -graph whose mean curvature is constant in a weak sense and so $\text{int}(\Sigma)$ consists of smooth surfaces. Furthermore, work of Kinderlehrer, Nirenberg and Spruck [KNS78, Theorem 5.2] implies that each component of Σ_Y is a smooth curve.

1.4. Orientability of Plateau surfaces. We introduce a notion of orientability in the Plateau setting that generalizes the notion of a regular surface separating an ambient three-manifold. A Plateau surface Σ **defines a cell structure** in $U \subset \mathbb{R}^3$ open, if there exists a family of open, connected sets $\mathcal{C}(\Sigma) = \{U^i : 1 \leq i \leq N\}$, called the **cells of Σ** , such that

$$(1.2) \quad \partial\Sigma \subset \partial U, \quad U \setminus \Sigma = \bigcup_{i=1}^N U^i$$

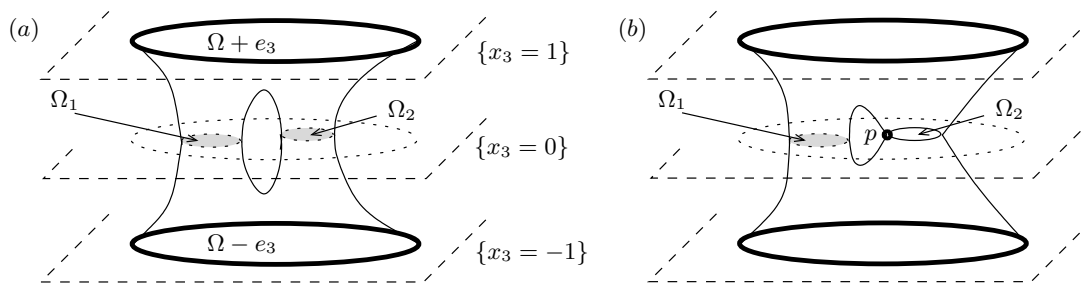

FIGURE 3. Illustrations of the definition of minimal Plateau bi-graph: (a) a regular minimal Plateau bi-graph that is not simple; (b) a non-simple minimal Plateau bi-graph Σ with non-trivial singular set; notice that in this case Ω_1 is not part of Σ , but $\Omega_2 \subset \Sigma$, with $\partial\Omega_2 = \text{sing}(\Sigma) = \Sigma_Y$.

and, for each $p \in \Sigma$ there is a $\rho > 0$ so $B_\rho(p) \subset U$ and, for each $0 < \rho' < \rho$ and $i = 1, \dots, N$, $B_{\rho'}(p) \cap U^i$ is connected (possibly empty).

Clearly, Cat defines a cell structure in \mathbb{R}^3 with two cells while Cat_Y defines a cell structure in \mathbb{R}^3 with three cells. An example of a surface not defining a cell structure is illustrated in Figure 3-(b). A connected regular surface defines a cell structure in U when it is separating in U . Observe that the tetrahedral cone $T \subset \mathbb{R}^3$ defines a cell structure in \mathbb{R}^3 but is not a flat chain mod 3.

1.5. Schoen's rigidity theorems for Plateau surfaces. Let us recall some notation and terminology from [Sch83]. A set $\Sigma \subset \mathbb{R}^3$ is a **graph** if $\pi|_\Sigma : \Sigma \rightarrow \mathbb{R}^2$ is one-to-one, where $\pi : \mathbb{R}^3 \rightarrow \mathbb{R}^2$ is the projection $\pi((\mathbf{y}, x_3)) = \mathbf{y}$. We say that Σ is a **graph of locally bounded slope** if it is a graph and there exists a (one- or two-dimensional) C^1 -submanifold σ of \mathbb{R}^3 such that $\Sigma = \bar{\sigma}$ and such that $T_p\sigma$ is transverse to \mathbf{e}_3 for each $p \in \sigma$ – for example, $\Sigma = \{x_3 \geq 0, x_1^2 + x_2^2 + x_3^2 = 1\}$ and $\Sigma = \{x_3 \geq 0, x_2 = 0, x_1^2 + x_3^2 = 1\}$ are both graphs of locally bounded slope.

Given an open subset $\Omega \subset \mathbb{R}^2$, let

$$C_\Omega = \{(\mathbf{y}, z) : \mathbf{y} \in \Omega\} \subset \mathbb{R}^3$$

be the cylinder over Ω . A **minimal Plateau bi-graph** over Ω is a (not necessarily connected) minimal Plateau surface, Σ , satisfying $\Sigma \subset \bar{C}_\Omega$, $\partial\Sigma = \Sigma \cap \partial C_\Omega$, and so

$$\Sigma_{0+} = \Sigma \cap \{x_3 \geq 0\} \quad \text{and} \quad \Sigma_{0-} = \Sigma \cap \{x_3 \leq 0\},$$

are both graphs of locally bounded slope; see Figure 3. Clearly, such Σ must have $\Sigma_T = \emptyset$, $\Sigma_Y \subset \{x_3 = 0\}$, and if $p \in \Sigma_Y$, then the spine of $T_p\Sigma$ is contained in $\{x_3 = 0\}$. If, in addition, $\Sigma \cap \{x_3 = 0\}$ is empty or is the boundary of a single topological disk contained in $\{x_3 = 0\}$, then Σ is **simple**. For instance, $\text{Cat} \cap \bar{C}_{BR}$, $\{|x_3| = 1\} \cap \bar{C}_R$ and $\text{Cat}_Y \cap \bar{C}_{BR}$ are all simple minimal Plateau bi-graphs for appropriate R . Simple minimal Plateau bi-graphs define a cell structure in C_Ω , but this is not necessarily the case when Σ is not simple; see Figure 3-(b).

Our extension of Schoen's first rigidity result to the Plateau setting is as follows.

Theorem 1.2. *Let $\Omega \subset \mathbb{R}^2$ be a bounded, open convex set with C^1 -boundary, and let Σ be a compact, minimal Plateau surface in \mathbb{R}^3 with*

$$\partial\Sigma = (\partial\Omega) \times \{1, -1\}.$$

If Σ defines a cell structure in $U = \{|x_3| < 1\}$, then Σ is a simple minimal Plateau bi-graph, which is symmetric by reflection through $\{x_3 = 0\}$. Moreover, if Ω is the

interior of a circle, then Σ is either a union of two disks, or, up to translation and dilation, is a subset of Cat or of Cat_Y .

Remark 1.3. Unlike Schoen’s first result, our proof does not apply to arbitrary pairs of coaxial circles. However, we expect the more general result is also true.

We also obtain an analog of Schoen’s second rigidity theorem. Namely, global rigidity and symmetry for minimal Plateau surfaces with two regular ends that are subject to the same orientability condition used in the previous theorem.

Theorem 1.4. *Let Σ be a minimal Plateau surface that defines a cell structure in \mathbb{R}^3 . If there is an $R_0 > 0$ so that $\Sigma \setminus B_{R_0}$ has two regular ends, then, up to a rigid motion and dilation, Σ is either a pair of planes, a catenoid or a Y -catenoid.*

Remark 1.5. It is unclear whether the assumption that the minimal Plateau surfaces define cell structures in Theorems 1.2 and 1.4 are necessary or just a technical hypothesis needed for our proof. This point is further discussed in Section 5.

1.6. Physical and mathematical motivation. The physical motivation for the notion of Plateau surface proposed in this paper lies in the celebrated Plateau’s laws, which are empirical observations about the geometric structure of soap films. Plateau’s laws state that soap films at equilibrium are arranged into smooth surfaces with constant mean curvature, meeting in threes along edges at 120° degrees angles; and that these edges meet in four at vertex points, and they do so at the angles defined by the skeleton of a regular tetrahedron. The definition given in Section 1.3 simply captures, in exact mathematical terms, all the features listed in Plateau’s laws – as explained in Remark 1.1, the $C^{1,\alpha}$ -regularity requirement is purely technical. This corresponds physically to films arising in clusters of soap bubbles while minimal Plateau surfaces correspond to films spanning a fixed “wire frame”.

The mathematical justification for our definition of Plateau surface is given by Taylor’s theorem [Tay76]. Indeed, Taylor proved that if $U \subset \mathbb{R}^3$ is open, Σ is a relatively compact and rectifiable set in U , $\Sigma = U \cap \text{spt}(\mathcal{H}^2 \llcorner \Sigma)$, and, for some $\alpha > 2$,

$$(1.3) \quad \mathcal{H}^2(\Sigma) \leq \mathcal{H}^2(\varphi(\Sigma)) + C r^\alpha$$

whenever $\{\varphi \neq \text{id}\} \subset B_r(x) \subset\subset U$, $x \in \Sigma$ and $\text{Lip } \varphi < \infty$, then, in our terminology, Σ is a \mathcal{K} -surface without boundary in U where \mathcal{K} is as in (1.1). Moreover, when $C = 0$, Σ is a minimal Plateau surface.

The significance of Taylor’s theorem is that it explains the (interior) singularities observed by Plateau solely in terms of the geometric calculus of variations. Various “non-distributional approaches to Plateau’s problem” have been proposed to show the existence of compact sets Σ satisfying (1.3) with $C = 0$ and with U given by the complement of a compact “wire frame”: these include, at least, Reifenberg’s approach of homological spanning conditions, the Harrison-Pugh approach of homotopic spanning conditions, and David’s notion of sliding minimizers; see [Rei60, Rei64a, Rei64b, Dav14, Fan16, FK18, HP16, HP17, DLGM17, DLDRG19] and other related papers. These approaches provide rigorous constructions of many minimal Plateau surfaces – though care has to be taken at the boundary; see below.

1.7. Rigidity theorems in more general non-smooth settings. Plateau surfaces provide an interesting “semi-classical” setting to which extending the theory of minimal surfaces. The same goal could however be pursued in even more general settings – specifically those provided by geometric measure theory (GMT). There are two major motivations for this.

First of all, the two-dimensional area minimizing surfaces in \mathbb{R}^3 constructed by the non-distributional approaches to Plateau’s problem mentioned above (e.g., [Rei60, HP16, DLGM17, Dav14]), as well as those found in distributional approaches (e.g., flat chains modulo 3 [Tay73]), may possess boundary singularities. This is not a purely theoretical issue as boundary singularities are also observed in physical soap films. Thus, it is natural to consider a more general notion of Plateau surface where boundary behavior is not modeled only by the half-plane H , but by more general cones. In particular, Plateau surfaces as introduced here should be properly understood as “Plateau surfaces with regular boundary”. A list of possible boundary singularities is described in [LM96, Section 5.2 and Figure 5.3], although not all the examples in that list are likely to be locally area minimizing (i.e., physical), and so it is unclear what the correct modification of the definition adopted in this paper should be. By working in the language of GMT one sidesteps this difficulty by working in a class large enough to encompass all possible boundary singularities.

Secondly, GMT provides powerful compactness theorems which, in turn, allow one to turn rigidity theorems like Theorem 1.2 into interesting perturbative results. For instance, in the case of the volume-preserving mean curvature flow, a characterization of equilibrium states requires the generalization of the classical Alexandrov’s theorem (smooth boundaries with constant mean curvature enclosing finite volumes are spheres [Ale62]) to the class of sets of finite perimeter and finite volume with constant distributional mean curvature; see [DM19]. In a similar vein, Theorem 1.2 could be used to understand the long time behavior of (singular) mean curvature flows with fixed boundary given by two parallel convex curves; see [ST19].

With these motivations in mind, in the follow-up paper [BM20] we extend the reach of our rigidity theorems from minimal Plateau surfaces to an appropriate class of stationary varifolds.

1.8. Organization of the paper. In Section 2 we present the key technical statement of the paper, Theorem 2.5. Sections 3 and 4 contain, respectively, the proofs of Theorem 1.2 and Theorem 1.4, while in Section 5 we collect some open questions.

2. MOVING PLANES FOR MINIMAL PLATEAU SURFACES IN A CYLINDER

In Section 2.1 we prove a removable singularity result and a unique continuation principle for minimal Plateau surfaces and record a simple observation about the infinitesimal structure of cellular surfaces. In Section 2.2 we provide conditions so an infinitesimal reflection symmetry in a minimal Plateau surface propagates to a global symmetry. Finally, in Section 2.3 we present the main moving planes argument.

For future extensions to varifolds – see [BM20] – the results of this section will be proved for a more general class of surfaces than minimal Plateau surfaces. Specifically, we consider a closed set, Σ , that is a minimal Plateau surface away from a discrete set, Q , of potentially exotic singularities. We show that, under certain natural conditions on these singularities, neither they nor T -points occur in the region

in which the moving planes method applies – i.e., Σ is a Y -surface in this region. More precisely, we require that, at the points of Q , Σ has upper density strictly less than 2. Here the **upper density of Σ at p** is defined to be

$$\bar{\Theta}(\Sigma, p) = \limsup_{r \rightarrow 0^+} \frac{\mathcal{H}^2(\Sigma \cap B_r(p))}{\pi r^2},$$

When the usual limit exists, we denote it by $\Theta(\Sigma, p)$ and call it the **density of Σ at p** . If Σ is a minimal Plateau surface in a neighborhood of p , then $\bar{\Theta}(\Sigma, p) < 2$ as,

$$(2.1) \quad \Theta(\Sigma, p) = \begin{cases} 1/2, & \text{if } p \in \partial\Sigma, \\ 1, & \text{if } p \in \text{int}(\Sigma), \\ 3/2, & \text{if } p \in \Sigma_Y, \\ \frac{6}{2\pi} \arccos(-1/3) \approx 1.82, & \text{if } p \in \Sigma_T. \end{cases}$$

2.1. Removable singularities and unique continuation. We first prove a simple removable singularities result for minimal Plateau surfaces. It will be helpful to observe that if Σ is a minimal Plateau surface in U , then, for any $X \in C_c^1(U; \mathbb{R}^3)$,

$$(2.2) \quad \int_{\text{reg}(\Sigma)} \text{div}^\Sigma X \, d\mathcal{H}^2 = \int_{\partial\Sigma} X \cdot \nu_\Sigma^{co} \, d\mathcal{H}^1,$$

In particular, the rectifiable varifold, V_Σ , defined by Σ is stationary in $U \setminus \partial\Sigma$.

Lemma 2.1 (Removable singularities for minimal Plateau surfaces). *Let Σ be a closed subset of $B_R = B_R(0)$ without isolated points so that $\Sigma \setminus \{0\}$ is a minimal Plateau surface without boundary in $B_R \setminus \{0\}$. If $\bar{\Theta}(\Sigma, 0) < 2$ and $\Sigma \cap \{x_3 \geq 0\}$ is a graph of locally bounded slope, then Σ is a minimal Plateau surface in B_R . When $0 \in \Sigma$, $0 \in \text{int}(\Sigma) \cup \Sigma_Y$ and if 0 is a Y -point, then the spine of $T_0\Sigma$ lies on $\{x_3 = 0\}$.*

Proof. Since Σ is closed in B_R , if $0 \notin \Sigma$, then $B_r \cap \Sigma = \emptyset$ for some $r > 0$, and thus the fact that Σ is a minimal Plateau surface in $B_R \setminus \{0\}$ implies that Σ is a minimal Plateau surface in B_R . We can thus assume that $0 \in \Sigma$.

Step one: We first prove that

$$(2.3) \quad \int_{\text{reg}(\Sigma)} \text{div}^\Sigma X = 0 \quad \forall X \in C_c^\infty(B_R; \mathbb{R}^3),$$

that is, the rectifiable varifold V_Σ defined by Σ is stationary in B_R . As (2.2) holds for Σ in $B_R \setminus \{0\}$, we have $\int_{\text{reg}(\Sigma)} \text{div}^\Sigma Y \, d\mathcal{H}^2 = 0$ for every $Y \in C_c^\infty(B_R \setminus \{0\}; \mathbb{R}^3)$. Setting $Y = \eta_\varepsilon X$ for $X \in C_c^\infty(B_R; \mathbb{R}^3)$ and η_ε a smooth cutoff with $\eta_\varepsilon = 1$ on $\mathbb{R}^3 \setminus B_\varepsilon$ and $\eta_\varepsilon = 0$ on $B_{\varepsilon/2}$, we thus find

$$\int_{\text{reg}(\Sigma)} \eta_\varepsilon \text{div}^\Sigma X = - \int_{\text{reg}(\Sigma)} X \cdot \nabla \eta_\varepsilon.$$

Choosing η_ε so that $\eta_\varepsilon \rightarrow 1$ on $\mathbb{R}^3 \setminus \{0\}$ and $|\nabla \eta_\varepsilon| \leq 1_{B_\varepsilon \setminus B_{\varepsilon/2}} C/\varepsilon$, we have

$$\left| \int_{\text{reg}(\Sigma)} \text{div}^\Sigma X \right| \leq C \|X\|_{C^0} \limsup_{\varepsilon \rightarrow 0^+} \frac{\mathcal{H}^2(\Sigma \cap B_\varepsilon)}{\varepsilon} = 0,$$

where we have used $\bar{\Theta}(\Sigma, 0) < \infty$ to deduce $\mathcal{H}^2(\Sigma \cap B_\varepsilon) = o(\varepsilon)$ as $\varepsilon \rightarrow 0^+$. We have thus proved that (2.3) holds.

Step two: We show that $\Theta(\Sigma, 0)$ exists and belongs to $[1, 2)$. By (2.3), $\Theta(\Sigma, p)$ exists at every $p \in B_R$ and defines an upper-semicontinuous function on B_R . As Σ contains no isolated points and $0 \in \Sigma$, there are $p_j \rightarrow 0$ as $j \rightarrow \infty$ with $p_j \in \Sigma \setminus \{0\}$. By upper semicontinuity of $\Theta(\Sigma, \cdot)$ in B_R we have

$$\Theta(\Sigma, 0) \geq \limsup_{j \rightarrow \infty} \Theta(\Sigma, p_j) \geq 1,$$

where we have used (2.1) and the assumption that Σ has no boundary points in $B_R \setminus \{0\}$ to obtain $\Theta(\Sigma, p_j) \geq 1$ for every j . Hence, $1 \leq \Theta(\Sigma, 0) \leq \bar{\Theta}(\Sigma, 0) < 2$.

Step three: As $\Sigma \cap \{x_3 \geq 0\}$ is a graph of locally bounded slope and Σ is a minimal Plateau surface without boundary in $B_R \setminus \{0\}$, it follows that $\Sigma \cap \{x_3 > 0\}$ is a smooth, stable minimal surface in $B_R \cap \{x_3 > 0\}$. It is possible this set is empty. Hence, for $q \in \Sigma \cap \{x_3 > 0\} \cap B_{R/2}$, Σ is a stable minimal surface in $B_{x_3(q)}(q)$, and thus, by the curvature estimates of Fischer-Colbrie and Schoen [FCS80],

$$(2.4) \quad |A_\Sigma(q)| \leq \frac{C}{x_3(q)}, \quad \forall q \in \Sigma \cap B_{R/2} \cap \{x_3 > 0\}$$

where here $C > 0$ is a universal constant. Given a sequence of radii $\rho_i \rightarrow 0^+$, up to extracting a subsequence, the multiplicity one varifolds V_{Σ/ρ_i} have a varifold limit \mathcal{C} which is stationary in \mathbb{R}^3 , supported on a cone $K = \text{spt}\mathcal{C}$ with vertex at 0, and with upper semicontinuous and integer valued density θ . Since (2.4) implies

$$|A_{\Sigma/\rho_i}(q)| \leq \frac{C}{x_3(q)}, \quad \forall q \in \Sigma/\rho_i \cap B_{R/2\rho_i} \cap \{x_3 > 0\}$$

we deduce that $K \cap \{x_3 > 0\}$ is a smooth minimal surface. By the upper semicontinuity of density, by $\Theta(\mathcal{C}, 0) \in [1, 2)$ and since \mathcal{C} is integer multiplicity, we deduce that $\Theta(\mathcal{C}, q) = 1$ for every $q \in K \cap \{x_3 > 0\}$. As \mathcal{C} is a cone, this means that

$$\mathcal{C} \llcorner \{x_3 \geq 0\} = \sum_{i=1}^N V_{H_i}$$

where $H_i \subset \{x_3 \geq 0\}$ are half-planes with $\partial H_i = \ell \subset \{x_3 = 0\}$ for $1 \leq i \leq N$, ℓ is a line in $\{x_3 = 0\}$, and V_{H_i} is the multiplicity one varifold associated to H_i . By $\Theta(\mathcal{C}, 0) \in [1, 2)$ and by stationarity of \mathcal{C} , we either have that $\Theta(\Sigma, 0) = 1$ or that $\Theta(\Sigma, 0) = 3/2$. In the former case, $\mathcal{C} = V_{P'}$ where P' is plane and in the latter $\mathcal{C} = V_{Y'}$ where Y' is a rotation of Y whose spine is ℓ . If $\Theta(\Sigma, 0) = 1$, then, by Allard's regularity theorem [All72], Σ is smooth at 0 and the proof is concluded. If $\Theta(\Sigma, 0) = 3/2$, then it follows from [Sim93, Corollary 3 in Section 1, Remark 2 in Section 7] that \mathcal{C} is the unique tangent cone at 0 to V_Σ and, in fact, Σ has the structure of a Y -surface in a neighborhood of 0. \square

We next prove a kind of unique continuation result for minimal Plateau surfaces lying on one side of a regular minimal surface. This is slightly subtle as the usual unique continuation principle does not directly hold for minimal Plateau surfaces.

Lemma 2.2 (Unique continuation for minimal Plateau surfaces). *Let $U \subset \mathbb{R}^3$ be open, $Q = \{q_1, \dots, q_N\}$ be a finite set of points in U , Σ_1 be a connected, (relatively) closed set in U and assume that $\Sigma_1 \setminus Q$ is a minimal Plateau surface without boundary in $U \setminus Q$ with $\bar{\Theta}(\Sigma_1, q) < 2$ for each $q \in Q$. Suppose there is an open subset $V \subset U$ so that $\Sigma_2 \subset U \cap \partial V$ is a regular minimal surface without boundary. If $V \cap \Sigma_1 = \emptyset$ and there is a point $p_0 \in \Sigma_1 \cap \Sigma_2$, then $\Sigma_1 \subset \Sigma_2$. If Σ_2 is connected, then $\Sigma_1 = \Sigma_2$.*

Proof. By throwing out points of Q if needed, we may assume Σ_1 is not a regular minimal surface in a neighborhood of any point of Q . Set $\Gamma = \Sigma_1 \cap \Sigma_2$. We claim

$$(2.5) \quad (Q \cup \text{sing}(\Sigma_1 \setminus Q)) \cap \Gamma = \emptyset.$$

Indeed, as in step one of the proof of Lemma 2.1, the multiplicity one varifold V_{Σ_1} defined by Σ_1 is stationary in U . If $q \in \Gamma$, then as Σ_2 is smooth and $\Sigma_2 = \partial V$, there is an open half-space H so $T_q \Sigma_2 = P = \partial H = T_q V$. As $\Sigma_1 \cap V = \emptyset$, any tangent cone, \mathcal{C} , to V_{Σ_1} at q has support disjoint from H and, because Σ_1 is connected, $\Theta(\Sigma, q) \geq 1$ and so \mathcal{C} is non-trivial. As \mathcal{C} is a stationary integer multiplicity cone with density strictly less than 2, this implies that $\mathcal{C} = V_P$. Hence, by Allard's theorem [All72], q is a regular point of V_{Σ_1} , and so $q \notin Q \cup \text{sing}(\Sigma_1 \setminus Q)$.

In particular, by (2.5), $\Sigma_2 \cap \text{int}(\Sigma_1 \setminus Q) = \Gamma$. Hence, for any $q \in \Gamma$ there is an $r > 0$ so $\Sigma'_1 = B_r(q) \cap \Sigma_1$ and $\Sigma'_2 = B_r(q) \cap \Sigma_2$ are connected regular minimal surfaces with Σ'_1 lying on one side of Σ'_2 and $q \in \Sigma'_1 \cap \Sigma'_2$. The strong maximum principle immediately implies $\Sigma'_1 = \Sigma'_2 \subset \Gamma$, i.e., Γ is an open subset of Σ_1 . As Γ is also clearly a closed subset of Σ_1 and $p_0 \in \Gamma$, the connectedness of Σ_1 implies $\Sigma_1 = \Gamma \subset \Sigma_2$. Likewise, $\Sigma_1 = \Gamma$ is an open and closed subset of Σ_2 , proving the last claim. \square

Finally, we observe that there is an injective map from the cells of the tangent cone at a non-boundary point of a cellular minimal Plateau surface to its own cells.

Lemma 2.3. *Let $U \subset \mathbb{R}^3$ be open and $\Sigma \subset U$ be minimal Plateau surface without boundary in U that is cellular in U . For each $p \in \Sigma$, $T_p \Sigma$ is cellular in \mathbb{R}^3 . Moreover, there is a well defined injective map*

$$\mathcal{I}_p : \mathcal{C}(T_p \Sigma) = \{W^j\}_{j=1}^M \rightarrow \mathcal{C}(\Sigma) = \{U^i\}_{i=1}^N$$

defined by $\mathcal{I}_p(W^j) = U^{i_j}$ when and only when

$$W^j = \lim_{\rho \rightarrow 0} \rho^{-1}(U^{i_j} - p),$$

where the convergence occurs in $L^1_{\text{loc}}(\mathbb{R}^3)$ for the corresponding indicator functions.

Proof. By inspection, P, Y and T are cellular in \mathbb{R}^3 with two, three, and four cells respectively. Hence, each $T_p \Sigma$ is cellular in \mathbb{R}^3 . By the definition of minimal Plateau surface, there exist an $r > 0$ and a $C^{1,\alpha}$ -diffeomorphism $\phi : B_r(p) \rightarrow \mathbb{R}^3$ such that $\phi(p) = 0$, $D\phi_p = I$, the identity map and $\phi(B_r(p) \cap \Sigma) = T_p \Sigma$. In particular, there is a $0 < r_1 < r$ so for $0 < r' < r_1$, $B_{\frac{1}{2}r'}(0) \subset \phi(B_{r'}(p)) \subset B_{2r'}(0)$. Moreover, one has $\mathcal{I}_p(W^j) = U^{i_j}$ if and only if, for any $0 < r' < r$, $W^j \cap B_{\frac{1}{2}r'}(0) \subset \phi(U^{i_j} \cap B_{r'}(p))$.

It remains only to show \mathcal{I}_p is injective. As Σ defines a cell structure in U , there is a $\rho > 0$ so that $B_\rho(p) \subset U$ and, for every $0 < \rho' < \rho$, $B_{\rho'}(p) \cap U^i$ is connected. Let $r_2 = \frac{1}{2} \min\{r_1, \rho\}$. Now suppose $\mathcal{I}_p(W^j) = U^{i_j} = \mathcal{I}_p(W^k)$. As observed, this means $(W^j \cup W^k) \cap B_{\frac{1}{2}r_2}(0) \subset \phi(U^{i_j} \cap B_{r_2}(p))$. As $U^{i_j} \cap B_{r_2}(p)$ is connected, so is $\phi(U^{i_j} \cap B_{r_2}(p)) \subset \mathbb{R}^3 \setminus T_p \Sigma$ and so it must be that $W^j = W^k$ and so \mathcal{I}_p is injective. \square

2.2. Reflection symmetry. An important technical consequence of the unique continuation result, Lemma 2.2, and the Hopf maximum principle is that, under suitably hypotheses, an infinitesimal symmetry of a minimal Plateau surface (assumption (4) in Lemma 2.4 below) extends to a global symmetry (the conclusion $R_0(\Sigma^+) \subset \Sigma$ in the same lemma). In order to state this precisely, it is helpful to

recall some additional notation from [Sch83]. First let R_t denote the reflection map through $\{x_3 = t\}$, so that

$$R_t(\mathbf{y}, x_3) = (\mathbf{y}, 2t - x_3).$$

If $\Sigma \subset \mathbb{R}^3$ and $t \in \mathbb{R}$, we let

$$\Sigma_{t^+} = \Sigma \cap \{x_3 \geq t\} \text{ and } \Sigma_{t^+}^\circ = \Sigma \cap \{x_3 > t\}.$$

Similarly, let

$$\Sigma_{t^-} = \Sigma \cap \{x_3 \leq t\} \text{ and } \Sigma_{t^-}^\circ = \Sigma \cap \{x_3 < t\}.$$

Observe that, due to the possible presence of a floating disk in $\{x_3 = t\}$, one may have $\Sigma_{t^\pm}^\circ \subsetneq \bar{\Sigma}_{t^\pm}^\circ \subsetneq \Sigma_{t^\pm}$, where $\bar{\Sigma}_{t^+}^\circ$ is the closure of $\Sigma_{t^+}^\circ$.

Lemma 2.4. *Let U be an open set so that $R_0(U) \subset U$ and let $Q \subset U \cap \{x_3 < 0\}$ be a finite set of points. Suppose $\Sigma \subset U$ is a closed set so $\Sigma \setminus Q$ is a minimal Plateau surface without boundary in U and $\bar{\Theta}(\Sigma, q) < 2$ for all $q \in Q$. If Σ^+ is a component of $\Sigma_{0^+}^\circ$ and V is an open subset of $U \cap \{x_3 > 0\}$ so that:*

- (1) Σ^+ is a connected regular minimal surface in $\{x_3 > 0\}$;
- (2) $\Sigma^+ \subset \partial V$ in $U \cap \{x_3 > 0\}$;
- (3) $R_0(V) \cap \Sigma = \emptyset$;
- (4) There is a $p \in \{x_3 = 0\} \cap \bar{\Sigma}^+$ so that $R_0(T_p\Sigma) = T_p\Sigma$ and $T_p\Sigma \neq \{x_3 = 0\}$,

then $R_0(\Sigma^+) \subset \Sigma$.

Proof. First observe that if Σ is regular at p , then (4) implies that $T_p\Sigma$ is a plane orthogonal to $\{x_3 = 0\}$, i.e., a vertical plane. Likewise, if p is a singular point, then $T_p\Sigma$ is a Y whose spine, ℓ , lies in $\{x_3 = 0\}$ and so that one of the half-planes making up $Y \setminus \ell$ is contained in $\{x_3 = 0\}$. Hence, up to rotating around the x_3 -axis, which leaves all hypotheses unchanged, we may assume $T_p\Sigma$ is $\{x_1 = 0\}$ in the regular case, or $T_p\Sigma = H_0 \cup H_{120} \cup H_{-120}$ in the singular case. We first prove that Σ is locally symmetric near p . That is, there is a $R > 0$ so that $R_0(\Sigma^+) \cap B_R(p) \subset \Sigma$.

Local symmetry in the regular case: As $T_p\Sigma = \{x_1 = 0\}$, there is a radius $r > 0$ so that $B_{2r}(p) \cap \Sigma$ is a smooth surface and there is a solution to the minimal surface equation $u : D_r = \{(0, s, t) : s^2 + t^2 < r^2\} \rightarrow \mathbb{R}$ so that $u(0) = 0$, $\nabla u(0) = 0$ and

$$\Sigma \cap B_{r/2}(p) \subset \{(x_1(p) + u(s, t), x_2(p) + s, x_3 + t) : (s, t) \in D_r\} \subset \Sigma \cap B_{2r}(p).$$

Let $V_- = D_r \cap \{x_3 \leq 0\}$ be the closed half-disk. Set $v_- = u|_{V_-}$ and $v_+ = (u \circ R_0)|_{V_-}$. Clearly, v_\pm satisfy the minimal surface equation on V_- , $v_\pm(0) = 0$ and $\nabla v_\pm(0) = 0$. Up to rotation around the x_3 -axis by 180° , condition (2) and (3) imply that $v_+ \geq v_-$ on V_- . In particular, up to shrinking r , $w = v_+ - v_-$ is a non-negative solution to a uniformly elliptic equation on V_- with $w(0) = 0$ and $\nabla w(0) = 0$ and so, by the Hopf maximum principle, $v_- \equiv v_+$ on V_- and so claim holds with $R = r/2$.

Local symmetry in the singular case: In this case $T_p\Sigma = H_0 \cup H_{120} \cup H_{-120}$ and there exist $r > 0$, so that $\Sigma \cap B_{2r}(p)$ is a Y -surface. Indeed, by taking r small enough there are two $C^{1,\alpha}$ -domains with boundary $V_\pm \subset D_r = \{(0, s, t) : s^2 + t^2 < r^2\} \subset \{x_1 = 0\}$ so that $D_r = V_+ \cup V_-$ and

$$\{(0, 0, \pm t) : t \in (0, r)\} \subset V_\pm, \quad \eta = D_r \cap \partial V_+ \cap \partial V_- \text{ is a } C^{1,\alpha} \text{ curve,}$$

and two smooth solutions to the minimal surface equation $u_\pm : V_\pm \rightarrow \mathbb{R}$ so

$$(2.6) \quad u_\pm(0) = 0, \quad u_+|_\eta = u_-|_\eta, \quad \nabla u_\pm(0) = (0, \mp\sqrt{3})$$

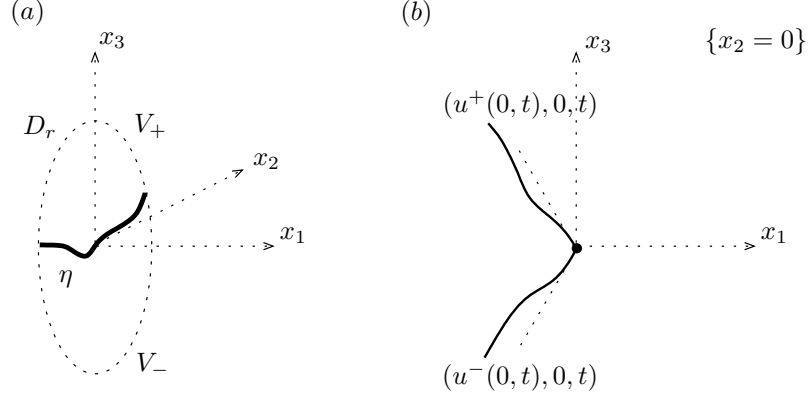

FIGURE 4. A visualization of the case $T_p\Sigma = H_0 \cup H_{120} \cup H_{-120}$. In a neighborhood of p , Σ contains two minimal graphs **in the x_1 -direction**, defined over complementary subdomains V^\pm of a disk. The graphs meet along a $C^{1,\alpha}$ -curve, and form a 120° angle at p : (a) the domains of the two graphs which are subsets of a disk $D_r \subset \{x_1 = 0\}$ centered at 0; (b) a cross section by $\{x_2 = 0\}$ stresses the angle condition.

and

$$\Sigma \cap B_{r/2}(p) \subset \left\{ (x_1(p) + u_\pm(s, t), x_2(p) + s, x_3(p) + t) : (s, t) \in V_\pm \right\} \subset \Sigma;$$

see Figure 4. By hypothesis (1), Σ is regular in $\{x_3 > 0\}$ and so $V_- \subset R_0(V_+)$ and so $v_+ = (u_+ \circ R_0)|_{V_-}$ is defined on the same domain, V_- , as $v_- = u_-$.

Clearly, (2) and (3) imply either that $v_+ \geq v_-$ on V_- or $v_- \geq v_+$. Indeed, the former occurs if

$$\left\{ (x_1(p) + z, x_2(p) + s, x_3(p) + t) : (s, t) \in V_+, u_+(s, t) < z \right\} \cap B_r(p) \subset V$$

and the later occurs when

$$\left\{ (x_1(p) + z, x_2(p) + s, x_3(p) + t) : (s, t) \in V_+, u_+(s, t) > z \right\} \cap B_r(p) \subset V.$$

We assume $v_+ \geq v_-$, the proof is the same in the other case. Observe (2.6) implies $v_+(0) = v_-(0) = 0$ and $\nabla v_+(0) = \nabla v_-(0)$. As v_- and v_+ both satisfy the minimal surface equation on V_- , up to shrinking r , $w = v_+ - v_- \geq 0$ satisfies a uniformly elliptic equation on V_- . As $w(0) = 0$ and $\nabla w(0) = 0$, the Hopf maximum principle for $C^{1,\alpha}$ domains – see [Ros19] – implies $w \equiv 0$, that is, $u_+ \circ R_0 = u_-$ on V_- . Hence, the claim holds with $R = r/2$.

Propagating the symmetry. Finally, we apply Lemma 2.2 to propagate the inclusion $R_0(\Sigma_+) \cap B_R(p) \subset \Sigma$ to $R_0(\Sigma^+) \subset \Sigma$. Let Σ_1 be the component of Σ_{0-}° whose closure contains p – such a component exists and is unique as $T_p\Sigma \cap \{x_3 < 0\}$ is connected and non-empty. Set $\Sigma_2 = R_0(\Sigma^+ \cap \{x_3 > 0\})$, so that, in $U' = U \cap \{x_3 < 0\}$,

$$\Sigma_2 = R_0(\Sigma^+) \subset \partial(R_0(V))$$

and by hypothesis (3), $R_0(V) \cap \Sigma_1 = \emptyset$. As $B_R(p) \cap \Sigma_1 = B_R(p) \cap \Sigma_2$ and both Σ_1 and Σ_2 are connected, Lemma 2.2 implies $R_0(\Sigma^+) = \Sigma_2 = \Sigma_1 \subset \Sigma$. \square

2.3. The moving planes argument. We now prove the key technical result of the paper: Let Σ be a minimal Plateau surface in a convex cylinder C_Ω whose boundary B is contained in the boundary of the cylinder. If B_{0+} is a graph of locally bounded slope and B is “ordered by reflection with respect to the plane $\{x_3 = 0\}$ ” (assumption (b) below), then the same holds for Σ , i.e., Σ_{0+} is a graph of locally bounded slope, and Σ is ordered by reflection, see conclusions (i) and (ii) of Theorem 2.5.

In order to state this result concisely we recall the following partial order from [Sch83]. For subsets $A, B \subset \mathbb{R}^3$ we write

$$A \leq B$$

if $\pi(A) = \pi(B)$, and if $(\mathbf{y}, t) \in \pi^{-1}(\mathbf{y}) \cap A$ and $(\mathbf{y}, t') \in \pi^{-1}(\mathbf{y}) \cap B$ implies $t \leq t'$. Here, as in the previous section, $\pi(\mathbf{y}, t) = \mathbf{y}$ for every $(\mathbf{y}, t) \in \mathbb{R}^3$.

Theorem 2.5. *Let $\Omega \subset \mathbb{R}^2$ be a bounded, open convex set with C^1 -boundary, and let the open cylinder over Ω be denoted by*

$$C_\Omega = \{(\mathbf{y}, x_3) : \mathbf{y} \in \Omega\} .$$

Let $\Sigma \subset \mathbb{R}^3$ be a compact set without isolated points and let $B \subset \partial C_\Omega$ be a closed, non-empty, one-dimensional C^1 -submanifold (not necessarily connected). Suppose that B and Σ satisfy the following:

- (a) B_{0+} is a graph of locally bounded slope and $T_p B$ is not vertical for any $p \in B \cap \{x_3 > 0\}$;
- (b) $B_{0-} \leq R_0(B_{0+})$;
- (c) $(\partial C_\Omega)_{0+} \setminus B_{0+}$ has two connected components, denoted by V^0 and V^1 ;
- (d) $\Sigma \setminus Q$ is a minimal Plateau surface in $\mathbb{R}^3 \setminus Q$, where $Q = \{q_1, \dots, q_M\}$ is a finite subset of C_Ω and, for every i , $\bar{\Theta}(\Sigma, q_i) < 2$;
- (e) $\partial(\Sigma \setminus Q) = B$ and $\Sigma \setminus B \subset C_\Omega$;
- (f) $\Sigma \setminus Q$ defines a cell structure $\{U^i\}_{i=0}^N$ in $C_\Omega \setminus Q$, and for $i = 0, 1$ we have

$$\bar{V}^i = \partial U^i \cap (\partial C_\Omega)_{0+} ;$$

see Figure 5. Then

- (i) Σ_{0+} is a graph with locally bounded slope;
- (ii) $\Sigma_{0-} \leq R_0(\Sigma_{0+})$;
- (iii) there is $\epsilon > 0$ so that $\Sigma \cap \{x_3 > -\epsilon\}$ is a minimal Plateau surface in $\{x_3 > -\epsilon\}$.

Theorem 2.5, whose proof is presented below, has the following corollary:

Corollary 2.6. *Let Ω , B , and Σ satisfy the assumptions in Theorem 2.5, but replace assumptions (b), (c) and (f) with*

- (b') $B_{0-} = R_0(B_{0+})$;
- (c') $(\partial C_\Omega)_{0\pm} \setminus B_{0\pm}$ has two connected components, denoted by $V^{0,\pm}$ and $V^{1,\pm}$;
- (f') $\Sigma \setminus Q$ defines a cell structure $\mathcal{C} = \{U^i\}_{i=0}^N$ in $C_\Omega \setminus Q$ and there are cells $U^{i,\pm} \in \mathcal{C}$ so that

$$\bar{V}^{i,\pm} = \partial U^{i,\pm} \cap (\partial C_\Omega)_{0\pm}, \quad i = 0, 1,$$

here $U^{i,+}$ and $U^{i,-}$ are not necessarily distinct elements of \mathcal{C} .

Then $R_0(\Sigma_{0+}) = \Sigma_{0-}$ and Σ is a minimal Plateau bi-graph.

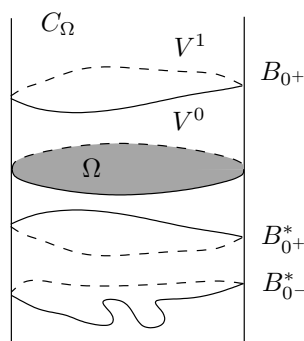

FIGURE 5. The situation in Theorem 2.5. We consider a C^1 -boundary data B contained in $\partial C_\Omega = (\partial\Omega) \times \mathbb{R}$. The “upper part” B_{0+} of B is a graph with bounded slope over $\partial\Omega$, and, after reflection by $\{x_3 = 0\}$, it lies above the “lower part” B_{0-} of B (which is not required to be a graph). The upper part of ∂C_Ω is divided by B_{0+} into two components V^0 and V^1 . We consider a minimal Plateau surface with boundary Σ . If $\partial\Sigma$ is bounded by B in such a way that V^0 and V^1 corresponds to the boundaries of the cells U^0 and U^1 defined by Σ in C_Ω , then the theorem ensures that properties (a) and (b) of B are “transferred” to Σ , see (i) and (ii).

Proof. Thanks to assumptions (b’), (c’) and (f’), we can apply Theorem 2.5 to both Σ and $R_0(\Sigma)$, and so, by conclusion (i), it is true that Σ_{0+} and $(R_0(\Sigma))_{0+} = R_0(\Sigma_{0-})$ are graphs of locally bounded slope. Furthermore, conclusion (ii) implies

$$\Sigma_{0-} \leq R_0(\Sigma_{0+}) \text{ and } R_0(\Sigma_{0+}) = (R_0(\Sigma))_{0-} \leq R_0((R_0(\Sigma))_{0+}) = \Sigma_{0-}.$$

Hence, $R_0(\Sigma_{0+}) = \Sigma_{0-}$ and so $\Sigma = R_0(\Sigma)$. By conclusion (iii) of Theorem 2.5, Σ and $R_0(\Sigma)$ are both minimal Plateau surfaces in $\{x_3 > -\epsilon\}$ for some $\epsilon > 0$, and so Σ is a minimal Plateau surface in \mathbb{R}^3 . Finally, as $\Sigma_{0-} = R_0(\Sigma_{0+})$ and Σ_{0+} are both graphs of locally bounded slope and $\text{sing}(\Sigma) \subset \{x_3 = 0\}$, Σ is a minimal Plateau bi-graph. \square

Proof of Theorem 2.5. First observe that, by deleting points from Q , we may assume that Σ is not a minimal Plateau surface in a neighborhood of any $q \in Q$. That is, the points of Q are essential singularities of Σ . We define

$$\text{sing}(\Sigma) = \text{sing}(\Sigma \setminus Q) \cup Q,$$

where $\text{sing}(\Sigma \setminus Q)$ is the singular set of $\Sigma \setminus Q$ as a minimal Plateau surface in $C_\Omega \setminus Q$. Similarly, let

$$\text{reg}(\Sigma) = \Sigma \setminus \text{sing}(\Sigma), \quad \text{int}(\Sigma) = \Sigma \setminus (B \cup \text{sing}(\Sigma)).$$

Step one: We establish some elementary facts. First, we claim,

$$T_+ = \max \{x_3(p) : p \in B\} > 0 > T_- = \min \{x_3(p) : p \in B\}.$$

Indeed, as B is non-empty, either B_{0+} or B_{0-} is non-empty. Furthermore, $R_0(B_{0+}) \geq B_{0-}$ requires that $\pi(B_{0+}) = \pi(B_{0-})$ and so both B_{0+} and B_{0-} are non-empty. In particular, both T_+ and T_- are finite. Clearly, $T_+ \geq 0$. If $T_+ = 0$, then $(\partial C_\Omega)_{0+} \setminus B_{0+}$ has one connected component in $(\partial C_\Omega)_{0+}$, contradicting assumption (c) and so $T_+ > 0$, and because assumption (b) implies $T_- \leq -T_+$ we conclude that $T_- < 0$.

Secondly, by the same argument used in step one of the proof of Lemma 2.1, the multiplicity one varifold V_Σ defined by Σ is stationary in $\mathbb{R}^3 \setminus B$. Hence, the convex hull property of V_Σ and the properties of B imply

$$(2.7) \quad \Sigma \subset \overline{C_\Omega} \cap \{T_- \leq x_3 \leq T_+\}.$$

Finally, we review assumption (f): $\Sigma \setminus Q$ defines a cell structure $\mathcal{C}(\Sigma) = \{U^i\}_{i=0}^N$ in $C_\Omega \setminus Q$, so that the sets U^i are open and connected, with

$$(2.8) \quad \partial(\Sigma \setminus Q) \subset \partial(C_\Omega \setminus Q), \quad C_\Omega \setminus (\Sigma \cup Q) = (C_\Omega \setminus Q) \setminus (\Sigma \setminus Q) = \bigcup_{i=0}^N U^i,$$

and $\partial U^i \cap \partial C_\Omega = \bar{V}^i$ for $i = 0, 1$. As Σ is compact and C_Ω has two components at infinity, corresponding to $x_3 \rightarrow \pm\infty$ there is exactly one unbounded component of $\mathcal{C}(\Sigma)$ that contains points p with $x_3(p) > T_+$. Up to a swapping V^0 and V^1 , we may assume U^1 is this component and so V^1 is unbounded.

Step two: We verify that the theorem holds in the ‘‘trivial case’’ where

$$(2.9) \quad \bar{\Omega} \times \{T_+\} \text{ is a connected component of } \Sigma.$$

Indeed, if this occurs, than the definition of minimal Plateau surface implies that there is a $\delta > 0$ so that $\Sigma = \bar{\Omega} \times \{T_+\}$ in the slab $\{T_+ - \delta < x_3 < T_+ + \delta\}$. In particular, $\partial\Sigma = \partial\Omega \times \{T_+\}$ in this slab. As $\partial\Omega \times \{T_+\}$ is a graph, assumption (a) implies $B_{0+} = \partial\Omega \times \{T_+\}$. Hence, as a Σ cannot have a connected component without boundary points, we conclude that

$$(2.10) \quad \Sigma_{0+} = \bar{\Omega} \times \{T_+\}.$$

Conclusion (i) is thus immediate. By assumption (e) we have

$$(\partial\Omega) \times \{T_+\} = (\partial\Sigma) \cap \{x_3 > 0\} = B \cap \{x_3 > 0\} = B_{0+} \cap \{x_3 > 0\}$$

so that assumption (b) gives $B_{0-} \leq (\partial\Omega) \times \{-T_+\}$. In particular, Σ_{0-} is a minimal Plateau surface without boundary in $\{x_3 > -T_+\} \setminus Q$ and so the varifold $V_{\Sigma_{0-}}$ defined by Σ_{0-} is stationary in $\mathbb{R}^3 \setminus B_{0-}$. Hence, the convex hull property implies,

$$\Sigma_{0-} \subset \bar{\Omega} \times (-\infty, -T_+],$$

which implies conclusion (ii). Finally, by (ii) and (2.10) it follows that $\Sigma \cap \{x_3 > -T_+\} = \bar{\Omega} \times \{T_+\}$, so that conclusion (iii) holds. Having proved the theorem when (2.9) holds, we will henceforth assume that (2.9) *does not hold*.

Step three: Begin the moving planes argument. For $t \in (0, T_+)$ and $U^i \in \mathcal{C}(\Sigma)$, let

$$A^i = U^i \cap \{x_3 < T_+\}$$

see Figure 6. Let us consider the set of heights

$$G = \{t \in (0, T_+) : \text{properties (P1)–(P5) hold for } t\},$$

where the properties defining G are:

- (P1) $\Sigma \cap \{x_3 = t\}$ is a subset of $\text{reg}(\Sigma)$;
- (P2) $|\nabla_\Sigma x_3| < 1$ on $\Sigma \cap \{x_3 = t\}$;
- (P3) $\overline{R_t(\Sigma_{t+})}$ and Σ_{t+} are graphs with locally bounded slope over $\Omega_t = \pi(\Sigma_{t+})$;
- (P4) $\overline{R_t(A_{t+}^0)} \cap \{x_3 < t\} \cap C_\Omega \subset U^0$;
- (P5) The only cells of \mathcal{C} whose closures meet $\{x_3 = t\}$ are U^0 and U^1 .

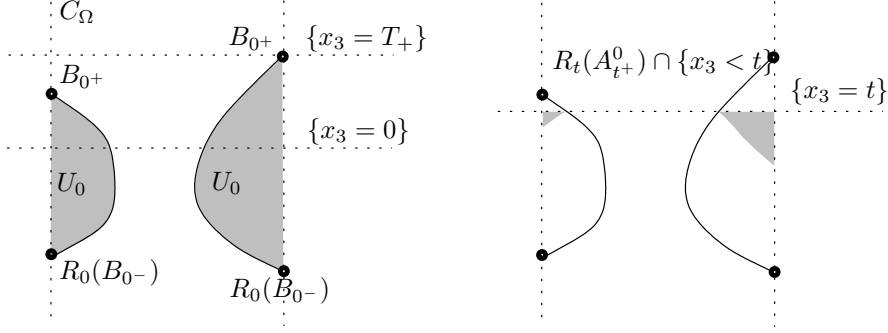

FIGURE 6. Illustration of (P5). The set $R_t(A_{t+}^0) \cap \{x_3 < t\}$, depicted in grey on the right, is contained in U^0 .

We claim that $G = (0, T_+)$. To prove this, we show that

$$(2.11) \quad \exists t_0 \in (0, T_+) \text{ such that } (t_0, T_+) \subset G,$$

and then prove that one may take $t_0 = 0$.

First of all, keeping in mind we excluded the trivial case (2.9), one has

$$(2.12) \quad \exists t_0 \in (0, T_+) \text{ such that } \begin{cases} \text{(P1) holds for all } t \in [t_0, T_+), \text{ and} \\ 0 < |\nabla_{\Sigma} x_3| < 1 \text{ on } \Sigma_{t_0}^+ \end{cases}$$

To see this we first observe that

$$(2.13) \quad \{x_3 = T_+\} \cap \Sigma \cap C_{\Omega} = \emptyset.$$

Indeed, let $p \in \{x_3 = T_+\} \cap \Sigma \cap C_{\Omega}$, set $U = C_{\Omega}$, $V = C_{\Omega} \cap \{x_3 > T_+\}$, $\Sigma_2 = \Omega \times \{T_+\}$ and denote by Σ_1 the component of $\Sigma \cap C_{\Omega}$ containing p . Lemma 2.2 and (2.7) imply that $p \in \Sigma_1 \cap \Sigma_2$ and so $\Sigma_1 = \Sigma_2 = \Omega \times \{T_+\}$. That is, (2.9) holds, contradicting the assumption made in step two.

By (2.13), $\Sigma \cap \{x_3 = T_+\} \subset B$ and, by definition, Σ is regular in a neighborhood of B , thus, for t_0 closed enough to T_+ , (P1) holds for every $t \in [t_0, T_+)$. In particular,

$$(2.14) \quad Q \cap \{t_0 \leq x_3\} = \emptyset.$$

Now, let $p \in \Sigma \cap \{x_3 = T_+\} \subset B$. If $|\nabla_{\Sigma} x_3|(p) = 0$, then (2.7) and the Hopf maximum principle applied to Σ and $\bar{\Omega} \times \{T_+\}$ imply there is a connected neighborhood, Σ_p , of p in Σ so $\Sigma_p \subset \Sigma \cap \{x_3 = T_+\}$. If Σ_1 is the component of $\Sigma \cap C_{\Omega}$ containing Σ_p and $\Sigma_2 = \Omega \times \{T_+\}$, then $\Sigma_1 \cap \Sigma_2 \neq \emptyset$ and so, arguing as above, (2.9) holds, and a contradiction is reached. Therefore $|\nabla_{\Sigma} x_3| > 0$ on $\Sigma \cap \{x_3 = T_+\}$, and so (2.12) holds for t_0 near enough to T_+ by continuity.

Again, by continuity, to show $|\nabla_{\Sigma} x_3| < 1$ on $\Sigma_{t_0}^+$ for t_0 near to T_+ it is enough to show $|\nabla_{\Sigma} x_3| < 1$ on $\Sigma \cap \{x_3 = T_+\} \subset B$. To show this last fact, let H be a supporting closed half-space to C_{Ω} at p (H is unique as $\partial\Omega$ is C^1 regular), and set $\Pi = \partial H$. By (2.7), $\Sigma \subset H$. Consider the half-space $T_p \Sigma$. By the Hopf maximum principle, if $T_p \Sigma \subset \Pi$, then there is a neighborhood Σ' of p in Σ with $\Sigma' \subset \Pi$. As $\Pi \cap C_{\Omega} = \emptyset$, contradicts assumption (e), i.e., that $\Sigma \setminus B \subset C_{\Omega}$. Hence, $T_p \Sigma \not\subset \Pi$, while $B \subset \partial C_{\Omega}$ implies $T_p B \subset \Pi$. Since $T_p B$ is not vertical (either by assumption (a), or because, in this specific case, it is actually contained into $\{x_3 = T_+\}$, and

thus is horizontal), we conclude that $|\nabla_{\Sigma}x_3|(p) < 1$ and so (2.12) holds. In fact, as we will use later, this argument implies

$$(2.15) \quad |\nabla_{\Sigma}x_3| < 1 \text{ for any } p \in B \cap \{x_3 > 0\}.$$

We now show that, after possibly moving t_0 toward T_+ , (P1)–(P5) hold for $t \in (t_0, T_+)$. Indeed, (2.12), immediately gives a t_0 so (P1) and (P2) hold for every $t \in (t_0, T_+)$. Up to moving t_0 , this implies (P3) holds for $t \in (t_0, T_+)$. In particular,

$$(2.16) \quad \Sigma \cap \{x_3 > t_0\} = \text{graph of a smooth function over } \pi(\Sigma \cap \{x_3 > t_0\}).$$

By (2.8) and (2.14), we have that

$$(2.17) \quad \{x_3 > t_0\} \cap (C_{\Omega} \setminus \Sigma) = \{x_3 > t_0\} \cap \bigcup_{i=0}^N U^i.$$

By the convex hull property, each component of $\{x_3 > t_0\} \cap (\bar{C}_{\Omega} \setminus \Sigma)$ must intersect ∂C_{Ω} . Hence, it follows from assumptions (c) and (f) that $\{x_3 > t_0\} \cap (C_{\Omega} \setminus \Sigma) = \{x_3 > t_0\} \cap (U^0 \cup U^1)$. Hence, as (2.9) does not hold and Σ defines a cell structure in $C_{\Omega} \cap \{x_3 > t_0\}$

$$\begin{aligned} \Sigma_{t_+} &= \partial A_{t_+}^0 \cap \partial A_{t_+}^1, \\ \{T_+ > x_3 > t\} \cap \bar{C}_{\Omega} &= \{T_+ > x_3 > t\} \cap (\Sigma_{t_+} \cup A_{t_+}^0 \cup A_{t_+}^1), \end{aligned}$$

for every $t \in (t_0, T_+)$. This immediately implies, that after moving t_0 toward T_+ by any amount, (P5) holds for $t \in (t_0, T_+)$. Moreover, combining this with (2.12) implies that, possibly up to further moving t_0 toward T_+ , (P4) hold for $t \in (t_0, T_+)$ – see Figure 6.

Step five : We show that $G = (0, T_+)$. Suppose instead that

$$t_1 = \sup \{t < T_+ : t \notin G\} > 0.$$

We prove that $t_1 \notin G$ by showing that $[t_1, T_+) \subset G$ implies the existence of $\delta > 0$ such that $(t_1 - \delta, T_+) \subset G$. By continuity, it is clear that if (P1) and (P2) hold at $t = t_1$, then they hold whenever $|t - t_1| < \delta$ for some $\delta > 0$. The implicit function theorem, the validity of (P1) and (P2) for $|t - t_1| < \delta$ and the fact that (P3) already holds for $t \in [t_1, T_+)$, together imply that, up to decreasing, δ , (P3) holds for $t \in (t_1 - \delta, T)$. Finally, the argument used above to deduce that (P4) and (P5) hold on (t_0, T_+) from the fact that (P1), (P2) and (P3) hold on (t_0, T_+) can be repeated verbatim with $(t_1 - \delta, T_+)$ in place of (t_0, T_+) .

We have thus proved that $t_1 \notin G$: in particular, (P1)–(P5) hold for every $t \in (t_1, T_+)$, but at least one of them fails at $t = t_1 > 0$. We now exclude these five possibilities to reach a contradiction. This will ultimately prove that we cannot have $t_1 > 0$, and thus that $t_1 = 0$ and so $G = (0, T_+)$. First, we show there is no infinitesimal symmetry at $t = t_1$ when $t_1 > 0$.

Proof there is no infinitesimal symmetry at $t = t_1 > 0$: It is true that

$$(2.18) \quad \text{if } t_1 > 0, p \in \Sigma \cap \{x_3 = t_1\} \setminus Q \text{ and } T_p \Sigma \neq \{x_3 = 0\}, \text{ then } R_0(T_p \Sigma) \neq T_p \Sigma.$$

We argue by contradiction and suppose $R_0(T_p \Sigma) = T_p \Sigma$. As $T_p \Sigma \neq \{x_3 = 0\}$, $T_p \Sigma \cap \{x_3 > 0\}$ is non-empty. Hence, there is a component, Σ^+ of $\Sigma_{t_1}^+$ so that $p \in \bar{\Sigma}^+$. As (P1) holds for $t > t_1$, Σ^+ is regular in $\{x_3 > t_1\} \cap C_{\Omega}$. Set $V' =$

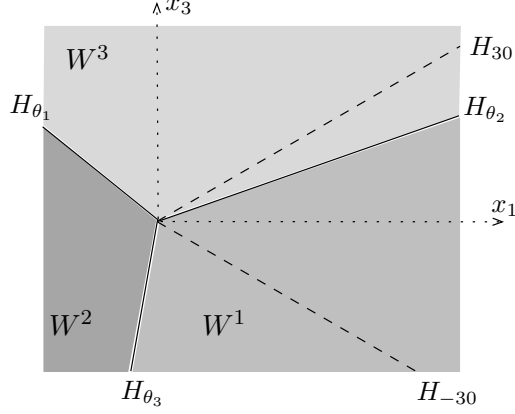

FIGURE 7. The half-plane H_θ is defined by a rotation of $H = H_0 = \{x_3 = 0, x_1 \geq 0\}$ by an angle θ around the x_2 axis, with the convention that H_{θ_2} in this picture corresponds to $\theta_2 > 0$.

$U^0 \cap \{t_1 < x_3 < T_+\} \subset A_{t_+}^0$ so V' is open in $C_\Omega \cap \{x_3 > t_1\}$. As (P4) holds for $t > t_1$, there is a connected component V of V' so that $\Sigma^+ \subset \partial V$ in $C_\Omega \cap \{x_3 > t_1\}$. Moreover, as $V' = \bigcup_{t > t_1} A_{t_+}^0$, the fact that (P5) holds for $t > t_1$ implies $R_{t_1}(V') \subset U^0$ and so $R_{t_1}(V) \cap \Sigma = \emptyset$. That is, the hypotheses of Lemma 2.4 hold in $U = C_\Omega$. Hence,

$$(2.19) \quad R_{t_1}(\Sigma^+) \cap C_\Omega \subset \Sigma \text{ and so, as } \Sigma \text{ is closed, } R_{t_1}(\Sigma^+) \subset \Sigma.$$

By the convex hull principle for stationary varifolds, $B \cap \Sigma^+ \neq \emptyset$ and so there is a $q \in B \cap \Sigma^+$. Observe that as $\Sigma^+ \subset \Sigma_{t_1}^\circ$, $x_3(q) > t_1$. By hypotheses (e), $R_0(\Sigma_+) \cap \partial C_\Omega \subset B$ and so (2.19) implies

$$\{q, R_{t_1}(q)\} \subset \pi^{-1}(\pi(q)) \cap \Sigma \subset B.$$

If $t_1 \geq \frac{1}{2}T_+$ this implies $q, R_{t_1}(q) \in B_{0+}$ contradicting B_{0+} being a graph. If $t_1 \in (0, \frac{1}{2}T_+)$, then $R_{t_1}(q) \in B_{0-}$ and $x_3(R_{t_1}(q)) > x_3(R_0(q))$, a contradiction to $R_0(B_{0+}) \geq B_{0-}$, i.e., (b). From this we conclude that (2.18) holds.

Proof that $t_1 \notin G$ and $t_1 > 0$ imply (P1) holds at $t = t_1$: If (P1) fails at $t = t_1$, then

$$(2.20) \quad \exists p \in \text{sing}(\Sigma) \cap \{x_3 = t_1\}.$$

As $\text{sing}(\Sigma) \cap B = \emptyset$, $t_1 < T_+$, and Q is a finite set of points, there is $R > 0$ such that Σ is a minimal Plateau surface without boundary in $B_R(p) \setminus \{p\}$. Moreover, by (P3) and $(t_1, T_+) \subset G$, one has that $\Sigma \cap B_R \cap \{x_3 > t_1\}$ is a graph of locally bounded slope. Since $\bar{\Theta}(\Sigma, p) < 2$ and $p \in \text{sing}(\Sigma)$, Lemma 2.1 implies that Σ is a minimal Plateau surface in $B_R(p)$ and that p is a Y -point of Σ , with the spine of the tangent Y -cone $T_p\Sigma$ lying in the horizontal plane $\{x_3 = 0\}$. Thus, up to rotating Σ around the x_3 -axis,

$$(2.21) \quad T_p\Sigma = H_{\theta_1} \cup H_{\theta_2} \cup H_{\theta_3}, \text{ where } |\theta_2| \leq 30, \theta_1 = \theta_2 + 120, \theta_3 = \theta_2 - 120;$$

see Figure 7. Let W^3 be the region of $\mathbb{R}^3 \setminus T_p\Sigma$ between H_{θ_1} and H_{θ_2} and likewise let W^2 be the region between H_{θ_1} and H_{θ_3} and W^1 the region between H_{θ_2} and H_{θ_3} . Appealing to Lemma 2.3, let $\mathcal{C}(T_p\Sigma) = \{W^1, W^2, W^3\}$ and let $U^{i_j} = \mathcal{I}_p(W^j)$ be the cells in $\mathcal{C}(\Sigma)$ that correspond to W^j , $j = 1, 2, 3$. By Lemma 2.3, \mathcal{I}_p is injective and so $U^{i_j} \neq U^{i_k}$ for $j \neq k$.

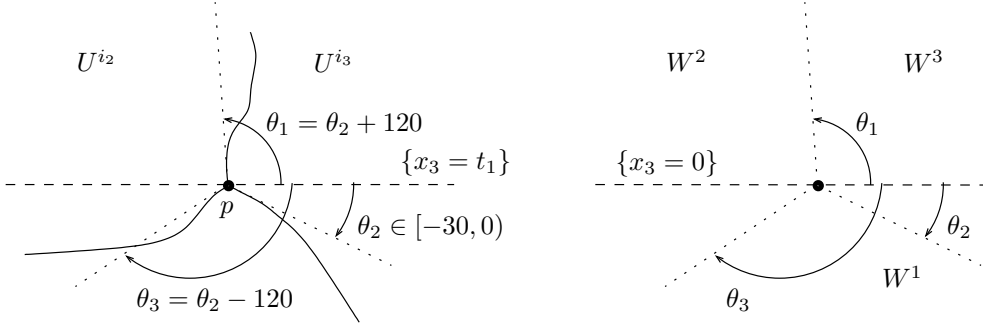

FIGURE 8. The situation, in a sufficiently small ball near p , when $\theta_2 \leq 0$. The validity of $R_t(A_{t_+}^0) \cap \{x_3 < t\} \cap C_\Omega \subset U^0$ for every $t \in (t_1, T_+)$ implies that, if $U^{i_k} = U^0$, then $R_0(W^k) \cap \{x_3 < 0\} \subset W^k$.

We claim $\theta_2 = 0$, $\theta_1 = 120$, $\theta_3 = -120$. Suppose $\theta_2 > 0$. In this case, H_{θ_1} and H_{θ_2} both meet $\{x_3 > 0\}$, and so W^1, W^2 and W^3 all meet $\{x_3 > 0\}$ (this is exactly the situation depicted in Figure 7). As (P5) holds for $t \in (t_1, T_+)$, this means that $\{U^{i_1}, U^{i_2}, U^{i_3}\} = \{U^0, U^1\}$ which is impossible as the three regions must be distinct. Hence, $\theta_2 \leq 0$, see Figure 8. In this case, only W^2 and W^3 intersect $\{x_3 > 0\}$ and so, as (P5) holds for $t \in (t_1, T_+)$, $\{U^{i_2}, U^{i_3}\} = \{U^0, U^1\}$. Thus, there are two cases, (2.22) either $U^{i_2} = U^1$ and $U^{i_3} = U^0$, or $U^{i_2} = U^0$ and $U^{i_3} = U^1$.

The validity of (P4) for $t \in (t_1, T_+)$ implies that either in the first case of (2.22) that $R_0(W^3) \cap \{x_3 < 0\} \subset W^3$ and in the second that $R_0(W^2) \cap \{x_3 < 0\} \subset W^2$. In the first case, $-\theta_1 \geq \theta_2$ while, by (2.21), $\theta_2 + 120 = \theta_1 \leq -\theta_2$ and so $\theta_2 \leq -60$. This contradicts $\theta_2 \in [-30, 0]$ and so does not occur. In the second case, $-\theta_1 \leq \theta_3$, and so combined with (2.21) one has $0 \leq \theta_1 + \theta_3 = 2\theta_2 \leq 0$ and so $2\theta_2 = \theta_1 + \theta_3 = 0$. This verifies the claim that $\theta_2 = 0$, $\theta_1 = -120$, and $\theta_3 = 120$. In particular, $R_0(T_p\Sigma) = T_p\Sigma$, however this contradicts (2.18) and so (P1) holds at $t = t_1$.

Proof that $t_1 \notin G$ and $t_1 > 0$ imply that (P2)–(P5) holds at $t = t_1$: If (P2) does not hold for $t = t_1$, then, by (2.15), there is a point $p \in \{x_3 = t_1\} \cap \Sigma$, $p \notin B$ such that $|\nabla_\Sigma x_3|(p) = 1$ – recall, $\Sigma \cap \{x_3 = t_1\}$ consists of regular points as (P1) has already been established at $t = t_1$. Hence, $T_p\Sigma$ is vertical and so $T_p\Sigma \neq \{x_3 = 0\}$ and $R_0(T_p\Sigma) = T_p\Sigma$. As this contradicts (2.18), (P2) must hold for $t = t_1$. (P3) follows immediately from (P1), (P2) and the fact that (P3) holds for $t > t_1$.

If (P4) holds for $t \in (t_1, T_+)$ but fails at $t = t_1$, one must have that

$$\overline{R_{t_1}(A_{t_1^+}^0)} \cap \{x_3 < t_1\} \cap C_\Omega \subset \overline{U^0},$$

holds but

$$\overline{R_{t_1}(A_{t_1^+}^0)} \cap \{x_3 < t_1\} \cap C_\Omega \subset U^0$$

does not. Therefore, there is $p \in \partial U^0 \cap \partial(R_{t_1}(A_{t_1^+}^0)) \cap \{x_3 < t_1\} \cap C_\Omega$. Since

$$\partial(R_{t_1}(A_{t_1^+}^0)) \cap \{x_3 < t_1\} \subset R_{t_1}(\Sigma_{t_1^+})$$

and (P1) holds for $t \geq t_1$, we see that p is a regular point of $R_{t_1}(\Sigma_{t_1^+})$. However, as $p \in \partial U^0 \cap C_\Omega$, we also have $p \in \Sigma$ and so applying Lemma 2.2, gives $R_{t_1}(\Sigma_{t_1^+}) \subset \Sigma$ and this yields a contradiction as in the proof of (2.18). Hence, (P4) holds at $t = t_1$.

Finally, if (P5) fails for $t = t_1$, we can find U^k with $k \neq 0, 1$ such that $\bar{U}^k \cap \{x_3 = t_1\} \neq \emptyset$. Up to relabeling, we can set $k = 2$, and thus consider the existence of $p \in \bar{U}^2 \cap \{x_3 = t_1\}$. By assumption (c), $\bar{U}^2 \cap (C_\Omega)_{0+} = \emptyset$ and so $p \in C_\Omega$. Moreover, the validity of (P5) for $t > t_1$ implies that $\bar{U}^2 \subset \{x_3 \leq t_1\}$ and so $p \in \partial U^2 \cap C_\Omega \subset \Sigma$. In fact, as (P1) holds at $t = t_1$, $p \in \text{int}(\Sigma)$. Given that Σ agrees with ∂U^2 near p , one has $\nabla_\Sigma x_3(p) = 0$. Hence, the strict maximum principle implies $x_3 = t_1$ on $B_r(p) \cap \Sigma$ for some small $r > 0$. As (P1) is an open condition, there is $\delta > 0$ so that $\Sigma_1 = \Sigma \cap \{x_3 > t_1 - \delta\}$ is a regular minimal surface with boundary in $\{x_3 > t_1 - \delta\} \cap \bar{C}_\Omega$. In particular, we may apply the standard unique continuation principle for smooth minimal surfaces to Σ_1 and the connected surface $\Sigma_2 = \Omega \times \{t_1\}$ to see that $\Sigma_2 \subset \Sigma_1 \subset \Sigma$. This contradicts (2.9) and so conclude (P5) holds at $t = t_1$. Hence, if $t_1 \notin G$ and $t_1 > 0$, then $t_1 \in G$. and so $t_1 = t_0 = 0$ and $G = (0, T_+)$.

Step Six. To conclude the proof we first observe that $G = (0, T_+)$ immediately implies (i) and (ii) hold. We are left to show conclusion (iii), namely the existence of $\epsilon > 0$ so Σ is a minimal Plateau surface in $\{x_3 > -\epsilon\}$. As $G = (0, T_+)$, $\Sigma \cap \{x_3 > 0\}$ is a regular minimal surface with boundary, so we need only check that $Q \cap \{|x_3| < \epsilon\} = \emptyset$ for a suitable $\epsilon > 0$. As Q is a finite set contained in C_Ω , we only need to check that if $p \in \{x_3 = 0\} \cap \Sigma \cap C_\Omega$, then $p \notin Q$. Clearly, there is an $r > 0$ so that Σ is a minimal Plateau surface without boundary in $B_r(p) \setminus \{p\}$. Obviously $\bar{\Theta}(\Sigma, p) < 2$, and since $G = (0, T_+)$, $\Sigma \cap \{x_3 > 0\}$ is a graph of locally bounded slope. By Lemma 2.1, p is either a regular or a Y -point, so it does not belong to Q , as claimed. \square

3. RIGIDITY FOR MINIMAL PLATEAU SURFACES IN A SLAB

In this section we prove the rigidity of minimal Plateau surfaces in a slab with symmetric convex boundary. We begin by proving topological rigidity in Proposition 3.1, which consists in showing that such minimal Plateau surfaces are *simple* bi-graphs. Combined with the previous section and a moving planes argument of Pyo [Pyo12] this will complete the proof Theorem 1.2. This topological rigidity is an extension of an argument of Ros [Ros96] to minimal Plateau surfaces. Note that Ros's argument uses the Lopez-Ros deformation [LR91] and so is special to \mathbb{R}^3 .

Proposition 3.1 (cf. Theorem 1 of [Ros96]). *Let $\Sigma \subset \{|x_3| \leq 1\}$ be a connected minimal Plateau bi-graph with $\partial\Sigma = \Gamma \times \{\pm 1\}$ where $\Gamma \subset \mathbb{R}^2$ is convex. If Σ is symmetric across $\{x_3 = 0\}$ and Σ defines a cell structure in $\{|x_3| < 1\}$, then Σ is simple.*

Proof. Let $\Sigma_+ = \bar{\Sigma}_{0+}^\circ = \overline{\Sigma \cap \{x_3 > 0\}}$. The symmetry of Σ and the fact that it is a bi-graph implies that Σ_+ is a regular minimal surface with boundary whose interior is a graph over $\{x_3 = 0\}$. In particular, as Σ is connected, Σ_+ is a connected planar domain. One readily checks that at the points of $\{x_3 = 0\} \cap \partial\Sigma_+$, Σ either intersect $\{x_3 = 0\}$ orthogonally (if the point is a regular point of Σ) or intersect at an angle of 120° (if the point is a Y -point of Σ). There must exist such points as Σ is connected. In fact, as Σ defines a cell structure in $\{|x_3| < 1\}$ one must have either $\{x_3 = 0\} \cap \Sigma \subset \text{reg}(\Sigma)$ or $\{x_3 = 0\} \cap \Sigma = \text{sing}(\Sigma)$ – see Figure 3-(b). That is, either Σ is regular or every component of $\Sigma_+ \cap \{x_3 = 0\}$ consists of Y -points and bounds a disk in Σ .

If Σ is regular, then this means Σ_+ solves the free boundary Plateau problem for the data $(\Gamma_+, \{x_3 = 0\})$ in the sense of [Ros96] and so is an annulus by [Ros96, Corollary 3]. It immediately follows that Σ is also an annulus and so is simple.

If Σ is singular, then the constant contact angle with $\{x_3 = 0\}$, continues to imply that every non-null homologous loop in Σ_+ has vertical flux. Indeed, let σ be an (oriented) component of $\partial\Sigma_+$ that meets $\{x_3 = 0\}$ at 120° . Let ν_σ is the outward conormal to σ in Σ_+ and let \mathbf{n}_σ be the outward normal to σ in $\{x_3 = 0\}$. Clearly, $\nu_\sigma(p) = -\frac{1}{2}\mathbf{n}_\sigma(p) - \frac{\sqrt{3}}{2}\mathbf{e}_3$ and so,

$$\text{Flux}(\sigma) = \int_\sigma \nu_\sigma d\mathcal{H}^1 = -\frac{1}{2} \int_\Sigma \mathbf{n}_\sigma d\mathcal{H}^1 - \frac{\sqrt{3}}{2} \mathcal{H}^1(\sigma) \mathbf{e}_3 = -\frac{\sqrt{3}}{2} \mathcal{H}^1(\sigma) \mathbf{e}_3$$

where the last equality follows from applying the divergence theorem in $\{x_3 = 0\}$. As any closed curve in Σ_+ is homologous to some linear combination of the components of $\{x_3 = 0\} \cap \partial\Sigma_+$, it follows that Σ_+ has vertical flux for each closed curve.

To complete the proof we use the Lopez-Ros deformation [LR91] to reduce to the regular case. To that end consider the Weierstrass data (M, η, G) of Σ_+ . Here M is the underlying Riemann surface structure of Σ_+ , η is the (holomorphic) height differential (i.e., the complexification of dx_3) and G is the meromorphic function given by the stereographic projection of the Gauss map (of the outward normal). This data produces a conformal embedding of Σ_+ by M

$$\mathbf{F} : M \rightarrow \Sigma^+ \subset \mathbb{R}^3$$

given by

$$\mathbf{F}(p) = \text{Re} \int_p^{p_0} \left(\frac{1}{2}(G^{-1} - G), \frac{i}{2}(G^{-1} + G), 1 \right) \eta.$$

Let ∂_+M be the component of ∂M sent to $\Gamma \times \{1\}$ and let $\partial_-M = \partial M \setminus \partial_+M$ be the components sent to $\Sigma_+ \cap \{x_3 = 0\}$. As Σ_+ meets $\{x_3 = 0\}$ at 120° , one has $|G| = \gamma_0 = \frac{\sqrt{3}}{3} > 0$, is constant on ∂_-M . As observed by Lopez-Ros [LR91], because the flux of Σ_+ is vertical, the Weierstrass data $(M, \eta, \gamma_0^{-1}G)$ produces a conformal immersion $\mathbf{F}' : M \rightarrow \Upsilon_+ \subset \mathbb{R}^3$ of a new (possibly immersed) minimal surface with boundary Υ_+ . The properties of the Lopez-Ros deformation ensure that $\partial\Upsilon_+ \subset \{x_3 = 1\} \cup \{x_3 = 0\}$ and $\mathbf{F}(\partial_+M) = \partial\Upsilon_+ \cap \{x_3 = 1\}$ is convex – see [PR93, Lemma 2] while Υ_+ meets $\{x_3 = 0\}$ orthogonally. It follows that the set $\Upsilon = \Upsilon_+ \cup R_0(\Upsilon_+)$ given by taking the union of Υ_+ with its reflection across $\{x_3 = 0\}$ gives a connected smooth minimal (possibly immersed) surface whose boundaries are convex curves lying on $\{x_3 = \pm 1\}$. By a result of Ekholm, Weinholtz and White [EWW02], Υ is embedded and so Υ_+ solves the free boundary Plateau problem for the data $(\Upsilon_+, \{x_3 = 0\})$ in the sense of [Ros96] and so, as before, is an annulus by [Ros96, Corollary 3]. Hence, Σ_+ is an annulus and so Σ is also simple in the singular case. \square

We are now in a position to prove Theorem 1.2. For brevity we use Proposition 3.1 to allow us to appeal to a result of Pyo [Pyo12] to handle the case where the boundaries are circles, however, one could also work directly with moving planes argument used in [Pyo12] and avoid Proposition 3.1.

Proof of Theorem 1.2. Let $\Omega \subset \mathbb{R}^2$ be the convex open domain so $\Gamma = \partial\Omega$. We first prove that Σ is a simple minimal Plateau bi-graph, which is symmetric by reflection through $\{x_3 = 0\}$. This is immediate if Σ is disconnected. Indeed, in that case, by the convex hull property we find that $\Sigma \subset \{|x_3| = \pm 1\}$, and so $\Sigma = \Omega_- \cup \Omega_+$ where $\Omega_\pm = \Omega \pm \mathbf{e}_3$. We thus assume that Σ is connected, and claim that Σ satisfies the hypotheses of Corollary 2.6 in C_Ω with $B = \Gamma_- \cup \Gamma_+$ and $Q = \emptyset$.

Indeed, the only item that is not immediate is $\Sigma \setminus B \subset C_\Omega$. but this follows from the maximum principle of Solomon-White applied to V_Σ , the varifold associated to Σ , and appropriate catenoidal barriers. Hence, by Corollary 2.6, Σ is a minimal Plateau bi-graph that is symmetric with respect to reflection across $\{x_3 = 0\}$. As Σ is connected we may then appeal to Proposition 3.1 to see that Σ is simple.

Finally, we treat the case that Γ is a circle. To that end, let $\Sigma_+ = \overline{\Sigma} \cap \{x_3 > 0\}$. As already observed this set is a regular minimal annulus with one boundary a circle in the plane $\{x_3 = 1\}$ and the other boundary meeting $\{x_3 = 0\}$ in a constant contact angle (either 90° or 120°). It now follows from the main result of [Pyo12] that Σ_+ is a piece of a catenoid. As such, Σ is either a subset of Cat or of Cat_Y depending on its regularity. \square

4. GLOBAL RIGIDITY OF MINIMAL PLATEAU SURFACES WITH TWO REGULAR ENDS

In this section we prove Theorem 1.4. To do so we first establish certain elementary properties of the ends – specifically that asymptotically they are parallel and have equal, but opposite, logarithmic growth rate – this is entirely analogous to what is done in the regular case. As a consequence, we may appeal to Theorem 2.5 to conclude that Σ is, after rotation and vertical translation, symmetric with respect to reflection across $\{x_3 = 0\}$ and that $\Sigma_+ = \Sigma \cap \{x_3 \geq 0\}$ is a graph of locally bounded slope. We conclude the proof by using complex analytic arguments – specifically a variant of the Lopez-Ros deformation [LR91] – to reduce to the case already considered by Schoen [Sch83]. We remark that one could also adapt the moving planes method with planes orthogonal to $\{x_3 = 0\}$ as is done in [Sch83] and [Pyo12] to give a direct proof of rotational symmetry of Σ_+ that avoids complex analytic methods entirely.

Let $\Sigma \subset \mathbb{R}^3$ be a minimal Plateau surface with two regular ends. In particular, following [Sch83] there is a compact set $K \subset \mathbb{R}^3$ so that

$$\Sigma \setminus K = \Gamma_1 \cup \Gamma_2$$

where there are rotations $S_1, S_2 \in SO(3)$ and a radius $\rho > 0$ so for $i = 1, 2$,

$$S_i \cdot \Gamma_i = \{(\mathbf{y}, u_i(\mathbf{y})) : \mathbf{y} \in \mathbb{R}^2 \setminus \bar{B}_\rho\}$$

and

$$u_i(\mathbf{y}) = a_i \log |\mathbf{y}| + b_i + \mathbf{c}_i \cdot \frac{\mathbf{y}}{|\mathbf{y}|^2} + R_i(\mathbf{y})$$

where

$$|R_i(\mathbf{y})| + |\mathbf{y}| |\nabla R_i(\mathbf{y})| \leq C |\mathbf{y}|^{-2}.$$

Let $P_i = S_i(\{x_3 = 0\})$, be the planes the Γ_i are graphs over. One readily checks that $\lim_{\rho \rightarrow 0} \rho \Gamma_i = P_i$, that is, each Γ_i is asymptotic to the plane P_i .

Lemma 4.1. *One has $\lim_{R \rightarrow \infty} \frac{\mathcal{H}^2(\Sigma \cap B_R)}{\pi R^2} = 2$. In fact, one has $P_1 = P_2 = P$ and $\lim_{\rho \rightarrow 0} \Sigma = P$ in $C_{loc}^\infty(\mathbb{R}^3 \setminus \{0\})$. If Σ is disconnected then $\Gamma = P'_1 \cup P'_2$ where P'_i are disjoint planes parallel to P .*

Proof. It is clear from the definition of regular end that $\lim_{\lambda \rightarrow 0} \lambda \Sigma = P_1 \cup P_2$ in $C^1(\mathbb{R}^3 \setminus \{0\})$. This proves the first claim. Suppose that $P_1 \neq P_2$ as both P_1 and P_2 are planes through the origin this means that there is a point $q \in \partial B_2 \cap P_1 \cap P_2$ so that $D_i = B_1(q) \cap P_i$ are two disks that meet transversely along a line segment. The

convergence of $\rho\Gamma_i$ to P_i as $\rho \rightarrow 0$. Implies that for ρ very small $D'_i(\rho) = \rho\Gamma_i \cap B_1(q)$ is a graph over D_i with small C^1 norm and so $D'_1(\rho)$ meets $D'_2(\rho)$ transversely along a curve in small tubular neighborhood of $D_1 \cap D_2$. This means that $\rho\Sigma$ is not a Plateau surface in B_1 (as the infinitesimal model is the transverse union of two planes) and so this cannot occur under the hypotheses of Theorem 1.4. Hence, $P_1 = P_2 = P$. The nature of the convergence and standard elliptic regularity implies the convergence may be taken in $C_{loc}^\infty(\mathbb{R}^3 \setminus \{0\})$.

Finally, if Σ is disconnected, then, as there are no compact minimal Plateau surfaces without boundary, there are exactly two connected components, Σ_1 and Σ_2 of Σ corresponding to the ends Γ_1 and Γ_2 . Clearly, each Σ_i is a minimal Plateau surface and $\lim_{\rho \rightarrow 0} \Sigma_i = P_i = P$. By the monotonicity formula this implies each Σ_i is a plane that is parallel to P by definition. \square

Proof of Theorem 1.4. If Σ is disconnected, then Lemma 4.1 implies Σ is a pair of disjoint parallel planes and we are done. If $\text{sing}(\Sigma) = \emptyset$, then Σ is a smooth minimal surface and so [Sch83] applies and we are also done. As such we may assume Σ is connected and $\text{sing}(\Sigma) \neq \emptyset$. In this case up to an ambient rotation we may assume the the unique tangent plane at infinity, P , given by Lemma 4.1 is $P = \{x_3 = 0\}$. Let u_i be the functions with the given asymptotics for the ends Γ_i . Note that even though $P_1 = P_2 = P$, there is still a freedom in the choice of the rotations S_i . For concreteness, choose the same rotation for both ends. As a consequence, by vertically translating Σ appropriately, we may assume $b_1 + b_2 = 0$.

It follows from standard calculations (e.g., those in [Sch83]) that the flux of each Γ_i is vertical. In fact, if σ_i is an appropriately oriented choice of generator for the homology of the annulus Γ_i , then

$$\text{Flux}(\sigma_i) = \int_{\sigma_i} \nu_{\sigma_i} d\mathcal{H}^1 = 2\pi a_i \mathbf{e}_3.$$

Hence, by the balancing properties of the flux – which hold for minimal Plateau surfaces as they follow from (2.2) – one has $2\pi a_1 + 2\pi a_2 = 0$. Up to relabelling, one may assume $a_1 \geq 0 \geq a_2 = -a_1$. In fact, by the strong half-space theorem [HMI90], $a_1 > 0 > a_2 = -a_1$.

Take $R > 1$ large and let $\Sigma_R = \Sigma \cap \bar{C}_R$ be the closed cylinder of radius R centered on the x_3 -axis. Our assumptions on Σ and the properties of the ends imply that, for any $\epsilon > 0$, there is an $R_\epsilon > 0$ large so that, for $R > R_\epsilon$, $\Sigma_R - \epsilon\mathbf{e}_3$ satisfies the hypotheses of Theorem 2.5. It follows that $\Sigma \cap \{x_3 > \epsilon\}$ and $\Sigma \cap \{x_3 < -\epsilon\}$ are both graphs over the plane $\{x_3 = 0\}$ and each is ϵ close to reflection across $\{x_3 = 0\}$ of the other. Taking $\epsilon \rightarrow 0$, it follows that $\Sigma \setminus \{x_3 = 0\}$ consists of two graphical components and is symmetric with respect to reflection across $\{x_3 = 0\}$.

To complete the proof one considers $\Sigma_+ = \bar{\Sigma} \cap \{x_3 > 0\}$. As $\text{sing}(\Sigma) \neq \emptyset$, Σ_+ is a surface with one catenoidal end that meets $\{x_3 = 0\}$ along one boundary curve with constant contact angle equal to 120° . Observe that as Σ_+ has a catenoidal end, the underlying Riemann surface structure of Σ_+ is $M \setminus \{p_0\}$ where M is a compact Riemann surface with boundary and $p_0 \notin \partial M$. Let $(M \setminus \{p_0\}, \eta, G)$ be Weierstrass data for Σ_+ so η , is the height differential, and G , the stereographic projection of the Gauss map of the outward pointing normal. As Σ_+ has a catenoidal end, η and G both extend meromorphically to M with η having a simple pole at p_0 and G a simple zero. Moreover, as Σ_+ meets $\{x_3 = 0\}$ at 120° , $|G| = \gamma_0 = \frac{\sqrt{3}}{3} > 0$ on ∂M . As in the proof of Proposition 3.1, the constant contact angle implies that

the flux over any closed loop in Σ_+ is vertical. Hence, by [LR91], the Weierstrass data $(M \setminus \{p_0\}, \eta, \gamma_0^{-1}G)$ parameterizes a new (possibly immersed) minimal surface with boundary Υ_+ and this surface also has a regular end asymptotic to a vertical catenoid. Moreover, $\partial\Upsilon_+ \subset \{x_3 = 0\}$ and, as the boundary of Υ_+ is parameterized by ∂M , the choice of Weierstrass data ensures Υ_+ meets $\{x_3 = 0\}$ orthogonally. It follows that the set $\Upsilon = \Upsilon_+ \cup R_0(\Upsilon_+)$ given by taking the union of Υ_+ with its reflection across $\{x_3 = 0\}$ gives a connected smooth minimal (possibly immersed) surface with two regular ends. As [Sch83] applies to immersed minimal surfaces, it follows that Υ is a vertical catenoid. As the Lopez-Ros deformation of a vertical catenoid is just a reparameterization of the original catenoid, it follows that Σ_+ is also a subset of a vertical catenoid. From this one immediately concludes that Σ is a Y -catenoid. \square

5. FURTHER REMARKS AND OPEN QUESTIONS

We conclude with some further remarks and questions about minimal Plateau surfaces in slabs. First of all, we observe that having appropriate boundary regularity seems to be essential to the proof of Theorem 1.2. This is something we explore more thoroughly in [BM20] and motivates the following question:

Question 5.1. *Is it possible to find a circle Γ in $\{x_3 = 0\}$ so that if $\Gamma_{\pm} = \Gamma \pm \mathbf{e}_3 \subset \{x_3 = \pm 1\}$, then there is a minimal Plateau surface Σ in $\mathbb{R}^3 \setminus \Gamma_- \cup \Gamma_+$ which does not possess rotational symmetry?*

A plausible candidate surface would be to desingularize the union of an appropriately scaled pieces of Cat and Cat_Y . Less clear is whether the orientability condition is necessary. This motivates the following questions:

Question 5.2. *Fix two curves Γ_0 and Γ_1 in parallel planes – not necessarily convex. Is there a minimal Plateau surface Σ with $\partial\Sigma = \Gamma_0 \cup \Gamma_1$ so that Σ does not have an associated cell structure? Even if such examples exist for general choices of curves, does the conclusion of Theorem 1.2 still hold? I.e., is the cell condition unnecessary in the convex or circular case?*

Theorem 1.2 applies to “unstable” minimal Plateau surfaces as well as to the physical “stable” ones. It would be interesting to rigorously produce examples of these sorts examples for large classes of curves. One approach would be to develop a min-max theory in this setting.

Question 5.3. *Can one produce unstable singular minimal Plateau surfaces that span pairs of convex curves?*

Alternatively, one could hope to develop a degree theory analogous to the theory developed by Meeks and White to study the space of minimal annuli spanning a pair of convex curves [MIW93, MIW91]. In particular, they show that generic pairs of convex curves are spanned by either no minimal annulus or exactly two, one stable and the other unstable. One may ask to what extent this generalizes to minimal Plateau surfaces that are topologically Cat_Y – i.e. an annulus with a disk glued in.

Question 5.4. *Can one characterize the space of Plateau minimal surfaces that are topologically Cat_Y surfaces and span pairs of convex curves? For generic pairs are there exactly two such surfaces, one stable and one unstable?*

The Convex Curves conjecture of Meeks [MI78] states that the only connected minimal surfaces spanning two convex curves in parallel planes are topological annuli. One may ask an analogous question in the Plateau setting.

Question 5.5. *Must a singular minimal Plateau surface spanning a pair of convex curves be topologically Cat_Y ? What if the curves are coaxial circles?*

Theorem 1.2 shows the answer is yes when the curves are vertical translations of one another provided the surface is cellular – in the smooth setting this is a result of Ros [Ros96] and Schoen [Sch83].

Finally, catenoids possess an interesting variational property. Namely in [BB14] the authors show that an appropriate piece of the catenoid has the least area among minimal annuli whose boundaries lie in two fixed parallel planes. This was generalized in [CD16] who increased the class of competitors to a larger class of (smooth) minimal surfaces of different topological type. One may ask the same question in the class of singular minimal Plateau surfaces.

Question 5.6. *Among minimal Plateau surfaces spanning two fixed parallel planes what is the least area singular surface? Is it an appropriate piece of Cat_Y ?*

Minimal Plateau surfaces with singularities are expected to arise as area minimizers when formulating Plateau’s problem for two parallel circles via the homotopic spanning condition introduced by Harrison and Pugh [HP16, DLGM17]; see, e.g., [KMS19, Figure 1-2(b)].

REFERENCES

- [Ale62] A. D. Alexandrov. A characteristic property of spheres. *Ann. Mat. Pura Appl. (4)*, 58:303–315, 1962.
- [All72] W. K. Allard. On the first variation of a varifold. *Ann. Math.*, 95:417–491, 1972.
- [BB14] J. Bernstein and C. Breiner. A variational characterization of the catenoid. *Calc. Var. Partial Differential Equations*, 49(1-2):215–232, 2014.
- [BM20] J. Bernstein and F. Maggi. 2020.
- [CD16] J. Choe and B. Daniel. On the area of minimal surfaces in a slab. *Int. Math. Res. Not. IMRN*, (23):7201–7211, 2016.
- [CHHW19] K. Choi, R. Haslhofer, O. Hershkovits, and B. White. Ancient asymptotically cylindrical flows and applications. 2019. arXiv:1910.00639.
- [Dav14] G. David. Should we solve Plateau’s problem again? In *Advances in analysis: the legacy of Elias M. Stein*, volume 50 of *Princeton Math. Ser.*, pages 108–145. Princeton Univ. Press, Princeton, NJ, 2014.
- [DLDRG19] C. De Lellis, A. De Rosa, and F. Ghiraldin. A direct approach to the anisotropic Plateau problem. *Adv. Calc. Var.*, 12(2):211–223, 2019.
- [DLGM17] C. De Lellis, F. Ghiraldin, and F. Maggi. A direct approach to Plateau’s problem. *J. Eur. Math. Soc. (JEMS)*, 19(8):2219–2240, 2017.
- [DM19] M. G. Delgadino and F. Maggi. Alexandrov’s theorem revisited. *Anal. PDE*, 12(6):1613–1642, 2019.
- [EWW02] T. Ekholm, B. White, and D. Wienholtz. Embeddedness of minimal surfaces with total boundary curvature at most 4π . *Ann. of Math. (2)*, 155(1):209–234, 2002.
- [Fan16] Y. Fang. Existence of minimizers for the Reifenberg Plateau problem. *Ann. Sc. Norm. Super. Pisa Cl. Sci. (5)*, 16(3):817–844, 2016.
- [FCS80] D. Fischer-Colbrie and R. Schoen. The structure of complete stable minimal surfaces in 3-manifolds of nonnegative scalar curvature. *Commun. Pure Appl. Math.*, 33(2):199–211, 1980.
- [FK18] Y. Fang and S. Kolasiński. Existence of solutions to a general geometric elliptic variational problem. *Calc. Var. Partial Differential Equations*, 57(3):Art. 91, 71, 2018.

- [HHW20] R. Haslhofer, O. Hershkovits, and B. White. Moving plane method for varifolds and applications. 2020.
- [HMI90] D. Hoffman and W. H. Meeks III. The strong halfspace theorem for minimal surfaces. *Invent. Math.*, 101(2):373–377, 1990.
- [HP16] J. Harrison and H. Pugh. Existence and soap film regularity of solutions to Plateau’s problem. *Adv. Calc. Var.*, 9(4):357–394, 2016.
- [HP17] J. Harrison and H. Pugh. General methods of elliptic minimization. *Calc. Var. Partial Differential Equations*, 56(4):Art. 123, 25, 2017.
- [KMS19] D. King, F. Maggi, and S. Stuvard. Plateau’s problem as a singular limit of capillarity problems. 2019.
- [KNS78] D. Kinderlehrer, L. Nirenberg, and J. Spruck. Regularity in elliptic free boundary problems. *J. Analyse Math.*, 34:86–119 (1979), 1978.
- [LM96] G. Lawlor and F. Morgan. Curvy slicing proves that triple junctions locally minimize area. *J. Differential Geom.*, 44(3):514–528, 1996.
- [LR91] F. J. López and A. Ros. On embedded complete minimal surfaces of genus zero. *J. Differential Geom.*, 33(1):293–300, 1991.
- [MI78] W. H. Meeks III. *Lectures on Plateau’s problem*. 1978. IMPA, Rio, Brazil.
- [MIW91] W. H. Meeks III and B. White. Minimal surfaces bounded by convex curves in parallel planes. *Comment. Math. Helv.*, 66(2):263–278, 1991.
- [MIW93] W. H. Meeks III and B. White. The space of minimal annuli bounded by an extremal pair of planar curves. *Comm. Anal. Geom.*, 1(3-4):415–437, 1993.
- [Pla73] J. Plateau. *Statique expérimentale et théorique des liquides soumis aux seules forces moléculaires*. 1873.
- [PR93] J. Pérez and A. Ros. Some uniqueness and nonexistence theorems for embedded minimal surfaces. *Math. Ann.*, 295(1):513–525, 1993.
- [Pyo12] J. Pyo. Remarks on minimal annuli in a slab. *Arch. Math. (Basel)*, 98(2):193–198, 2012.
- [Rei60] E. R. Reifenberg. Solution of the Plateau problem for m -dimensional surfaces of varying topological type. *Acta Math.*, 104:1–92, 1960.
- [Rei64a] E. R. Reifenberg. An epiperimetric inequality related to the analyticity of minimal surfaces. *Ann. of Math.*, 80(2):1–14, 1964.
- [Rei64b] E. R. Reifenberg. On the analyticity of minimal surfaces. *Ann. of Math.*, 80(2):15–21, 1964.
- [Ros96] A. Ros. Embedded minimal surfaces: forces, topology and symmetries. *Calc. Var. Partial Differential Equations*, 496:469–496, 1996.
- [Ros19] L. Rosales. A hopf-type boundary point lemma for pairs of solutions to quasilinear equations. *Can. Math. Bull.*, 62(3):607–621, 2019.
- [Sch83] R. M. Schoen. Uniqueness, symmetry, and embeddedness of minimal surfaces. *J. Differential Geom.*, 18(4):791–809 (1984), 1983.
- [Sim93] L. Simon. Cylindrical tangent cones and the singular set of minimal submanifolds. *J. Differential Geom.*, 38(3):585–652, 1993.
- [ST19] S. Stuvard and Y. Tonegawa. An existence theorem for brakke flow with fixed boundary conditions, 2019.
- [Tay73] J. E. Taylor. Regularity of the singular sets of two-dimensional area-minimizing flat chains modulo 3 in R^3 . *Invent. Math.*, 22:119–159, 1973.
- [Tay76] J. E. Taylor. The structure of singularities in soap-bubble-like and soap-film-like minimal surfaces. *Ann. of Math. (2)*, 103(3):489–539, 1976.

DEPARTMENT OF MATHEMATICS, JOHNS HOPKINS UNIVERSITY, 3400 N. CHARLES STREET, BALTIMORE, MD 21218

E-mail address: bernstein@math.jhu.edu

DEPARTMENT OF MATHEMATICS, THE UNIVERSITY OF TEXAS AT AUSTIN, 2515 SPEEDWAY, STOP C1200, AUSTIN TX 78712-1202, USA

E-mail address: maggi@math.utexas.edu