

# RIGIDITY FOR PERIMETER INEQUALITIES UNDER SYMMETRIZATION: STATE OF THE ART AND OPEN PROBLEMS

F. CAGNETTI

ABSTRACT. We review some classical results in symmetrization theory, some recent progress in understanding rigidity, and indicate some open problems.

## 1. INTRODUCTION

The aim of this paper is to give an accessible review to recent results on rigidity for perimeter inequalities in symmetrization theory. We start with a brief premise. The first goal of symmetrization theory is establishing the *monotonicity* of the total energy of a physical system under some geometric procedure, which replaces a generic state of the system with a symmetric one. In this way one shows the existence of global energy minimizers enjoying some natural symmetry properties, and that can therefore be (more or less) explicitly characterized. The *rigidity problem* amounts to understanding whether this symmetrization procedure is *strictly monotone* when applied to initial states that are not symmetric. Another important problem is the study of *stability*, which consists in quantitatively controlling the degree of asymmetry of such initial states in terms of the energy they lose after symmetrization. In this paper we will only focus on the study of rigidity problems. We start by mentioning an important example, related to the isoperimetric inequality (see (1.2) below). The celebrated proof of this inequality given by Ennio De Giorgi (see [19], and [20] for an English translation) relies on the solution of a rigidity problem for Steiner's inequality (see (SI) below). More precisely, a crucial step in De Giorgi's proof consists in showing that convex extremals of Steiner's inequality are symmetric.

In this paper we discuss the most recent results on rigidity for Steiner's inequality and for its Gaussian analogue, Ehrhard's inequality (see (EI) below), and we conclude by stating some open problems. Let us also mention that the study of rigidity for Steiner's inequality in the anisotropic setting, and for the perimeter inequality under spherical symmetrization, are addressed in the forthcoming papers [12] and [30], respectively.

The reader will note that we will devote most of our attention to the study of rigidity for Steiner's inequality. This is because the characterization for the rigidity of Ehrhard's inequality can be stated in a very simple way (see Theorem 4.3), despite the very delicate proof (for which we direct the reader to [11, Theorem 1.3]). In addition, the study of rigidity for Steiner's inequality is rich enough to highlight various key ideas.

**1.1. Steiner's symmetrization.** For  $n \in \mathbb{N}$  and  $1 \leq k \leq n$ , we will denote by  $\mathcal{H}^k$  the  $k$ -dimensional Hausdorff measure. Then, the perimeter of a measurable set  $E \subset \mathbb{R}^n$  can be defined as

$$P(E) := \mathcal{H}^{n-1}(\partial^e E) \in [0, \infty].$$

We recall that the *essential boundary*  $\partial^e E$  of  $E$  is defined as

$$\partial^e E = \mathbb{R}^n \setminus \left( E^{(0)} \cup E^{(1)} \right), \quad (1.1)$$

where, given  $t \in [0, 1]$ ,  $E^{(t)}$  denotes the set of points of ( $n$ -dimensional) density  $t$  of  $E$ ,

$$E^{(t)} = \left\{ x \in \mathbb{R}^n : \lim_{r \rightarrow 0^+} \frac{\mathcal{H}^n(E \cap B(x, r))}{\omega_n r^n} = t \right\},$$

and  $\omega_n$  is the volume of the Euclidean unit ball of  $\mathbb{R}^n$  (see Section 2 for more details). When  $E$  is an open set with Lipschitz boundary,  $\partial^e E$  coincides with the topological boundary  $\partial E$ , and thus  $P(E)$  extends to a general setting the notion of “surface measure” of the boundary. The *Euclidean isoperimetric inequality* can then be written as

$$P(E) \geq P(B_r) \quad \text{for every measurable set } E \subset \mathbb{R}^n, \quad (1.2)$$

where  $r > 0$  is such that  $\mathcal{H}^n(B_r) = \mathcal{H}^n(E)$ . In addition, equality in (1.2) holds if and only if  $E$  is ( $\mathcal{H}^n$ -equivalent to a) ball. As already mentioned, a fundamental tool used in De Giorgi’s proof of (1.2) is the Steiner symmetrization for sets, which is defined as follows. For every point  $x \in \mathbb{R}^n$  we write  $x = (x', y)$ , with  $x' = (x_1, \dots, x_{n-1}) \in \mathbb{R}^{n-1}$  and  $y \in \mathbb{R}$ . For any  $E \subset \mathbb{R}^n$ , we define the “vertical section” of  $E$  at  $x' \in \mathbb{R}^{n-1}$  as

$$E_{x'} := \{y \in \mathbb{R} : (x', y) \in E\}. \quad (1.3)$$

Then, the *Steiner symmetral* of  $E$  with respect to the hyperplane  $\{y = 0\}$  is the set  $E^s \subset \mathbb{R}^n$  given by

$$E^s := \left\{ (x', y) \in \mathbb{R}^n : |y| < \frac{\mathcal{H}^1(E_{x'})}{2} \right\}.$$

Thus,  $E^s$  is the only set which is symmetric by reflection with respect to  $\{y = 0\}$  and such that, for every  $x' \in \mathbb{R}^{n-1}$ , the vertical section  $E_{x'}^s$  is a segment such that  $\mathcal{H}^1(E_{x'}^s) = \mathcal{H}^1(E_{x'})$ , see Figure 1.1.

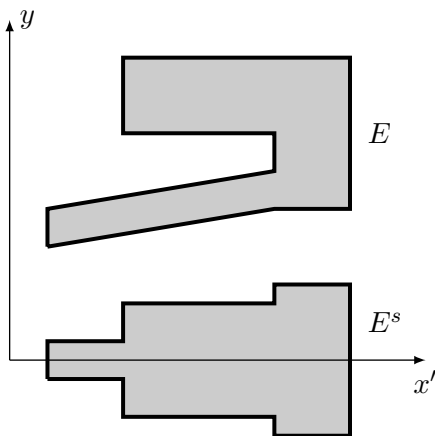

FIGURE 1.1. Steiner symmetrization with respect to  $\{y = 0\}$ .

By Fubini Theorem, one can see that Steiner symmetrization preserves the volume, i.e.  $\mathcal{H}^n(E^s) = \mathcal{H}^n(E)$  for every measurable set  $E$ . More in general, several quantities are not increased under Steiner symmetrization as, for instance:

- the diameter (see [29, Formula (3.9)]);
- the perimeter:  $P(E^s) \leq P(E)$ , see (SI) below;
- the anisotropic perimeter, when the Wulff shape is symmetric with respect to  $\{y = 0\}$  (see for instance, [30]).

Each of the above inequalities leads to a *rigidity problem*, which amounts to answer the following question: If  $E$  is an extremal of the considered inequality, is it true that  $E = E^s$  (up to vertical translations)? We will consider here the important case study of the perimeter functional.

**1.2. Steiner's inequality.** Given a measurable function  $v : \mathbb{R}^{n-1} \rightarrow [0, \infty]$ , we will say that a set  $E \subset \mathbb{R}^n$  is *v-distributed* if

$$v(x') = \mathcal{H}^1(E_{x'}), \quad \text{for } \mathcal{H}^{n-1}\text{-a.e. } x' \in \mathbb{R}^{n-1}. \quad (1.4)$$

Observe now that the Steiner symmetral of a  $v$ -distributed set only depends on the function  $v$ . In order to emphasize this fact, in the following we modify our notation, by setting:

$$F_v := \left\{ (x', y) \in \mathbb{R}^n : |y| < \frac{v(x')}{2} \right\}.$$

In this way, we have  $E^s = F_v$  for every  $v$ -distributed set  $E$ . *Steiner's inequality* then states that the perimeter does not increase under Steiner symmetrisation [29, Theorem 14.4]:

$$P(E) \geq P(F_v), \quad \text{for every } E \subset \mathbb{R}^n \text{ } v\text{-distributed.} \quad (\text{SI})$$

In order to properly formulate the rigidity problem for (SI) we first need to address the regularity properties of the function  $v$  defined in (1.4), when  $E$  is a set of finite perimeter. These are made precise by the following lemma, see [15, Lemma 3.1].

**Lemma 1.1** (Chlebík, Cianchi, and Fusco). *Let  $E$  be a  $v$ -distributed set of finite perimeter in  $\mathbb{R}^n$ , for some measurable function  $v : \mathbb{R}^{n-1} \rightarrow [0, \infty]$ . Then, one and only one of the following two possibilities is satisfied:*

- (a)  $v(x') = \infty$  for  $\mathcal{H}^{n-1}$ -a.e.  $x' \in \mathbb{R}^{n-1}$  and  $E^s$  is  $\mathcal{H}^n$ -equivalent to  $\mathbb{R}^n$ ;
- (b)  $v(x') < \infty$  for  $\mathcal{H}^{n-1}$ -a.e.  $x' \in \mathbb{R}^{n-1}$  and  $\mathcal{H}^n(E) < \infty$ .

**Remark 1.2.** *Case (a) is satisfied, for instance, when  $E$  is the complement of a bounded set with smooth boundary.*

Note now that Steiner's inequality (SI) in particular implies that, if  $E$  is a  $v$ -distributed set of finite perimeter, then  $F_v$  is also a set of finite perimeter. Combining this fact together with Lemma 1.1, it follows that it is not restrictive to assume that both the volume and the perimeter of  $F_v$  are finite. Next lemma explains when this happens, in terms of the function  $v$  (see [10, Proposition 3.2]).

**Lemma 1.3.** *Let  $v : \mathbb{R}^{n-1} \rightarrow [0, \infty]$  be measurable. Then, we have  $\mathcal{H}^n(F_v) < \infty$  and  $P(F_v) < \infty$  if and only if*

$$v \in BV(\mathbb{R}^{n-1}) \quad \text{and} \quad \mathcal{H}^{n-1}(\{v > 0\}) < \infty, \quad (1.5)$$

where  $BV(\mathbb{R}^{n-1})$  denotes the space of functions of bounded variation in  $\mathbb{R}^{n-1}$ , see Section 2.

Given  $v$  as in (1.5), we denote the class of those sets whose perimeter is *preserved* under Steiner symmetrization by

$$\mathcal{M}(v) := \{E \subset \mathbb{R}^n : P(E) = P(F_v)\}.$$

In this context, we say that rigidity is satisfied if the only elements of  $\mathcal{M}(v)$  are the trivial equality cases of (SI), that is, if  $\mathcal{M}(v) = \{t e_n + F_v, t \in \mathbb{R}\}$  (here we denote by  $e_1, \dots, e_n$  the canonical basis in  $\mathbb{R}^n$ ). More precisely, since we do not distinguish between  $\mathcal{H}^n$ -equivalent sets, we will say that *rigidity holds true* for Steiner's inequality if

$$\mathcal{M}(v) = \left\{ E \in \mathbb{R}^n : \mathcal{H}^n(E \Delta (t e_n + F_v)) = 0 \text{ for some } t \in \mathbb{R} \right\}, \quad (\text{SR})$$

where  $\Delta$  denotes the symmetric difference of sets. By the translational invariance of the perimeter, the inclusion  $\supset$  in (SR) is always satisfied, but the opposite inclusion may fail. In [19], De Giorgi showed that (SR) holds true when  $F_v$  is *convex*, and used this fact to prove the isoperimetric inequality. When  $F_v$  is not convex, one can find simple examples in which (SR) fails. In Figure 1.2, for instance, rigidity fails because the (projection of the) set  $F_v$  is disconnected. In Figure 1.3 instead, the fact that  $\partial^e F_v$  contains “flat vertical

parts” allows to violate (SR). When trying to study (SR) in full generality the situation can become very complicated, and will discuss this in detail in Section 3.

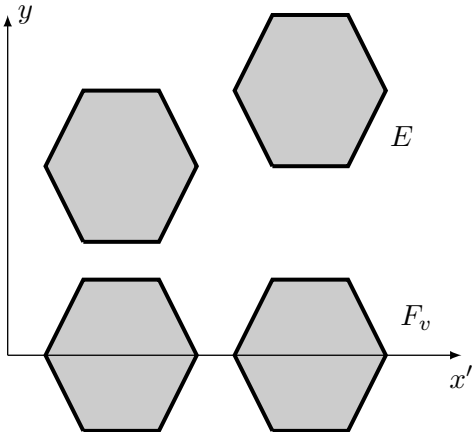

FIGURE 1.2.  $F_v$  is not connected: (SR) fails.

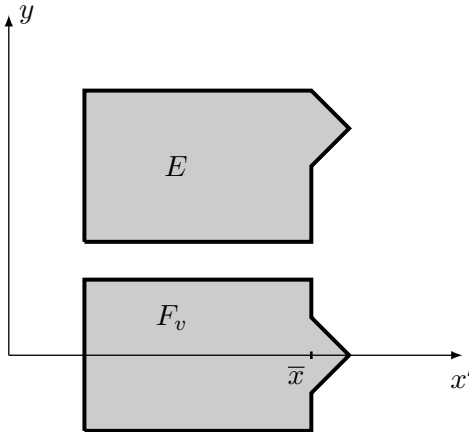

FIGURE 1.3. A connected set  $F_v$  for which (SR) fails.

**1.3. Gaussian perimeter and the Gaussian isoperimetric problem.** Another important rigidity problem arises when considering the Gaussian analogous of Steiner symmetrization. In order to describe the problem we first need some notation. We denote the Gaussian volume of a Lebesgue measurable set  $E \subset \mathbb{R}^n$  by

$$\gamma_n(E) := \frac{1}{(2\pi)^{n/2}} \int_E e^{-|x|^2/2} dx.$$

Moreover, whenever  $1 \leq k \leq n$ , the  $k$ -dimensional Gaussian-Hausdorff measure of a Borel set  $S \subset \mathbb{R}^n$  is given by

$$\mathcal{H}_\gamma^k(S) := \frac{1}{(2\pi)^{k/2}} \int_S e^{-|x|^2/2} d\mathcal{H}^k(x).$$

The Gaussian perimeter of a measurable set  $E$  is then defined as

$$P_\gamma(E) := \mathcal{H}_\gamma^{n-1}(\partial^e E) = \frac{1}{(2\pi)^{(n-1)/2}} \int_{\partial^e E} e^{-|x|^2/2} d\mathcal{H}^{n-1}(x), \quad (1.6)$$

where  $\partial^e E$  is given by (1.1). In the Gaussian setting an important role is played by half-spaces. If we define the function  $\Phi : \mathbb{R} \cup \{\pm\infty\} \rightarrow [0, 1]$  as

$$\Phi(t) := \frac{1}{\sqrt{2\pi}} \int_t^\infty e^{-s^2/2} ds, \quad t \in \mathbb{R} \cup \{\pm\infty\}, \quad (1.7)$$

then  $\Phi(t)$  is the Gaussian volume of a half-space whose “signed distance” from the origin is  $t$ , that is,  $\Phi(t) = \gamma_n(\{x_1 > t\})$  for every  $t \in \mathbb{R}$ . Let us now set  $\Psi := \Phi^{-1}$  so that, for any  $\lambda \in (0, 1)$ ,  $e^{-\Psi(\lambda)^2/2}$  gives the Gaussian perimeter of a half-space with Gaussian volume  $\lambda$ . The *Gaussian isoperimetric inequality* states that half-spaces are the sets that minimize the Gaussian perimeter at fixed Gaussian volume, that is,

$$P_\gamma(E) \geq e^{-\Psi(\gamma_n(E))^2/2} \quad \text{for every measurable set } E \subset \mathbb{R}^n. \quad (1.8)$$

Equality in (1.8) holds true if and only if (up to rotations keeping the origin fixed)  $E$  is a half-space. Inequality (1.8) was proved by many authors with different techniques [8, 31, 3, 7, 28, 6, 22, 23, 24], while the first characterization of equality cases is due to Carlen and Kerce [14]. After that, a characterization of equality cases, together with a stability result with sharp exponent, has been obtained by Cianchi, Fusco, Maggi and

Pratelli [18], where the authors use a symmetrization technique introduced by Ehrhard [22]. Let us mention that the difficult problem of proving a sharp stability inequality, with a constant which is independent of the dimension, has recently been solved by Barchiesi, Brancolini and Julin [4].

**1.4. Ehrhard's symmetrization.** While studying the Gaussian isoperimetric inequality [22, 23, 24], Ehrhard introduced a symmetrization procedure that is the natural analogous of Steiner's symmetrization in the Gaussian setting. Given a Lebesgue measurable function  $w : \mathbb{R}^{n-1} \rightarrow [0, 1]$ , we say that  $E$  is  $w$ -distributed in the Gaussian space if  $\mathcal{H}_\gamma^1(E_{x'}) = w(x')$  for  $\mathcal{H}^{n-1}$ -a.e.  $x' \in \mathbb{R}^{n-1}$ , where  $E_{x'}$  is defined by (1.3). Moreover, we denote by

$$F_{\gamma,w} := \left\{ (x', y) \in \mathbb{R}^n : y > \Psi(w(x')) \right\} \quad (1.9)$$

the set that is  $w$ -distributed in the Gaussian space and whose vertical sections are positive half-lines in the  $y$ -direction. If  $E$  is a  $w$ -distributed set, then the *Ehrhard symmetrals*  $E_\gamma^s$  of  $E$  is defined as

$$E_\gamma^s := F_{\gamma,w},$$

see Figure 1.4.

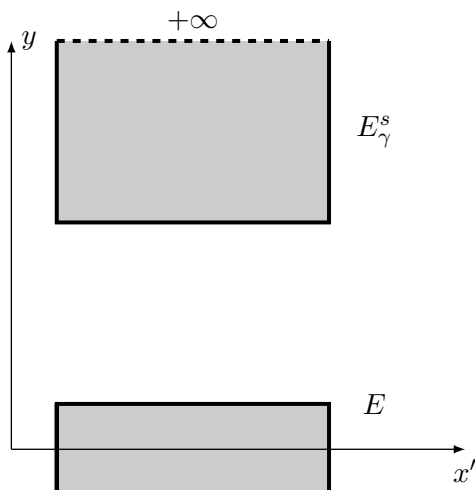

FIGURE 1.4. Ehrhard's symmetrization in the case of a rectangle.

Thanks to Fubini's theorem, one can see that  $\gamma_n(E) = \gamma_n(F_{\gamma,w})$ , that is, Gaussian volume is preserved under Ehrhard's symmetrization. *Ehrhard's inequality* states that Gaussian perimeter does not increase under Ehrhard's symmetrization: if  $P_\gamma(F_{\gamma,w}) < \infty$ , then

$$P_\gamma(E) \geq P_\gamma(F_{\gamma,w}), \quad \text{for every } E \subset \mathbb{R}^n \text{ } w\text{-distributed in the Gauss space.} \quad (\text{EI})$$

A proof of (EI) can be found in [18, Section 4.1]. We now turn to the rigidity problem related to the Ehrhard inequality. For every Lebesgue measurable function  $w : \mathbb{R}^{n-1} \rightarrow [0, 1]$  with  $P_\gamma(F_{\gamma,w}) < \infty$  we set

$$\mathcal{M}_\gamma(w) := \left\{ E \subset \mathbb{R}^n : E \text{ is } w\text{-distributed in the Gauss space and } P_\gamma(E) = P_\gamma(F_{\gamma,w}) \right\}.$$

Denoting by  $q : \mathbb{R}^n \rightarrow \mathbb{R}^n$  the reflection with respect to  $\{y = 0\}$ , that is

$$q(x) = (x', -y), \quad x = (x', y) \in \mathbb{R}^n,$$

we will say that *rigidity holds true for Ehrhard's inequality* when

$$E \in \mathcal{M}_\gamma(w) \iff \text{either } \mathcal{H}^n(E \Delta F_{\gamma,w}) = 0 \text{ or } \mathcal{H}^n(E \Delta q(F_{\gamma,w})) = 0. \quad (\text{ER})$$

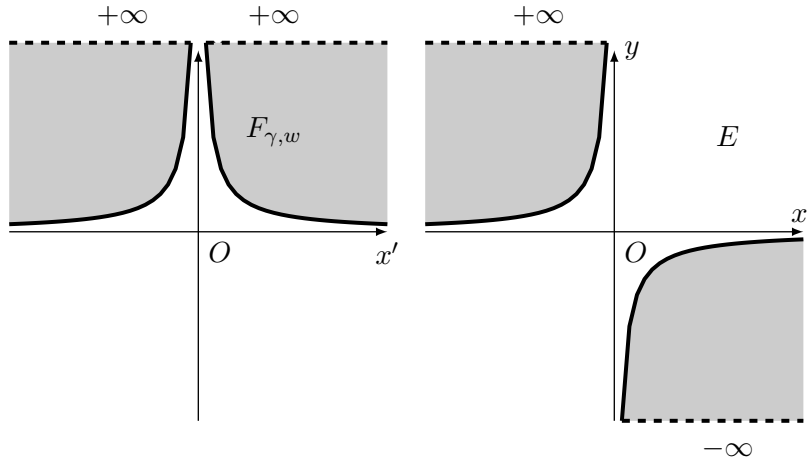

FIGURE 1.5. Rigidity fails: this is due to the fact that  $w(O) = 0$ .

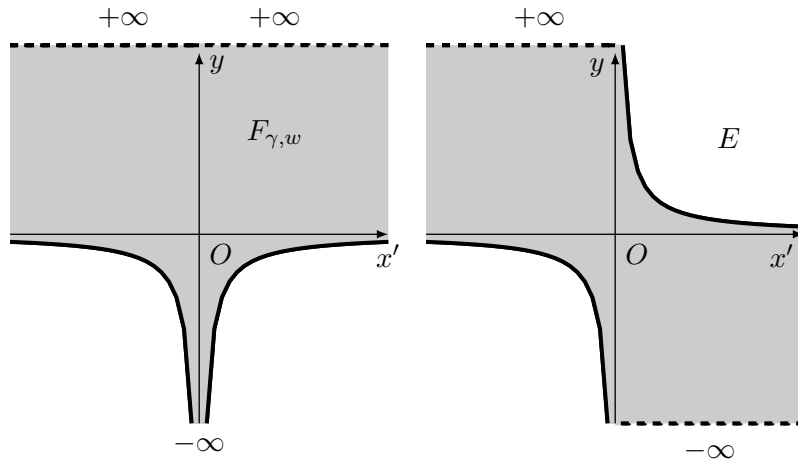

FIGURE 1.6. Rigidity fails: this is due to the fact that  $w(O) = 1$ .

Simple examples show that (ER) may fail if we allow  $w$  to take the values 0 or 1, see Figure 1.5 and Figure 1.6. However, Figure 1.7 seems to suggest that the situation is a bit more complicated, since one needs to take into account for possible “discontinuities” of  $w$ . We will give in Section 4 the complete characterization of (ER) proved in [11], based on the notion of *essential connectedness*.

**1.5. Plan of the paper.** In Section 2 we introduce some notions from geometric measure theory, and give the definition of essential connectedness. The study of the rigidity for Ehrhard’s and Steiner’s inequality are the subject of Section 4 and Section 3, respectively. Finally, in Section 5 we discuss some open problems.

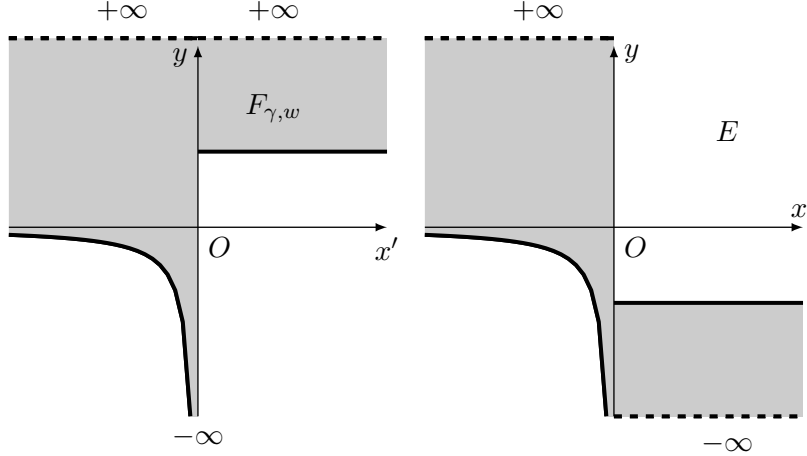

FIGURE 1.7. Rigidity fails: this is due to the fact that  $w^\vee(O) = 1$ .

## 2. NOTIONS FROM GEOMETRIC MEASURE THEORY AND ESSENTIAL CONNECTEDNESS

In this section we introduce some tools from Geometric Measure Theory. The interested reader can find more details in the monographs [25, 2, 29] and in the papers [10, 11].

**2.1. General notation in  $\mathbb{R}^n$ .** We denote by  $B(x, r)$  and  $\bar{B}(x, r)$  the open and closed Euclidean balls of radius  $r > 0$  and center  $x \in \mathbb{R}^n$ . For  $x \in \mathbb{R}^n$  and  $\nu \in \mathbb{S}^{n-1}$ , we will denote by  $H_{x,\nu}^+$  and  $H_{x,\nu}^-$  the closed half-spaces whose boundaries are orthogonal to  $\nu$ :

$$\begin{aligned} H_{x,\nu}^+ &:= \left\{ y \in \mathbb{R}^n : (y - x) \cdot \nu \geq 0 \right\}, \\ H_{x,\nu}^- &:= \left\{ y \in \mathbb{R}^n : (y - x) \cdot \nu \leq 0 \right\}. \end{aligned} \quad (2.1)$$

If  $\{E_h\}_{h \in \mathbb{N}}$  is a sequence of Lebesgue measurable sets in  $\mathbb{R}^n$  and  $E \subset \mathbb{R}^n$  is also measurable, we say that  $\{E_h\}_{h \in \mathbb{N}}$  locally converges to  $E$ , and write

$$E_h \xrightarrow{\text{loc}} E, \quad \text{as } h \rightarrow \infty,$$

provided  $\mathcal{H}^n((E_h \Delta E) \cap K) \rightarrow 0$  as  $h \rightarrow \infty$  for every compact set  $K \subset \mathbb{R}^n$ . Accordingly, we say that  $\{E_h\}_{h \in \mathbb{N}}$  converges to  $E$  as  $h \rightarrow \infty$ , and write  $E_h \rightarrow E$ , if  $\mathcal{H}^n(E_h \Delta E) \rightarrow 0$  as  $h \rightarrow \infty$ . In the following, we will denote by  $\chi_E$  the characteristic function of a measurable set  $E \subset \mathbb{R}^n$ .

**2.2. Density points.** Let  $E \subset \mathbb{R}^n$  be a Lebesgue set and let  $x \in \mathbb{R}^n$ . We define the upper and lower  $n$ -dimensional densities of  $E$  at  $x$  as

$$\theta^*(E, x) := \limsup_{r \rightarrow 0^+} \frac{\mathcal{H}^n(E \cap \bar{B}(x, r))}{\omega_n r^n}, \quad \theta_*(E, x) := \liminf_{r \rightarrow 0^+} \frac{\mathcal{H}^n(E \cap \bar{B}(x, r))}{\omega_n r^n},$$

respectively. Note that  $\theta^*(E, \cdot)$  and  $\theta_*(E, \cdot)$  are Borel functions on  $\mathbb{R}^n$  that agree a.e. on  $\mathbb{R}^n$ . Thus, the  $n$ -dimensional density of  $E$  at  $x$

$$\theta(E, x) := \lim_{r \rightarrow 0^+} \frac{\mathcal{H}^n(E \cap \bar{B}(x, r))}{\omega_n r^n} = \lim_{r \rightarrow 0^+} \frac{\mathcal{H}^n(E \cap B(x, r))}{\omega_n r^n},$$

is defined for  $\mathcal{H}^n$ -a.e.  $x \in \mathbb{R}^n$ , and  $\theta(E, \cdot)$  is a Borel function on  $\mathbb{R}^n$ . Setting  $E^{(t)} := \{x \in \mathbb{R}^n : \theta(E, x) = t\}$  for every  $t \in [0, 1]$ , by the Lebesgue differentiation theorem we have that  $\{E^{(0)}, E^{(1)}\}$  is a partition of  $\mathbb{R}^n$  up to a  $\mathcal{H}^n$ -negligible set. The set  $\partial^e E := \mathbb{R}^n \setminus (E^{(0)} \cup E^{(1)})$  is called the *essential boundary* of  $E$ . Note that, if  $E$  is a measurable set, we only have  $\mathcal{H}^n(\partial^e E) = 0$ , and in general  $\partial^e E$  may not be “ $(n - 1)$ -dimensional”.

Let  $f : \mathbb{R}^n \rightarrow \mathbb{R} \cup \{\pm\infty\}$  be a Lebesgue measurable function. We define the *approximate upper limit*  $f^\vee(x)$  and the *approximate lower limit*  $f^\wedge(x)$  of  $f$  at  $x \in \mathbb{R}^n$  as

$$f^\vee(x) = \inf \left\{ t \in \mathbb{R} : x \in \{f > t\}^{(0)} \right\}, \quad (2.2)$$

$$f^\wedge(x) = \sup \left\{ t \in \mathbb{R} : x \in \{f < t\}^{(0)} \right\}. \quad (2.3)$$

Note that  $f^\vee$  and  $f^\wedge$  are Borel functions defined at *every* point of  $\mathbb{R}^n$ , with values in  $\mathbb{R} \cup \{\pm\infty\}$ . Moreover, if  $f_1 = f_2$   $\mathcal{H}^n$ -a.e. on  $\mathbb{R}^n$ , then  $f_1^\vee = f_2^\vee$  and  $f_1^\wedge = f_2^\wedge$  *everywhere* on  $\mathbb{R}^n$ . Therefore, the *approximate discontinuity* set of  $f$ ,  $S_f = \{f^\wedge < f^\vee\}$ , satisfies  $\mathcal{H}^n(S_f) = 0$ . Note that, even if  $f^\wedge$  and  $f^\vee$  may take infinite values on  $S_f$ , the difference  $f^\vee(x) - f^\wedge(x)$  is well defined in  $\mathbb{R} \cup \{\pm\infty\}$  for every  $x \in S_f$ . We then define the *approximate jump* of  $f$  as the Borel function  $[f] : \mathbb{R}^n \rightarrow [0, \infty]$  given by

$$[f](x) := \begin{cases} f^\vee(x) - f^\wedge(x), & \text{if } x \in S_f, \\ 0, & \text{if } x \in \mathbb{R}^n \setminus S_f, \end{cases}$$

so that  $S_f = \{[f] > 0\}$ . Let  $A \subset \mathbb{R}^n$  be a Lebesgue measurable set. We say that  $t \in \mathbb{R} \cup \{\pm\infty\}$  is the *approximate limit* of  $f$  at  $x$  with respect to  $A$ , and write  $t = \text{ap lim}(f, A, x)$ , if

$$\begin{aligned} \theta(\{|f - t| > \varepsilon\} \cap A; x) &= 0, & \forall \varepsilon > 0, & \quad (t \in \mathbb{R}), \\ \theta(\{f < M\} \cap A; x) &= 0, & \forall M > 0, & \quad (t = +\infty), \\ \theta(\{f > -M\} \cap A; x) &= 0, & \forall M > 0, & \quad (t = -\infty). \end{aligned}$$

We say that  $x \in S_f$  is a *jump point* of  $f$  if there exists  $\nu \in \mathbb{S}^{n-1}$  such that

$$f^\vee(x) = \text{ap lim}(f, H_{x,\nu}^+, x), \quad f^\wedge(x) = \text{ap lim}(f, H_{x,\nu}^-, x).$$

If this is the case, we say that  $\nu_f(x) := \nu$  is the *approximate jump direction* of  $f$  at  $x$ . If we denote by  $J_f$  the set of approximate jump points of  $f$ , we have that  $J_f \subset S_f$  and  $\nu_f : J_f \rightarrow \mathbb{S}^{n-1}$  is a Borel function. Finally, we say that  $f$  is *approximately differentiable* at  $x \in S_f^c = \mathbb{R}^n \setminus S_f$  provided  $f^\wedge(x) = f^\vee(x) \in \mathbb{R}$  and there exists  $\xi \in \mathbb{R}^n$  such that

$$\text{ap lim}(g_\xi, \mathbb{R}^n, x) = 0,$$

where  $g_\xi(y) := (f(y) - \tilde{f}(x) - \xi \cdot (y - x)) / |y - x|$  for  $y \in \mathbb{R}^n \setminus \{x\}$ , and  $\tilde{f}(x) := f^\wedge(x) = f^\vee(x)$ . If this is the case, then  $\xi$  is uniquely determined, we set  $\nabla f(x) := \xi$ , and call  $\nabla f(x)$  the *approximate differential* of  $f$  at  $x$ .

**2.3. Rectifiable sets.** Let  $1 \leq k \leq n$ ,  $k \in \mathbb{N}$ . Here and in the following, when  $A, B \subset \mathbb{R}^n$  are Borel sets, we say that  $A \subset_{\mathcal{H}^k} B$  if  $\mathcal{H}^k(B \setminus A) = 0$  and  $A =_{\mathcal{H}^k} B$  if  $\mathcal{H}^k(A \Delta B) = 0$ . A Borel set  $M \subset \mathbb{R}^n$  is said *countably  $\mathcal{H}^k$ -rectifiable* if there exist Lipschitz functions  $f_h : \mathbb{R}^k \rightarrow \mathbb{R}^n$  ( $h \in \mathbb{N}$ ) such that  $M \subset_{\mathcal{H}^k} \bigcup_{h \in \mathbb{N}} f_h(\mathbb{R}^k)$ . We further say that  $M$  is *locally  $\mathcal{H}^k$ -rectifiable* if  $\mathcal{H}^k(M \cap K) < \infty$  for every compact set  $K \subset \mathbb{R}^n$ , or, equivalently, if  $\mathcal{H}^k \llcorner M$  is a Radon measure on  $\mathbb{R}^n$ . Let  $M$  be a locally  $\mathcal{H}^k$ -rectifiable set in  $\mathbb{R}^n$ , let  $x \in \mathbb{R}^n$ , and let  $L$  be a  $k$ -dimensional subspace of  $\mathbb{R}^n$ . We say that  $L$  is the *approximate tangent plane* of  $M$  at  $x$  if  $\mathcal{H}^k \llcorner (M - x) / r \rightharpoonup \mathcal{H}^k \llcorner L$  as  $r \rightarrow 0^+$  weakly-star in the sense of Radon measures. If this is the case, we set  $T_x M := L$ . It turns out that  $T_x M$  exists and is uniquely defined at  $\mathcal{H}^k$ -a.e.  $x \in M$ . Moreover, given two locally  $\mathcal{H}^k$ -rectifiable sets  $M_1$  and  $M_2$  in  $\mathbb{R}^n$ , we have  $T_x M_1 = T_x M_2$  for  $\mathcal{H}^k$ -a.e.  $x \in M_1 \cap M_2$ .

A Lebesgue measurable set  $E \subset \mathbb{R}^n$  is said of *locally finite perimeter* in  $\mathbb{R}^n$  if there exists an  $\mathbb{R}^n$ -valued Radon measure  $\mu_E$ , called the *Gauss–Green measure* of  $E$ , such that

$$\int_E \nabla \varphi(x) dx = \int_{\mathbb{R}^n} \varphi(x) d\mu_E(x), \quad \forall \varphi \in C_c^1(\mathbb{R}^n).$$



The relative perimeter of  $E$  in  $A \subset \mathbb{R}^n$  is then defined by setting  $P(E; A) := |\mu_E|(A)$  for any Borel set  $A \subset \mathbb{R}^n$ , while  $P(E) := P(E; \mathbb{R}^n)$  is the perimeter of  $E$ . The *reduced boundary* of  $E$  is the set  $\partial^* E$  of those  $x \in \mathbb{R}^n$  such that

$$\nu^E(x) = \lim_{r \rightarrow 0^+} \frac{\mu_E(B(x, r))}{|\mu_E|(B(x, r))} \quad \text{exists and belongs to } \mathbb{S}^{n-1}.$$

The Borel function  $\nu^E : \partial^* E \rightarrow \mathbb{S}^{n-1}$  is called the *measure-theoretic outer unit normal* to  $E$ . When  $x \in \partial^* E$ , we will use the decomposition  $\nu^E(x) = (\nu_{x'}^E(x), \nu_y^E(x))$ , with  $\nu_{x'}^E(x) = (\nu_1^E(x), \dots, \nu_{n-1}^E(x)) \in \mathbb{R}^{n-1}$ , and  $\nu_y^E(x) \in \mathbb{R}$ . One can show that  $\partial^* E$  is a locally  $\mathcal{H}^{n-1}$ -rectifiable set in  $\mathbb{R}^n$  [29, Corollary 16.1], with  $\mu_E = \nu^E \mathcal{H}^{n-1} \llcorner \partial^* E$ , and

$$\int_E \nabla \varphi(x) dx = \int_{\partial^* E} \varphi(x) \nu^E(x) d\mathcal{H}^{n-1}(x), \quad \forall \varphi \in C_c^1(\mathbb{R}^n).$$

In particular,  $P(E; A) = \mathcal{H}^{n-1}(A \cap \partial^* E)$  for every Borel set  $A \subset \mathbb{R}^n$ . We say that  $x \in \mathbb{R}^n$  is a *jump point* of  $E$ , if there exists  $\nu \in \mathbb{S}^{n-1}$  such that (here we set  $E_{x,r} := \frac{E-x}{r}$ )

$$E_{x,r} \xrightarrow{\text{loc}} H_{0,\nu}^+, \quad \text{as } r \rightarrow 0^+, \quad (2.4)$$

and we denote by  $\partial^J E$  the set of *jump points* of  $E$ . Notice that we always have  $\partial^J E \subset E^{(1/2)} \subset \partial^e E$ . In fact, if  $E$  is a set of locally finite perimeter and  $x \in \partial^* E$ , then (2.4) holds with  $\nu = -\nu_E(x)$ , so that  $\partial^* E \subset \partial^J E$ . Therefore, if  $E$  is a set of locally finite perimeter we have

$$\partial^* E \subset \partial^J E \subset E^{(1/2)} \subset \partial^e E. \quad (2.5)$$

Moreover, by *Federer's theorem* (see [2, Theorem 3.61] and [29, Theorem 16.2])

$$\mathcal{H}^{n-1}(\partial^e E \setminus \partial^* E) = 0,$$

so that the essential boundary  $\partial^e E$  of  $E$  is locally  $\mathcal{H}^{n-1}$ -rectifiable in  $\mathbb{R}^n$ .

**2.4. Functions of bounded variation.** Given a Lebesgue measurable function  $f : \mathbb{R}^n \rightarrow \mathbb{R}$  and an open set  $\Omega \subset \mathbb{R}^n$  we define the *total variation of  $f$  in  $\Omega$*  as

$$|Df|(\Omega) = \sup \left\{ \int_{\Omega} f(x) \operatorname{div} T(x) dx : T \in C_c^1(\Omega; \mathbb{R}^n), |T| \leq 1 \right\}.$$

We say that  $f$  belongs to the space of functions of bounded variations,  $f \in BV(\Omega)$ , if  $|Df|(\Omega) < \infty$  and  $f \in L^1(\Omega)$ . Moreover, we say that  $f \in BV_{loc}(\Omega)$  if  $f \in BV(\Omega')$  for every open set  $\Omega'$  compactly contained in  $\Omega$ . Therefore, if  $f \in BV_{loc}(\mathbb{R}^n)$  the distributional derivative  $Df$  of  $f$  is an  $\mathbb{R}^n$ -valued Radon measure. In particular,  $E$  is a set of locally finite perimeter if and only if  $\chi_E \in BV_{loc}(\mathbb{R}^n)$ , and in this case  $\mu_E = -D\chi_E$ . Sets of finite perimeter and functions of bounded variation are related by the fact that, if  $f \in BV_{loc}(\mathbb{R}^n)$ , then, for a.e.  $t \in \mathbb{R}$ ,  $\{f > t\}$  is a set of finite perimeter, and the *coarea formula*,

$$\int_{\mathbb{R}} P(\{f > t\}; G) dt = |Df|(G), \quad (2.6)$$

holds (as an identity in  $[0, \infty]$ ) for every Borel set  $G \subset \mathbb{R}^n$ . If  $f \in BV_{loc}(\mathbb{R}^n)$ , then the Radon–Nykodim decomposition of  $Df$  with respect to  $\mathcal{H}^n$  is denoted by  $Df = D^a f + D^s f$ , where  $D^s f$  and  $\mathcal{H}^n$  are mutually singular, and where  $D^a f \ll \mathcal{H}^n$ . The density of  $D^a f$  with respect to  $\mathcal{H}^n$  is by convention denoted as  $\nabla f$ , so that  $\nabla f \in L^1(\Omega; \mathbb{R}^n)$  with  $D^a f = \nabla f d\mathcal{H}^n$ . Moreover, for a.e.  $x \in \mathbb{R}^n$ ,  $\nabla f(x)$  is the approximate differential of  $f$  at  $x$ . If  $f \in BV_{loc}(\mathbb{R}^n)$ , then  $S_f$  is countably  $\mathcal{H}^{n-1}$ -rectifiable, with  $\mathcal{H}^{n-1}(S_f \setminus J_f) = 0$ ,  $[f] \in L_{loc}^1(\mathcal{H}^{n-1} \llcorner J_f)$ , and the  $\mathbb{R}^n$ -valued Radon measure  $D^j f$  defined as

$$D^j f = [f] \nu_f d\mathcal{H}^{n-1} \llcorner J_f,$$

is called the *jump part of  $Df$* . Since  $D^a f$  and  $D^j f$  are mutually singular, by setting  $D^c f = D^s f - D^j f$  we come to the canonical decomposition of  $Df$  into the sum  $D^a f + D^j f + D^c f$ .

The  $\mathbb{R}^n$ -valued Radon measure  $D^c f$  is called the *Cantorian part* of  $Df$ , and it has the property that  $|D^c f|(M) = 0$  for every  $M \subset \mathbb{R}^n$  which is  $\sigma$ -finite with respect to  $\mathcal{H}^{n-1}$ .

**2.5. Generalized functions of bounded variation.** Given a Lebesgue measurable function  $f : \mathbb{R}^n \rightarrow \mathbb{R}$  we say that  $f$  is a function of *generalized bounded variation* on  $\mathbb{R}^n$ ,  $f \in GBV(\mathbb{R}^n)$ , if  $\psi \circ f \in BV_{loc}(\mathbb{R}^n)$  for every  $\psi \in C^1(\mathbb{R})$  with  $\psi' \in C_c^0(\mathbb{R})$ , or, equivalently, if  $\tau_M(f) \in BV_{loc}(\mathbb{R}^n)$  for every  $M > 0$ , where

$$\tau_M(s) := \max\{-M, \min\{M, s\}\}, \quad s \in \mathbb{R} \cup \{\pm\infty\}. \quad (2.7)$$

Notice that, if  $f \in GBV(\mathbb{R}^n)$ , then we do not even ask that  $f \in L^1_{loc}(\mathbb{R}^n)$ , so that the distributional derivative  $Df$  of  $f$  may even fail to be defined. Nevertheless, the structure theory of  $BV$  functions holds for  $GBV$  functions too. Indeed, if  $f \in GBV(\mathbb{R}^n)$ , then (see [2, Theorem 4.34]),  $\{f > t\}$  is a set of finite perimeter for a.e.  $t \in \mathbb{R}$ ,  $f$  is approximately differentiable  $\mathcal{H}^n$ -a.e. on  $\mathbb{R}^n$ ,  $S_f$  is countably  $\mathcal{H}^{n-1}$ -rectifiable and  $\mathcal{H}^{n-1}$ -equivalent to  $J_f$ , and the coarea formula (2.6) takes the form

$$\int_{\mathbb{R}} P(\{f > t\}; G) dt = \int_G |\nabla f| d\mathcal{H}^n + \int_{G \cap S_f} [f] d\mathcal{H}^{n-1} + |D^c f|(G), \quad (2.8)$$

for every Borel set  $G \subset \mathbb{R}^n$ , where  $|D^c f|$  denotes the Borel measure on  $\mathbb{R}^n$  defined as the least upper bound of the Radon measures  $|D^c(\tau_M(f))|$ , and we have

$$|D^c f|(G) = \lim_{M \rightarrow \infty} |D^c(\tau_M(f))|(G) = \sup_{M > 0} |D^c(\tau_M(f))|(G), \quad (2.9)$$

whenever  $G$  is a Borel set in  $\mathbb{R}^n$  (see [2, Definition 4.33]).

**2.6. A measure-theoretic notion of connectedness.** Let  $m \in \mathbb{N}$ . We would like to describe in a rigorous way the situation in which a “full dimensional” set  $G \subset \mathbb{R}^m$  is disconnected by an “ $(m - 1)$ -dimensional” set  $K \subset \mathbb{R}^m$ . Roughly speaking, when  $G$  is an open set and  $K$  is a smooth hypersurface in  $\mathbb{R}^m$ , we have that  $K$  disconnects  $G$  if the following is true: One can find two disjoint non-empty open sets  $G_+$  and  $G_-$  such that  $G = G_+ \cup G_-$  (up to a set of  $\mathcal{H}^m$ -measure zero) and such that the set  $\partial G_+ \cap \partial G_- \cap G$  lies inside  $K$ , see Figure 2.1 and Figure 2.2.

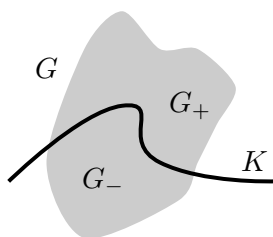

FIGURE 2.1. The set  $K$  disconnects  $G$ .

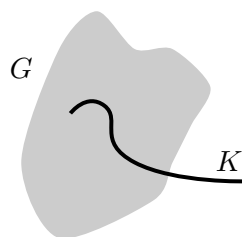

FIGURE 2.2.  $K$  does not disconnect  $G$ .

In the following, given a Borel set  $G \subset \mathbb{R}^m$ , we will say that  $\{G_+, G_-\}$  is a non-trivial Borel partition of  $G$  modulo  $\mathcal{H}^m$  if  $G_+, G_-$  are Borel sets and

$$\mathcal{H}^m(G_+ \cap G_-) = 0, \quad \mathcal{H}^m(G \Delta (G_+ \cup G_-)) = 0, \quad \mathcal{H}^m(G_+) \mathcal{H}^m(G_-) > 0. \quad (2.10)$$

The previous considerations suggest the following definition [11, Section 1.5]. Given two Borel sets  $K$  and  $G$  in  $\mathbb{R}^m$ , we say that  $K$  *essentially disconnects*  $G$  if there exists a non-trivial Borel partition  $\{G_+, G_-\}$  of  $G$  modulo  $\mathcal{H}^m$  with

$$\mathcal{H}^{m-1}\left(\left(G^{(1)} \cap \partial^e G_+ \cap \partial^e G_-\right) \setminus K\right) = 0. \quad (2.11)$$

Accordingly, we say that  $K$  *does not essentially disconnect*  $G$  if for every non-trivial Borel partition  $\{G_+, G_-\}$  of  $G$  modulo  $\mathcal{H}^m$  we have

$$\mathcal{H}^{m-1}\left(\left(G^{(1)} \cap \partial^e G_+ \cap \partial^e G_-\right) \setminus K\right) > 0. \quad (2.12)$$

Finally, we say that  $G$  is *essentially connected* if  $\emptyset$  does not essentially disconnect  $G$ . Note that the above definition is stable under modifications of  $K$  by  $\mathcal{H}^{m-1}$ -negligible sets, and of  $G$  by  $\mathcal{H}^m$ -negligible sets. We also mention that, when applied to sets of finite perimeter, essential connectedness coincides with the notion of indecomposability [11, Remark 2.3]. We recall that a set of finite perimeter  $G \subset \mathbb{R}^m$  is indecomposable (see [21, Definition 2.11] or [1, Section 4]), if for every non-trivial partition of  $G$  into sets of finite perimeter  $\{G_+, G_-\}$  modulo  $\mathcal{H}^m$ , we have that  $P(G) < P(G_+) + P(G_-)$ .

We conclude this section by observing that the notion of essential connectedness allows to express the indecomposability of  $F_v$  in terms of properties of its orthogonal projection  $\{v > 0\}$  on  $\mathbb{R}^{n-1}$ , see Theorem 3.17.

### 3. CHARACTERIZATION OF (SR)

This section is devoted to the study of rigidity for Steiner's inequality. In the following,  $\Omega$  will denote the orthogonal projection of  $F_v$  on  $\{y = 0\}$ , that is, we set  $\Omega := \{v > 0\}$ .

**3.1. Some auxiliary results.** We start by recalling some results that will be useful in the sequel. The following formula is a particular case of the coarea formula, see [2, formula (2.72)].

**Theorem 3.1** (Coarea formula). *Let  $E$  be a set of finite perimeter in  $\mathbb{R}^n$  and let  $g$  be any Borel function from  $\mathbb{R}^n$  to  $[0, \infty]$ . Then*

$$\int_{\partial^* E} g(x) |\nu_y^E(x)| d\mathcal{H}^{n-1}(x) = \int_{\mathbb{R}^{n-1}} dx' \int_{(\partial^* E)_{x'}} g(x', t) d\mathcal{H}^0(t).$$

We now state an adaptation of a theorem of Vol'pert [32] to the present setting (see [15, Theorem G], and [5, Theorem 2.4] for the case of higher codimensions).

**Theorem 3.2** (Vol'pert). *If  $E$  is a set of finite perimeter in  $\mathbb{R}^n$ , then for  $\mathcal{H}^{n-1}$ -a.e.  $x' \in \mathbb{R}^{n-1}$ :*

- (1)  $E_{x'}$  is a set of finite perimeter in  $\mathbb{R}$ ;
- (2)  $(\partial^* E)_{x'} = \partial^*(E_{x'})$ ;
- (3) for every  $t$  such that  $(x', t) \in (\partial^* E)_{x'} \cap \partial^*(E_{x'})$ :
  - (3a)  $\nu_y^E(x', t) \neq 0$ ;
  - (3b)  $\nu_y^E(x', t) = \nu_{x'}^{E_{x'}}(t) |\nu_y^E(x', t)|$ ;

*In particular, if  $E$  is  $v$ -distributed for some measurable function  $v : \mathbb{R}^{n-1} \rightarrow [0, \infty]$  satisfying (1.5), there exists a Borel set  $G_E \subset \{v > 0\}$  such that  $\mathcal{H}^{n-1}(\{v > 0\} \setminus G_E) = 0$  and properties (1)–(3) are satisfied for every  $x' \in G_E$ .*

Next lemma (see [15, Lemma 3.2]) gives the explicit expression of the absolutely continuous part of  $Dv$ .

**Lemma 3.3** (Cianchi, Chlebík, and Fusco). *Let  $v : \mathbb{R}^{n-1} \rightarrow [0, \infty]$  be a measurable function satisfying (1.5), and let  $E \subset \mathbb{R}^n$  be a  $v$ -distributed set. Then,*

$$\nabla v(x') = \int_{(\partial^* E)_{x'}} \frac{\nu_{x'}^E(x', t)}{|\nu_y^E(x', t)|} d\mathcal{H}^0(t), \quad \text{for } \mathcal{H}^{n-1}\text{-a.e. } x' \in G_E.$$

**3.2. Necessary conditions for equality cases.** De Giorgi was the first to address necessary conditions for equality cases of (SI). In [19] he showed that, if  $P(E) = P(F_v)$ , then for  $\mathcal{H}^{n-1}$ -a.e.  $x' \in \{v > 0\}$  the vertical section  $E_{x'}$  is a segment. Such result was later refined by Chlebík, Cianchi and Fusco, with the following theorem (see [15, Theorem 1.1]).

**Theorem 3.4** (Chlebík, Cianchi, and Fusco). *Let  $v : \mathbb{R}^{n-1} \rightarrow [0, \infty]$  be a measurable function satisfying (1.5), and let  $E \in \mathcal{M}(v)$ . Then, for  $\mathcal{H}^{n-1}$ -a.e.  $x' \in \Omega$  the following conditions are satisfied:*

- (1)  $E_{x'}$  is  $\mathcal{H}^1$ -equivalent to a segment  $(y_1(x'), y_2(x'))$ , for some  $y_1(x') \leq y_2(x')$ ;
- (2)  $(x', y_1(x')), (x', y_2(x')) \in \partial^* E$  with

$$\nu_{x'}^E(x', y_1(x')) = \nu_{x'}^E(x', y_2(x')) \quad \text{and} \quad \nu_y^E(x', y_1(x')) = -\nu_y^E(x', y_2(x')).$$

*Proof.* This proof is essentially a repetition of the steps in the proof of (SI), with a careful inspection of the equality cases. To ease the notation, we set  $F = F_v$ . By coarea formula, and using the fact that  $\nu^F$  is a unit vector

$$\begin{aligned} P(F; (G_F \cap G_E) \times \mathbb{R}) &= \int_{G_F \cap G_E} dx' \int_{(\partial^* F)_{x'}} \frac{1}{|\nu_y^F(x', t)|} d\mathcal{H}^0(t) \\ &= \int_{G_F \cap G_E} dx' \int_{(\partial^* F)_{x'}} \sqrt{1 + \sum_{i=1}^{n-1} \left( \frac{\nu_i^F(x', t)}{\nu_y^F(x', t)} \right)^2} d\mathcal{H}^0(t) \\ &= \int_{G_F \cap G_E} \sqrt{4 + |\nabla v(x')|^2} dx' \\ &= \int_{G_F \cap G_E} \sqrt{2^2 + \sum_{i=1}^{n-1} \left( \int_{\partial^*(E_{x'})} \frac{\nu_i^E(x', t)}{|\nu_y^E(x', t)|} d\mathcal{H}^0(t) \right)^2} dx', \end{aligned}$$

where we used Lemma 3.3 two times (once for  $F$ , and once for  $E$ ). Then, applying first the isoperimetric inequality in  $\mathbb{R}$  and then Jensen's inequality

$$\begin{aligned} &P(F; (G_F \cap G_E) \times \mathbb{R}) \\ &\leq \int_{G_F \cap G_E} \sqrt{\left( \int_{\partial^*(E_{x'})} d\mathcal{H}^0(t) \right)^2 + \sum_{i=1}^{n-1} \left( \int_{\partial^*(E_{x'})} \frac{\nu_i^E(x', t)}{|\nu_y^E(x', t)|} d\mathcal{H}^0(t) \right)^2} dx' \\ &\leq \int_{G_F \cap G_E} dx' \int_{\partial^*(E)_{x'}} \sqrt{1 + \sum_{i=1}^{n-1} \left( \frac{\nu_i^E(x', t)}{\nu_y^E(x', t)} \right)^2} d\mathcal{H}^0(t) \\ &= \int_{G_F \cap G_E} dx' \int_{(\partial^* E)_{x'}} \frac{1}{|\nu_y^E(x', t)|} d\mathcal{H}^0(t) \\ &= P(E; G_F \cap G_E), \end{aligned}$$

where we used again coarea formula and the fact that  $\nu^E$  is a unit vector. Observe now that, combining (SI) and the assumption  $P(E) = P(F)$ , we obtain

$$P(E; B \times \mathbb{R}) = P(F; B \times \mathbb{R}) \quad \text{for every Borel set } B \subset \mathbb{R}^{n-1}.$$

In particular, using the above equality with  $B = G_F \cap G_E$ , we infer that all the inequalities in the previous chain have to be equalities. Since the only equality cases for the isoperimetric inequality in  $\mathbb{R}$  are segments, we obtain (1). Moreover, Jensen's inequality above becomes an equality if and only if for  $\mathcal{H}^{n-1}$ -a.e.  $x' \in G_E$

$$t \longmapsto \frac{\nu_i^E(x', t)}{|\nu_y^E(x', t)|} \text{ is constant in } \partial^*(E_{x'}), \quad \text{for every } i = 1, \dots, n-1.$$

Since by (1) it is  $E_{x'} = (y_1(x'), y_2(x'))$ , we have

$$\frac{\nu_i^E(x', y_1(x'))}{|\nu_y^E(x', y_1(x'))|} = \frac{\nu_i^E(x', y_2(x'))}{|\nu_y^E(x', y_2(x'))|} \quad \text{for every } i = 1, \dots, n-1. \quad (3.1)$$

Using the fact that  $\nu^E$  is a unitary vector,

$$\begin{aligned} \frac{1}{|\nu_y^E(x', y_1(x'))|^2} &= 1 + \sum_{i=1}^{n-1} \left( \frac{\nu_i^E(x', y_1(x'))}{\nu_y^E(x', y_1(x'))} \right)^2 \\ &= 1 + \sum_{i=1}^{n-1} \left( \frac{\nu_i^E(x', y_2(x'))}{\nu_y^E(x', y_2(x'))} \right)^2 = \frac{1}{|\nu_y^E(x', y_2(x'))|^2}, \end{aligned}$$

which gives

$$|\nu_y^E(x', y_1(x'))| = |\nu_y^E(x', y_2(x'))|, \quad \text{for } \mathcal{H}^{n-1}\text{-a.e. } x' \in G_E. \quad (3.2)$$

Plugging this in (3.1) we get

$$\nu_i^E(x', y_1(x')) = \nu_i^E(x', y_2(x')).$$

Finally, from (3b) of Theorem 3.2 we have  $\nu^{E_{x'}}(y_1(x')) < 0 < \nu^{E_{x'}}(y_2(x'))$  (recall that  $\nu^{E_{x'}}$  denotes the *exterior* unit normal to  $E_{x'}$ ), and

$$\begin{cases} \nu_y^E(x', y_1(x')) = \nu^{E_x}(y_1(x')) |\nu_y^E(x', y_1(x'))| < 0, \\ \nu_y^E(x', y_2(x')) = \nu^{E_x}(y_2(x')) |\nu_y^E(x', y_2(x'))| > 0, \end{cases}$$

which, together with (3.2), gives

$$\nu_y^E(x', y_1(x')) = -\nu_y^E(x', y_2(x')).$$

□

**3.3. Sufficient conditions for (SR) by Chlebík, Cianchi, and Fusco.** In this subsection we discuss the sufficient conditions for rigidity in Steiner's inequality given in [15]. We start by showing that rigidity can fail even when the necessary conditions of Theorem 3.4 are satisfied. This can happen for three main reasons:

- (i) the projection  $\Omega$  of  $F_v$  could be disconnected;
- (ii) the boundary of  $F_v$  may contain “flat vertical parts”;
- (iii) the set  $\{v = 0\}$  disconnects  $\Omega$ .

Let us start by commenting on situation (i). Figure 1.2 shows the example of a set  $E \in \mathcal{M}(v)$  which is not obtained by a vertical translation of  $F_v$ . This is possible because the projection  $\Omega$  of  $F_v$  is the union of two disjoint intervals. To prevent this from happening, one can impose the following:

- (A) the projection  $\Omega$  of  $F_v$  is  $\mathcal{H}^{n-1}$ -equivalent to an open and connected set.

Although (A) certainly avoids counterexamples as the ones shown in Figure 1.2, this is not enough to have rigidity. In Figure 1.3, the projection of  $F_v$  is equivalent to an open bounded interval, so (A) is satisfied. However, the presence of “flat vertical parts” in the boundary of  $F_v$  allows to vertically shift a subset of  $F_v$  (the triangle on the right end of  $F_v$ , in this case), without modifying its perimeter. In a more rigorous way, one can identify the flat vertical parts of the boundary of  $F_v$  with the set of those points  $(x', y) \in \partial^* F_v$  such that the exterior unit normal  $\nu^{F_v}(x', y)$  to  $\partial^* F_v$  is horizontal:

$$\{(x', y) \in \partial^* F_v : \nu_y^{F_v}(x', y) = 0\}.$$

Note that, in order to rule out the last counterexample, we only need to focus on the open stripe  $\Omega \times \mathbb{R}$  (in fact, the flat vertical parts on the left side of  $\partial^* F_v$  are “harmless”). Therefore, one is lead to impose the condition

$$\mathcal{H}^{n-1}((\Omega \times \mathbb{R}) \cap \{(x', y) \in \partial^* F_v : \nu_y^{F_v}(x', y) = 0\}) = 0. \quad (3.3)$$

Interestingly, condition (3.3) is equivalent to asking that the function  $v$  (which, as mentioned in Lemma 1.3, is in general only  $BV$ ) belongs to the Sobolev space  $W^{1,1}(\Omega)$  (see [15, Proposition 1.2]). In the situation depicted in Figure 1.3, such condition is violated, since the jump part  $D^j v$  of  $Dv$  is nonzero, and is concentrated at the point  $\bar{x}$ . Therefore, the second condition we will impose is

$$(B) \quad v \in W^{1,1}(\Omega).$$

Observe that condition (B) can also be violated when  $Dv$  has a nontrivial Cantor part, that is, when  $D^c v \neq 0$ , as explained in the next example.

**Example 3.5.** Let  $n = 2$ , and let  $v : \mathbb{R} \rightarrow [0, \infty)$  be given by

$$v(x') = \begin{cases} 2(1 - c(|x'|)) & \text{if } |x'| < 1, \\ 0 & \text{otherwise,} \end{cases} \quad (3.4)$$

where  $c : [0, 1] \rightarrow [0, 1]$  is the standard Cantor function. Then,

$$F_v = \{(x', y) \in \mathbb{R}^2 : |x'| < 1 \text{ and } |y| < 1 - c(|x'|)\}.$$

One can check that if  $F_v$  is the set given above rigidity is violated, since

$$P(E) = P(F_v),$$

where  $E$  is the  $v$ -distributed set given by

$$E = \{(x', y) \in \mathbb{R}^2 : |x'| < 1 \text{ and } 0 < |y| < 2(1 - c(|x'|))\}.$$

In this case, even though the jump part  $D^j v$  of  $Dv$  vanishes, the set  $\partial^* F_v$  still exhibits “infinitesimal flat vertical parts”. More precisely one could prove that, if  $v$  is given by (3.4), then (here  $K$  denotes the Cantor set in  $[0, 1]$ ):

$$\begin{aligned} & \mathcal{H}^1(((-1, 1) \times \mathbb{R}) \cap \{(x', y) \in \partial^* F_v : \nu_y^{F_v}(x', y) = 0\}) \\ &= \mathcal{H}^1(\{(x', \pm(1 - c(x')))) : x' \in K\} \cup \{(-x', \pm(1 - c(x')))) : x' \in K\}) = 4 > 0, \end{aligned}$$

so that (3.3) (and therefore (B)) is violated.

Even when (A) and (B) are satisfied, it is still possible to violate rigidity. In Figure 3.1, the projection  $\Omega = \{v > 0\}$  of  $F_v$  is  $\mathcal{H}^1$ -equivalent to a connected segment (so (A) is satisfied) and the boundary of  $F_v$  does not contain flat vertical parts (so that (B) holds true). However, we have  $v(\hat{x}) = 0$ , for some point  $\hat{x}$  that lies inside  $\Omega$ . This allows to “disconnect” the set  $F_v$  into two sets, without changing its perimeter. In order to prevent such situation, one could try to impose the following:

$$v > 0 \text{ in } \Omega. \quad (3.5)$$

Unfortunately, condition (3.5) is not stable under change of the representative of  $v$ . Indeed, we can make sure that (3.5) holds true by simply modifying the function  $v$  of the previous example at the point  $\hat{x}$ , see Figure 3.2. As shown in the figure, also in this case rigidity is violated. This problem can be overcome by taking advantage of condition (B). Indeed, whenever  $v \in W^{1,1}(\Omega)$  there exists a Lebesgue representative  $\tilde{v}$  of  $v$ , which is defined  $\mathcal{H}^{n-2}$ -a.e. in  $\Omega$ . Therefore, we can state condition (3.5) in a more rigorous way, by requiring

$$(C) \quad \tilde{v}(x') > 0 \text{ for } \mathcal{H}^{n-2}\text{-a.e. } x' \in \Omega.$$

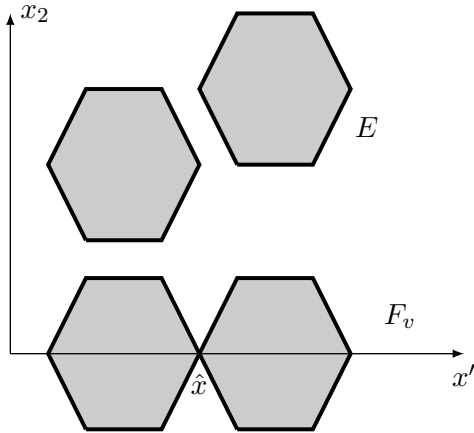

FIGURE 3.1. An example when situation (iii) occurs.

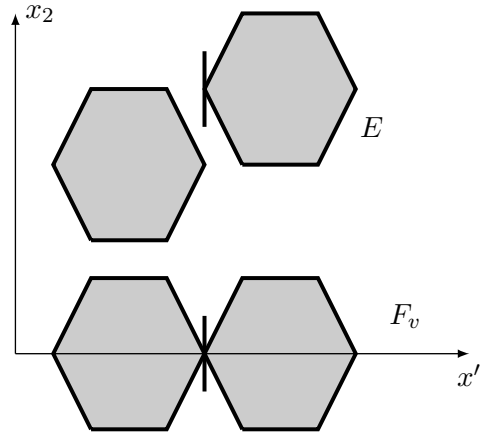

FIGURE 3.2.  $v > 0$  in  $\Omega$ , but rigidity fails.

Note that condition (C) rules out the counterexamples in Figure 3.1 and Figure 3.2. Indeed, one can check that in these cases  $\tilde{v}(\hat{x}) = 0$ , with  $\mathcal{H}^0(\hat{x}) = 1 > 0$ .

In 2005, Chlebík, Cianchi and Fusco showed that (A), (B), and (C) are sufficient conditions for rigidity [15, Theorem 1.3].

**Theorem 3.6** (Chlebík, Cianchi, and Fusco). *Suppose conditions (A), (B), and (C) are satisfied. Then, (SR) holds true.*

**3.4. Comments on conditions (A), (B), and (C).** As the examples given in Figure 1.3, Figure 3.1, and Figure 3.2 show, conditions (A), (B), and (C) seem to be quite reasonable requirements in order to have rigidity. We are therefore naturally lead to ask the following question:

Are (A), (B), and (C) also *necessary* for rigidity?

Let us first address condition (B). Figure 3.3 shows a polyhedron  $F_v \subset \mathbb{R}^3$  whose boundary has “flat vertical parts”. As we have already observed, this is equivalent to having  $v \notin$

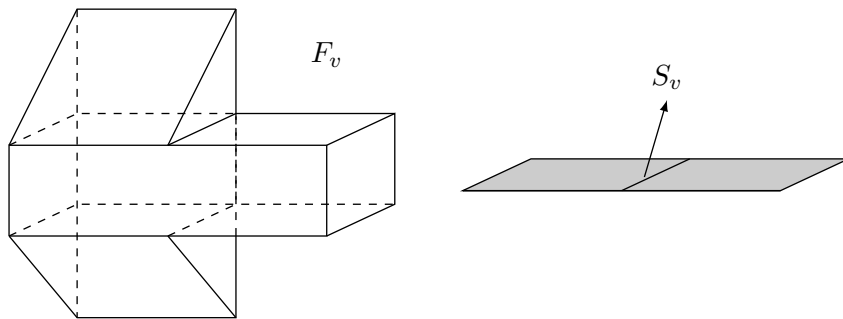

FIGURE 3.3. For the set  $F_v$  above condition (B) fails, but rigidity is still true. This shows that (B) is not necessary. The right part of the figure shows the projection  $\Omega$  of  $F_v$ , and the jump set  $S_v$  of  $v$ .

$W^{1,1}(\Omega)$ . In particular, in this example condition (B) is violated since the jump part  $D^j v$  of  $Dv$  is non zero, and is supported in the set  $S_v$  depicted in the (right part of the) figure. One can check that in this case (SR) still holds true, and this shows that *condition (B) is not necessary for rigidity*. We therefore need to understand how to treat rigidity in presence of jumps or Cantorian parts of  $Dv$ .

Let us now discuss condition (C). Figure 3.4 shows a polyhedral set  $F_v$  for which (C) fails (since  $\mathcal{H}^1(\Omega \cap \{\tilde{v} = 0\}) > 0$ ), but rigidity holds true. Therefore, *condition (C) is not necessary for rigidity*.

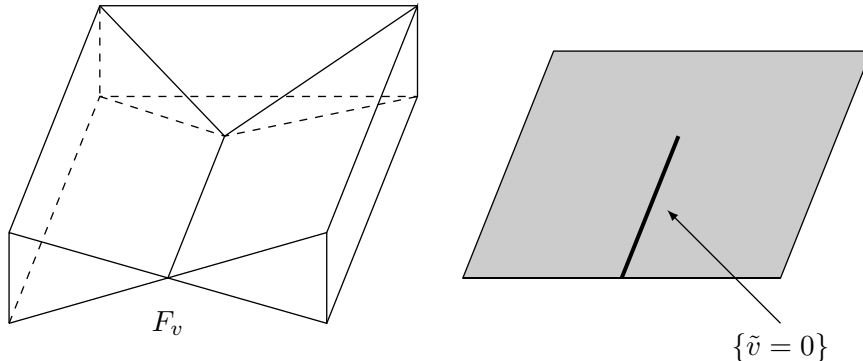

FIGURE 3.4. A polyhedron for which condition (C) fails, but rigidity still holds true.

Finally, note that also *condition (A) is not necessary*. Indeed, the projection  $\Omega$  of  $F_v$  is given by the superlevel set  $\{v > 0\}$  of the function  $v$ . If  $v$  satisfies the minimal assumption (1.5), we can only expect  $\{v > 0\}$  to be a Borel subset of  $\mathbb{R}^{n-1}$ , and there is no reason for it to be  $\mathcal{H}^{n-1}$ -equivalent to an open set. Note also that, if we remove the assumption that  $\{v > 0\}$  is open, it is not even clear how to require this set to be connected.

**3.5. The barycenter function.** The comments above show that, when looking for necessary and sufficient conditions for rigidity, one needs to refine conditions (A), (B) and (C). To this aim, let us start by making an important observation. Thanks to Theorem 3.4, in order to study equality cases of (SI), one needs to focus on sets  $E$  whose vertical sections  $E_{x'}$  are segments for  $\mathcal{H}^{n-1}$ -a.e.  $x' \in \mathbb{R}^{n-1}$ . In order to give a description of the fine properties of these sets, we introduce the *barycenter* function.

**Definition 3.7.** *Let  $v : \mathbb{R}^{n-1} \rightarrow [0, \infty]$  be a measurable function satisfying (1.5), and let  $E \subset \mathbb{R}^n$  be a  $v$ -distributed set satisfying condition (1) of Theorem 3.4. We define the barycenter of  $E$  as*

$$b_E(x') := \begin{cases} \frac{1}{v(x')} \int_{E_{x'}} t \, d\mathcal{H}^1(t) & \text{if } 0 < v(x') < \infty, \\ 0 & \text{otherwise.} \end{cases}$$

The importance of the barycenter function lies in the fact that, once  $v$  satisfying (1.5) is given, condition (1) of Theorem 3.4 implies that every set  $E \in \mathcal{M}(v)$  is uniquely determined by its barycenter function  $b_E$ . In particular, showing rigidity amounts to show the following implication:

$$E \in \mathcal{M}(v) \implies b_E \text{ is constant } \mathcal{H}^{n-1}\text{-a.e. in } \{v > 0\}.$$

To prove that  $b_E$  is  $\mathcal{H}^{n-1}$ -a.e. constant, one could try to show that its (distributional) gradient vanishes in  $\{v > 0\}$ . This strategy has been followed in [5], under assumptions (A), (B), and (C). More precisely, in [5, Theorem 4.3] the following regularity result is proved (a weaker result is shown to hold for the Steiner symmetrisation in higher codimension).

**Theorem 3.8.** *Let  $v : \mathbb{R}^{n-1} \rightarrow [0, \infty]$  be a measurable function satisfying (1.5), and let  $E \subset \mathbb{R}^n$  be a  $v$ -distributed set satisfying condition (1) of Theorem 3.4. Suppose that (A),*



(B), and (C) are satisfied. Then,  $b_E \in W_{loc}^{1,1}(\{v > 0\})$  and for  $\mathcal{H}^{n-1}$ -a.e.  $x' \in \{v > 0\}$

$$\nabla b_E(x') = \frac{1}{v(x')} \int_{\partial^* E_{x'}} (y - b_E(x')) \frac{\nu_{x'}^E(x', y)}{|\nu_y^E(x', y)|} d\mathcal{H}^0(y).$$

Once the formula above is established, thanks to (2) of Theorem 3.4 one obtains that  $\nabla b_E \equiv 0$  for every  $E \in \mathcal{M}(v)$ , thus showing rigidity. In particular, this gives an alternative proof of Theorem 3.6.

When conditions (A), (B), and (C) are not satisfied the barycenter can be quite irregular, as the next two examples shows (see [5, Remark 3.5]).

**Example 3.9.** Let  $n = 2$  and let  $E \subset \mathbb{R}^2$  be given by

$$E = \bigcup_{h \in \mathbb{N}} \left\{ (x', y) \in \mathbb{R}^2 : \frac{1}{h+1} < |x'| < \frac{1}{h}, |y - (-1)^h| < \frac{1}{h^2} \right\}.$$

In this case, the vertical sections of  $E$  are segments,  $P(E) < \infty$ , and  $b_E \in L^\infty(\mathbb{R})$ . However,  $b_E \notin BV(\mathbb{R})$ .

**Example 3.10.** Let  $n = 3$ , and let  $E \subset \mathbb{R}^3$  be given by

$$E = \bigcup_{h \in \mathbb{N}} \left\{ (x', y) \in \mathbb{R}^3 : \frac{1}{(h+1)^2} < |x'| < \frac{1}{h^2}, |y - h^4| < \frac{1}{2} \right\}.$$

In this case, the vertical sections of  $E$  are segments, and  $P(E) < \infty$ . However, we have  $b_E \notin L_{loc}^1(\mathbb{R}^2)$ , since

$$b_E(x') = \sum_{h \in \mathbb{N}} \chi_{((h+1)^{-2}, h^{-2})}(|x'|) h^4.$$

Thus,  $b_E$  does not admit distributional derivative.

In Example 3.9 the barycenter loses regularity because it oscillates very rapidly when the independent variable  $x'$  approaches the set  $\{v = 0\}$ . Instead, in Example 3.10 problems arise since the set  $E$  is allowed to “escape” at infinity still keeping the perimeter finite. The optimal regularity of the barycenter is given by the following result, see [10, Theorem 1.7].

**Theorem 3.11.** Let  $v : \mathbb{R}^{n-1} \rightarrow [0, \infty]$  be a measurable function satisfying (1.5), and let  $E \subset \mathbb{R}^n$  be a  $v$ -distributed set satisfying condition (1) of Theorem 3.4. Then,

$$b_E \chi_{\{v > \delta\}} \in GBV(\mathbb{R}^{n-1}),$$

for every  $\delta > 0$  such that  $\{v > \delta\}$  is a set of finite perimeter in  $\mathbb{R}^{n-1}$ .

Using the theorem above, it is possible to prove a formula for the perimeter of sets whose vertical sections are segments, in terms of  $v$  and  $b_E$ , see [10, Theorem B.1].

**Theorem 3.12.** Let  $v : \mathbb{R}^{n-1} \rightarrow [0, \infty]$  be a measurable function satisfying (1.5), and let  $E \subset \mathbb{R}^n$  be a  $v$ -distributed set satisfying condition (1) of Theorem 3.4. Then,

$$\begin{aligned} P(E) &= \int_{\{v > 0\}} \sqrt{1 + |\nabla u_1|^2} + \sqrt{1 + |\nabla u_2|^2} d\mathcal{H}^{n-1} \\ &\quad + \int_{S_v \cup S_{b_E}} \min\{v^\vee + v^\wedge, \max\{[v], 2[b_E]\}\} d\mathcal{H}^{n-2} \\ &\quad + |D^c u_1|^+(\{v^\wedge > 0\}) + |D^c u_2|^+(\{v^\vee > 0\}), \end{aligned} \tag{3.6}$$

where  $u_1 = b_E - \frac{1}{2}v$ ,  $u_2 = b_E + \frac{1}{2}v$  and, for every Borel set  $G \subset \mathbb{R}^{n-1}$ ,

$$|D^c u_i|^+(G) := \lim_{h \rightarrow \infty} |D^c(\chi_{\Sigma_h} u_i)|^+(G) \quad i = 1, 2.$$

In the formula above,  $\Sigma_h := \{\delta_h < v < L_h\}$  where  $(\delta_h)_{h \in \mathbb{N}}$  and  $(L_h)_{h \in \mathbb{N}}$  are sequences such that  $\delta_h \rightarrow 0$ ,  $L_h \rightarrow \infty$ , and  $\{v > \delta_h\}$  and  $\{v < L_h\}$  are sets of finite perimeter in  $\mathbb{R}^{n-1}$  for every  $h \in \mathbb{N}$ .

**3.6. Characterisation of equality cases and a sufficient conditions for (SR).** Theorem 3.12 can now be used to characterise the equality cases of (SI). Indeed, denoting the right hand side of (3.6) by  $\mathcal{F}(v, b_E)$ , and using the fact that  $b_{F_v} \equiv 0$ , we have

$$E \in \mathcal{M}(v) \iff \mathcal{F}(v, b_E) = \mathcal{F}(v, 0).$$

Imposing the equality above we obtain the following result, which gives a complete characterisation of  $\mathcal{M}(v)$  in full generality.

**Theorem 3.13.** *Let  $v : \mathbb{R}^{n-1} \rightarrow [0, \infty]$  be a measurable function satisfying (1.5), and let  $E$  be a  $v$ -distributed set of finite perimeter. Then,  $E \in \mathcal{M}(v)$  if and only if*

$$E_{x'} \text{ is } \mathcal{H}^1\text{-equivalent to a segment,} \quad \text{for } \mathcal{H}^{n-1}\text{-a.e. } x' \in \mathbb{R}^{n-1}, \quad (3.7)$$

$$\nabla b_E(x') = 0, \quad \text{for } \mathcal{H}^{n-1}\text{-a.e. } x' \in \mathbb{R}^{n-1}, \quad (3.8)$$

$$2[b_E] \leq [v], \quad \mathcal{H}^{n-2}\text{-a.e. on } \{v^\wedge > 0\}, \quad (3.9)$$

$$D^c(b_\delta^M)(G) = \int_{G \cap \{v > \delta\}^{(1)} \cap \{b_E < M\}^{(1)}} f d(D^c v), \quad \text{for every bounded Borel set } G \subset \mathbb{R}^{n-1} \quad (3.10)$$

and for  $\mathcal{H}^1$ -a.e.  $\delta > 0$  and  $M > 0$ ,

where  $f : \mathbb{R}^{n-1} \rightarrow [-1/2, 1/2]$  is a Borel function, and we set  $b_\delta^M = \tau_M(b_E \chi_{\{v > \delta\}})$ . In particular,  $E \in \mathcal{M}(v)$  implies that

$$2|D^c b_E|^+(G) \leq |D^c v|(G), \quad \text{for every Borel set } G \subset \mathbb{R}^{n-1}, \quad (3.11)$$

where

$$|D^c b_E|^+(G) := \lim_{h \rightarrow \infty} |D^c(\chi_{\{v > \delta_h\}} b_E)|^+(G)$$

for every Borel set  $G \subset \mathbb{R}^{n-1}$  and the sequence  $(\delta_h)_{h \in \mathbb{N}}$  is as in Theorem 3.12.

In order to clarify the conditions above, we give now some examples. Figure 3.5 and Figure 3.6 show two sets that violate (3.7) and (3.8), respectively, while Figure 3.7 clarifies why condition (3.9) is needed.

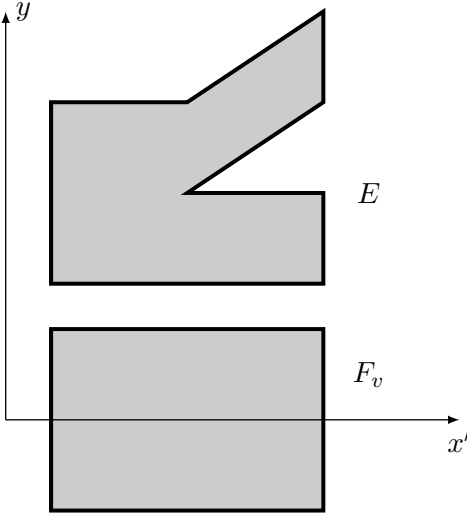

FIGURE 3.5.  $E \notin \mathcal{M}(v)$ , since (3.7) is violated.

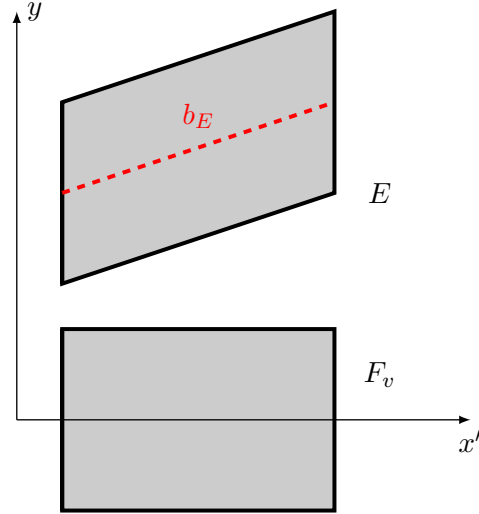

FIGURE 3.6.  $E \notin \mathcal{M}(v)$ , since (3.8) is violated.

Note that inequality  $2[b_E] \leq [v]$  is not required at those points where  $v^\wedge = 0$ , see Figure 3.8. An inequality similar to (3.9) holds for the Cantor parts of the measures associated to  $b_E$  and  $v$ , see (3.11). More precisely, the measure  $|D^c b_E|^+$  is absolutely continuous with respect to  $D^c v \llcorner \{v^\wedge > 0\}$ . Note that, in particular, if  $E \in \mathcal{M}(v)$  there is no control on the Cantor part of  $D b_E$  (or  $|D^c b_E|^+$ , when  $b_E$  is not BV) in the set  $\{v^\wedge = 0\}$ , as explained in Example 3.14 below (see also [10, Remark 1.31]).

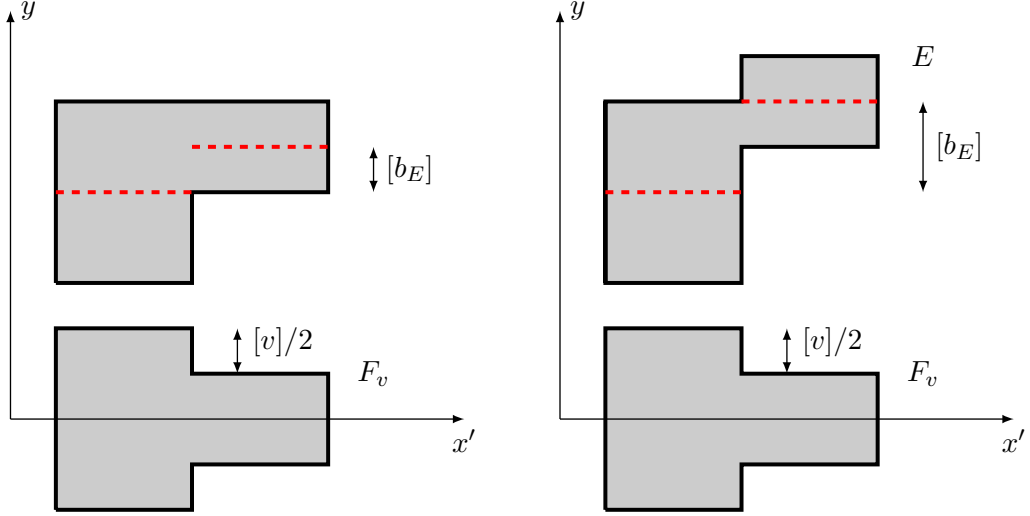

FIGURE 3.7. In order to have  $E \in \mathcal{M}(v)$  we need  $[b_E] \leq [v]/2$ . The set  $E$  in the left hand side is such that  $[b_E] = [v]/2$  (the dashed red line represents  $b_E$ ), and we still have  $P(E) = P(F_v)$ . In the right hand side, the set  $E$  is such that  $[b_E] > [v]/2$ , and therefore  $P(E) > P(F_v)$ .

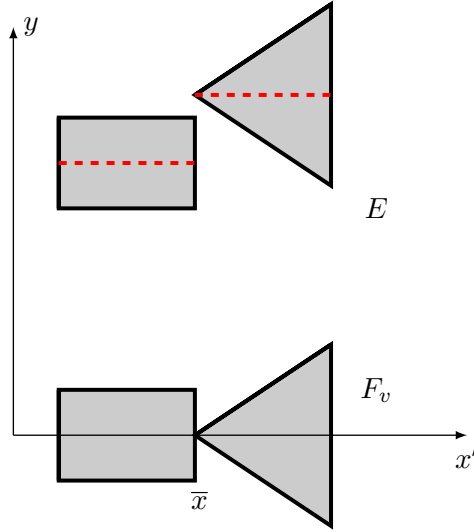

FIGURE 3.8. Inequality  $2[b_E] \leq [v]$  is not required in  $\{v^\wedge = 0\}$ . The set  $E$  in the picture satisfies  $2[b_E] > [v]$  at a point  $\bar{x} \in \{v^\wedge = 0\}$ , but we still have  $E \in \mathcal{M}(v)$ .

**Example 3.14.** We show now an example in which  $D^c v = 0$ , but there exists a set  $E \in \mathcal{M}(v)$  whose barycenter is a function of bounded variation with non trivial Cantor part. Thanks to condition (3.11) and recalling the definition of  $|D^c b_E|^+$ , this is only possible if  $D^c b_E$  is concentrated in the set  $\{v^\wedge = 0\}$ . Let  $n = 2$ , let  $K \subset \mathbb{R}$  be the standard Cantor set and let  $c : [0, 1] \rightarrow \mathbb{R}$  denote the Cantor function in  $[0, 1]$ . We set

$$v(x') := \begin{cases} 2 \operatorname{dist}(x', K) & \text{if } x' \in (0, 1), \\ 0 & \text{otherwise,} \end{cases}$$

where “dist” stands for the distance function. Note that  $v$  is Lipschitz continuous, and in particular  $D^c v = 0$ . Consider now the  $v$ -distributed set  $E$  such that  $b_E(x') = c(x')$ . A pictorial idea of the sets  $F_v$  and  $E$  is given in Figure 3.9. In this case,  $E \in \mathcal{M}(v)$  and

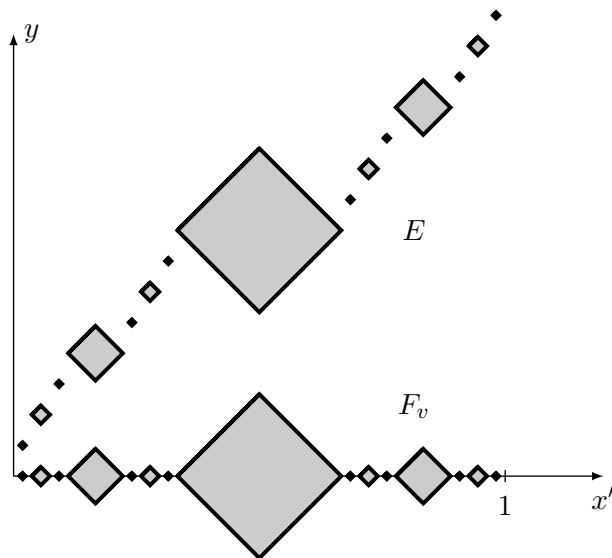

FIGURE 3.9. A pictorial idea of the set described in Example 3.14. In this case  $v$  is Lipschitz continuous, and therefore  $D^c v = 0$ . However, there exists a set  $E \in \mathcal{M}(v)$  with  $D^c b_E \neq 0$ . This does not violate the characterization Theorem 3.7 (and, in particular, conditions (3.10) and (3.11)), since  $D^c b_E$  is concentrated in the set  $\{v^\wedge = 0\}$ .

$D^c b_E$  is non trivial (in fact,  $Db_E$  is purely Cantorian), despite  $D^c v = 0$ . This is obtained by concentrating  $D^c b_E$  in the set  $\{v^\wedge = 0\}$ . More precisely, we have  $D^c b_{E \setminus \{v^\wedge = 0\}} \neq 0$ , but  $|D^c b_E|^+ = 0$ . In this way, conditions (3.10) and (3.11) are not violated.

We conclude this subsection with a sufficient condition for rigidity that improves Theorem 3.6.

**Theorem 3.15.** *Let  $v : \mathbb{R}^{n-1} \rightarrow [0, \infty]$  be a measurable function satisfying (1.5), and suppose that the Cantor part  $D^c v$  of  $Dv$  is concentrated on a Borel set  $K$  such that*

$$\{v^\wedge = 0\} \cup S_v \cup K \text{ does not essentially disconnect } \{v > 0\}. \quad (3.12)$$

*Then, (SR) holds true.*

**Remark 3.16.** *Note that assumptions (A), (B), and (C) of Theorem 3.6 imply that*

$$S_v =_{\mathcal{H}^{n-2}} \emptyset, \quad \text{and} \quad \{v^\wedge = 0\} \cap \{v > 0\}^{(1)} =_{\mathcal{H}^{n-2}} \emptyset,$$

*and that one can choose  $K = \emptyset$ , so that (3.12) is trivially satisfied.*

**3.7. Geometric Characterizations of (SR).** Theorem 3.13 turns out to be a very useful tool to show geometric characterizations of rigidity in several situations. First of all, let us observe that the notion of essential connectedness is fundamental if one wants to express the indecomposability of  $F_v$  in terms of properties of its orthogonal projection on  $\mathbb{R}^{n-1}$  (see [10, Remark 1.17]).

**Theorem 3.17.** *Let  $v : \mathbb{R}^{n-1} \rightarrow [0, \infty]$  be a measurable function satisfying (1.5). Then the following are equivalent:*

- (i)  $F_v$  is indecomposable;
- (ii)  $\{v^\wedge = 0\}$  does not essentially disconnect  $\{v > 0\}$ .

We can now start studying geometric characterizations of (SR). We start by considering the case in which there are no “flat vertical parts” in  $\partial^* F_v$ . In full generality, such situation is described by condition (3.13) below, which is more general than (B) (since it does not

require  $\{v > 0\}$  to be open). Next result shows that, under this assumption, rigidity fails if and only if  $F_v$  is decomposable (see Figure 3.1 and Figure 3.2). For a proof, see [10, Theorem 1.16].

**Theorem 3.18.** *Let  $v : \mathbb{R}^{n-1} \rightarrow [0, \infty]$  be a measurable function satisfying (1.5). Suppose, in addition, that*

$$D^s v_{\perp} \{v^{\wedge} > 0\} = 0. \quad (3.13)$$

*Then the following are equivalent:*

- (i) (SR) holds true;
- (ii)  $F_v$  is indecomposable;
- (iii)  $\{v^{\wedge} = 0\}$  does not essentially disconnect  $\{v > 0\}$ .

**Remark 3.19.** *Note that, as already clarified by Theorem 3.17, conditions (ii) and (iii) are always equivalent, even when (3.13) is not satisfied.*

We now consider a situation more general than the one discussed in Theorem 3.18. Roughly speaking, we will assume that  $F_v$  is a finite union of “regular” sets. A rigorous argument requires the following definition.

**Definition 3.20.** *Let  $v : \mathbb{R}^{n-1} \rightarrow [0, \infty]$  be a measurable function satisfying (1.5). The set  $F_v$  is said to be a generalized polyhedron if there exists a finite disjoint family of indecomposable sets of finite perimeter and volume  $\{A_j\}_{j \in J}$  in  $\mathbb{R}^{n-1}$ , and a family of functions  $\{v_j\}_{j \in J} \subset W^{1,1}(\mathbb{R}^{n-1})$ , such that*

$$v = \sum_{j \in J} v_j 1_{A_j}, \quad (3.14)$$

$$\left( \{v^{\wedge} = 0\} \setminus \{v = 0\}^{(1)} \right) \cup S_v \subset_{\mathcal{H}^{n-2}} \bigcup_{j \in J} \partial^e A_j. \quad (3.15)$$

**Remark 3.21.** *Roughly speaking, the set  $\{v = 0\}^{(1)}$  represents the complement of the (orthogonal) projection of  $F_v$  on  $\mathbb{R}^{n-1}$ . Therefore, condition (3.15) makes sure that the function  $v$  can only vanish or jump on the essential boundaries of the sets  $A_j$ .*

We are now ready to state a geometric characterisation of rigidity when  $F_v$  is a generalized polyhedron, see [10, Theorem 1.20]

**Theorem 3.22.** *If  $v : \mathbb{R}^{n-1} \rightarrow [0, \infty]$  is such that  $F_v$  is a generalized polyhedron, then the following two statements are equivalent:*

- (i) (SR) holds true;
- (ii) for every  $\varepsilon > 0$  the set  $\{v^{\wedge} = 0\} \cup \{[v] > \varepsilon\}$  does not essentially disconnect  $\{v > 0\}$ .

**Remark 3.23.** *The theorem above shows that, when  $F_v$  is “piecewise regular”, requiring that  $S_v$  essentially disconnects  $\{v > 0\}$  is not sufficient for the failure of (SR). This is clarified by Figure 3.3 where, although  $S_v$  essentially disconnects  $\{v > 0\}$ , we still have rigidity. This is because there is no  $\varepsilon$  such that  $\{v^{\wedge} = 0\} \cup \{[v] > \varepsilon\}$  essentially disconnects  $\{v > 0\}$ , and so condition (ii) above is satisfied. Figure 3.10 instead shows an example in which rigidity fails, since there exists  $\varepsilon > 0$  such that the set  $\{[v] > \varepsilon\}$  (so, in particular,  $\{v^{\wedge} = 0\} \cup \{[v] > \varepsilon\}$ ) essentially disconnects  $\{v > 0\}$ .*

The previous two theorems seem to suggest that rigidity fails if and only if one can exhibit a set  $E \in \mathcal{M}(v)$  obtained by performing a single vertical translation of a proper subset of  $F_v$ , see for instance Figure 3.1 and Figure 3.10. However, in more general situations things can be much more complicated. Indeed, one can have loss of rigidity even when condition (ii) of Theorem 3.22 is satisfied. That is, rigidity can fail even if there is no  $\varepsilon > 0$  such that the set  $\{v^{\wedge} = 0\} \cup \{[v] > \varepsilon\}$  essentially disconnects  $\{v > 0\}$ .

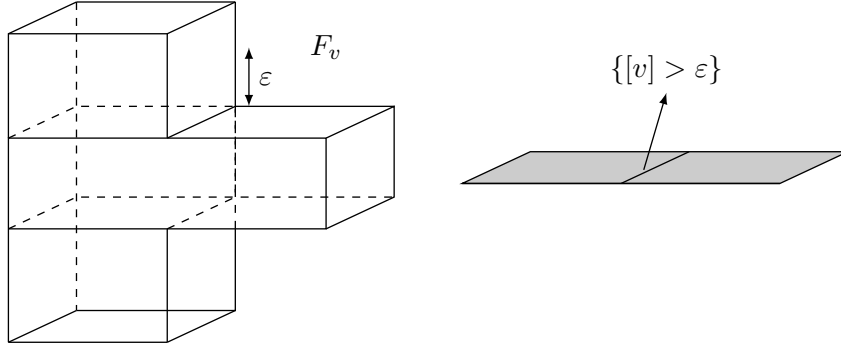

FIGURE 3.10.  $F_v$  is a (generalized) polyhedron and rigidity fails, since condition (ii) of Theorem 3.22 is violated.

The example below (see [10, Example 1.22]), shows a set  $E \in \mathcal{M}(v)$  that can be obtained by performing infinitely many vertical translations, each on a different subset of  $F_v$ . Note that in this example it is not possible to construct a set  $E \subset \mathcal{M}(v)$  by vertically translating only a *finite* number of proper subsets of  $F_v$ .

**Example 3.24.** *We will now show that we can have loss of rigidity even when condition (ii) of Theorem 3.22 is satisfied. For each  $t \in \mathbb{R}$  and  $\ell > 0$ , we denote by  $Q(t, \ell)$  the open square in  $\mathbb{R}^2$  centered at  $(t, 0)$ , with sides parallel to the directions  $(1, 1)$  and  $(1, -1)$ , and whose diagonal has length  $2\ell$ . We now define the sequence  $(u_k)_{k \in \mathbb{N}}$  of piecewise constant functions in the following way. We set  $u_1 = \chi_{Q(0,1)}$  and then*

$$\begin{aligned} u_2 &= u_1 - \frac{1}{2}\chi_{Q(-3/4,1/4)} + \frac{1}{2}\chi_{Q(3/4,1/4)}, \\ u_3 &= u_2 - \frac{1}{4}\chi_{Q(-15/16,1/16)} + \frac{1}{4}\chi_{Q(-9/16,1/16)} - \frac{1}{4}\chi_{Q(9/16,1/16)} + \frac{1}{4}\chi_{Q(15/16,1/16)}, \end{aligned}$$

and so on by induction, see Figure 3.11. We then define  $v : \mathbb{R}^2 \rightarrow [0, \infty)$  as the pointwise limit of the sequence  $(u_k)_{k \in \mathbb{N}}$ :

$$v(x') := \lim_{k \rightarrow \infty} u_k(x') \quad \text{for } \mathcal{H}^2\text{-a.e. } x' \in \mathbb{R}^2.$$

One can check that condition (ii) of Theorem 3.22 is satisfied. However, setting

$$E := \{(x', t) \in \mathbb{R}^3 : 0 < t < v(x')\}$$

we have  $E \in \mathcal{M}(v)$ , so that rigidity fails. Note that this example does not satisfy the assumptions of by Theorem 3.22, since  $F_v$  is not a generalized polyhedron.

In order to tackle situations as the one described in Example 3.24 above, we need the following definitions (see [10, Definition 1.23 and Definition 1.25]).

**Definition 3.25.** *Let  $G \subset \mathbb{R}^{n-1}$  be a set of finite perimeter, and let  $\{G_h\}_{h \in I}$  be an at most countable Borel partition of  $G$  modulo  $\mathcal{H}^{n-1}$ . We say that  $\{G_h\}_{h \in I}$  is a Caccioppoli partition of  $G$ , if  $\sum_{h \in I} P(G_h) < \infty$ .*

**Definition 3.26.** *Let  $v \in BV(\mathbb{R}^{n-1}; [0, \infty))$ , and let  $\{G_h\}_{h \in I}$  be an at most countable Borel partition of  $\{v > 0\}$ . We say that  $\{G_h\}_{h \in I}$  is a  $v$ -admissible partition of  $\{v > 0\}$ , if  $\{G_h \cap B_R \cap \{v > \delta\}\}_{h \in I}$  is a Caccioppoli partition of  $\{v > \delta\} \cap B_R$ , for every  $\delta > 0$  such that  $\{v > \delta\}$  is of finite perimeter and for every  $R > 0$ .*

We are now ready to introduce a property that turns out to be equivalent to rigidity, when  $v$  is a special function of bounded variation with locally finite jump set.

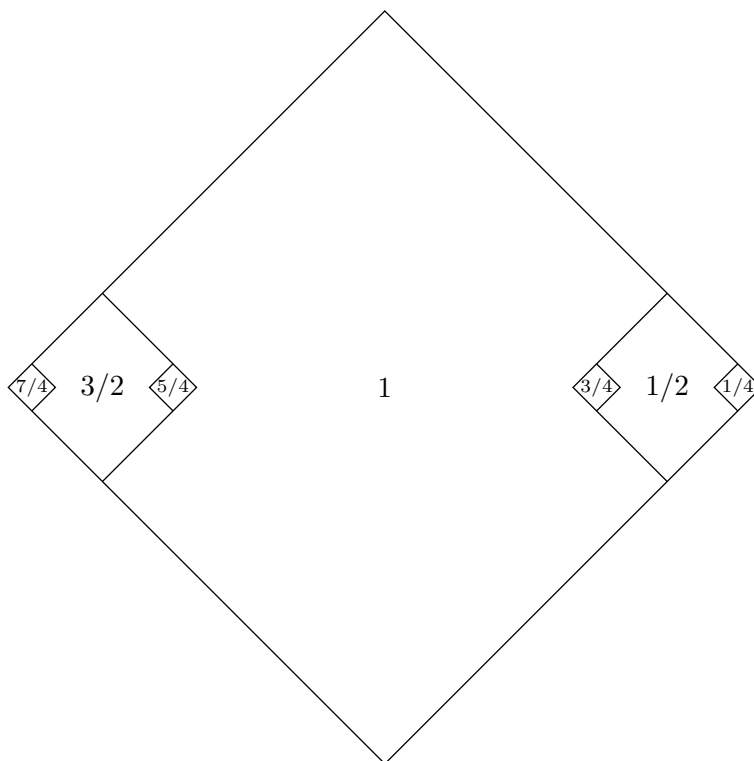

FIGURE 3.11. The level sets of the function  $u_3$  in Example 3.24.

**Definition 3.27.** Let  $v \in BV(\mathbb{R}^{n-1}; [0, \infty))$ . We say that  $v$  satisfies the mismatched stairway property if the following holds: If  $\{G_h\}_{h \in I}$  is a  $v$ -admissible partition of  $\{v > 0\}$  and if  $\{c_h\}_{h \in I} \subset \mathbb{R}$  is a sequence with  $c_h \neq c_k$  whenever  $h \neq k$ , then there exist  $h_0, k_0 \in I$  with  $h_0 \neq k_0$ , and a Borel set  $\Sigma$  with

$$\Sigma \subset \partial^e G_{h_0} \cap \partial^e G_{k_0} \cap \{v^\wedge > 0\}, \quad \mathcal{H}^{n-2}(\Sigma) > 0, \quad (3.16)$$

such that

$$[v](z) < 2|c_{h_0} - c_{k_0}|, \quad \forall z \in \Sigma. \quad (3.17)$$

**Remark 3.28.** The mismatched stairway property rules out the possibility of a counterexample as the one given in Example 3.24. One can check that this property implies condition (ii) of Theorem 3.22 and, in turn, condition (iii) of Theorem 3.18. The interested reader can find more information about this in [10, Remark 1.27 and Remark 1.28].

The following result gives a geometric characterization of rigidity in a very general setting, when  $v$  is a special function of bounded variation with locally finite jump set.

**Theorem 3.29.** Let  $v : \mathbb{R}^{n-1} \rightarrow [0, \infty]$  be a measurable function satisfying (1.5). If, in addition,  $v \in SBV(\mathbb{R}^{n-1}; [0, \infty))$  and  $S_v \cap \{v^\wedge > 0\}$  is locally  $\mathcal{H}^{n-2}$ -finite, then the following are equivalent:

- (i) (SR) holds true;
- (ii)  $v$  has the mismatched stairway property.

We conclude this section with a complete geometric characterization of rigidity in dimension 2, which can be proved due to the simple topology of the real line (see [10, Theorem 1.30]).

**Theorem 3.30.** Let  $n = 2$  and let  $v : \mathbb{R} \rightarrow [0, \infty]$  be a measurable function satisfying (1.5). Then, the following are equivalent:

- (i) (SR) holds true;
- (ii)  $\{v > 0\}$  is  $\mathcal{H}^1$ -equivalent to a bounded open interval  $(a, b)$ ,  $v \in W^{1,1}(a, b)$ , and  $v^\wedge > 0$  on  $(a, b)$ ;
- (iii)  $F_v$  is indecomposable set that has no vertical boundary above  $\{v^\wedge > 0\}$ , i.e.

$$\mathcal{H}^1(\{(x', y) \in \partial^* F_v : \nu_y^{F_v}(x', y) = 0, v^\wedge(x') > 0\}) = 0.$$

#### 4. CHARACTERIZATION OF (ER)

In this section we give a complete characterization of rigidity in the Gaussian setting. We start by giving some information about epigraphs of locally finite perimeter. We stress the fact that we need to consider epigraphs of functions with values in extended real numbers. Indeed, the Ehrhard's symmetral  $F_{\gamma, w}$  associated to a given measurable function  $w : \mathbb{R}^{n-1} \rightarrow [0, 1]$  is the supergraph of a function that might take the values  $+\infty$  (when  $w = 1$ ) and  $-\infty$  (when  $w = 0$ ).

**4.1. Epigraphs of locally finite perimeter and the space  $GBV_*$ .** For any measurable function  $f : \mathbb{R}^{n-1} \rightarrow \mathbb{R} \cup \{\pm\infty\}$ , we denote the epigraph of  $f$  by

$$\Sigma_f := \{x = (x', y) \in \mathbb{R}^n : y > f(x')\}.$$

We are going to discuss under which conditions  $\Sigma_f$  is a set of locally finite perimeter. To this aim, we introduce the following function space. We say that a Lebesgue measurable function  $f : \mathbb{R}^{n-1} \rightarrow \mathbb{R} \cup \{\pm\infty\}$  is a *function of generalized bounded variation with values in extended real numbers*,  $f \in GBV_*(\mathbb{R}^{n-1})$ , if  $\tau_M(f) \in BV_{loc}(\mathbb{R}^{n-1})$  for every  $M > 0$  (recall (2.7)), or, equivalently, if  $\psi(f) \in BV_{loc}(\mathbb{R}^{n-1})$  for every  $\psi \in C^1(\mathbb{R})$  with  $\psi' \in C_c^0(\mathbb{R})$ . In the definition above, we used the convention

$$\psi(+\infty) := \lim_{t \rightarrow +\infty} \psi(t) \quad \text{and} \quad \psi(-\infty) := \lim_{t \rightarrow -\infty} \psi(t).$$

The importance of the space  $GBV_*(\mathbb{R}^{n-1})$  is given by the following proposition (see [11, Proposition 3.1]).

**Proposition 4.1.** *If  $f : \mathbb{R}^{n-1} \rightarrow \mathbb{R} \cup \{\pm\infty\}$  is Lebesgue measurable, then  $f \in GBV_*(\mathbb{R}^{n-1})$  if and only if  $\Sigma_f$  is of locally finite perimeter in  $\mathbb{R}^n$ ; moreover, in this case, for a.e.  $t \in \mathbb{R}$ , we have that  $\{f < t\}$  is a set of locally finite perimeter in  $\mathbb{R}^{n-1}$ .*

**Remark 4.2.** *Note that  $E \subset \mathbb{R}^n$  is a set of locally finite perimeter in  $\mathbb{R}^n$  if and only if  $E$  is a set of locally finite Gaussian perimeter.*

In the following, we will make the minimal assumption on  $w$  that  $P_\gamma(F_{\gamma, w}) < \infty$ , so that the rigidity problem makes sense. By Proposition 4.1, this in particular implies that the Lebesgue measurable function  $\Psi \circ v : \mathbb{R}^{n-1} \rightarrow \mathbb{R} \cup \{\pm\infty\}$  belongs to  $GBV_*(\mathbb{R}^{n-1})$ .

**4.2. Characterization of (ER).** We can now state a complete characterization of rigidity for Ehrhard's inequality.

**Theorem 4.3.** *If  $w : \mathbb{R}^{n-1} \rightarrow [0, 1]$  is a Lebesgue measurable function such that  $P_\gamma(F_{\gamma, w}) < \infty$ , then the following two statements are equivalent:*

- (i) (ER) holds true;
- (ii) the set  $\{w^\wedge = 0\} \cup \{w^\vee = 1\}$  does not essentially disconnect  $\{0 < w < 1\}$ .

Despite the simplicity of the statement above, the proof of Theorem 4.3 is very long and technical. We refer the reader to [11, Theorem 1.3] for more details. In dimension  $n = 2$ , the topology of the real line allows to give an easier characterization of rigidity (see [11, Theorem 1.6]).

**Theorem 4.4.** *Let  $n = 2$ , and let  $w : \mathbb{R} \rightarrow [0, 1]$  be a Lebesgue measurable function such that  $P_\gamma(F_{\gamma, w}) < \infty$ . Then the following two statements are equivalent:*



- (i) (ER) holds true;
- (ii)  $\{0 < w < 1\}$  is  $\mathcal{H}^1$ -equivalent to an open interval  $I$ , with  $0 < w^\wedge$  and  $w^\vee < 1$  on  $I$ .

The statements above might suggest that an equivalent condition for rigidity in the Gauss space might be that both  $F_{\gamma,w}$  and its complement  $\mathbb{R}^n \setminus F_{\gamma,w}$  are indecomposable. In dimension  $n = 2$  it turns out that if both  $F_{\gamma,w}$  and  $\mathbb{R}^n \setminus F_{\gamma,w}$  are indecomposable, then (ER) holds true (see [11, Theorem 4.2]). The opposite implication, however, is false, see Figure 4.1. In dimension higher than 2 instead, even if both  $F_{\gamma,w}$  and  $\mathbb{R}^n \setminus F_{\gamma,w}$  are

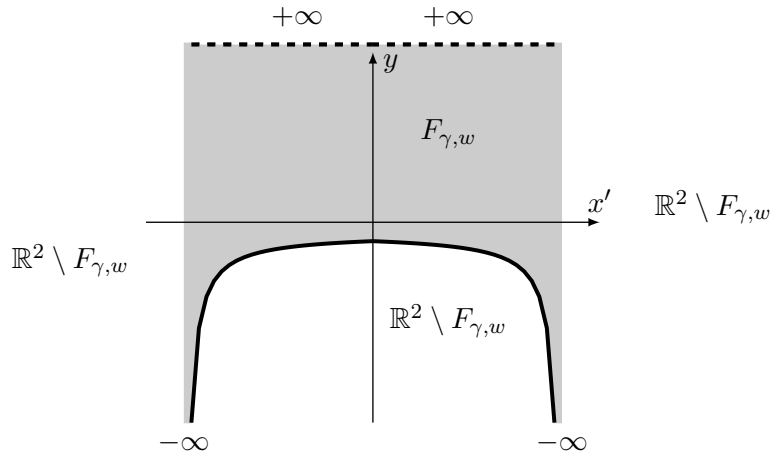

FIGURE 4.1. Rigidity (ER) holds true, but  $\mathbb{R}^2 \setminus F_{\gamma,w}$  is decomposable.

indecomposable, it might happen that (ER) fails. We direct the interested reader to [11, Remark 1.7] for a more detailed discussion.

## 5. OPEN PROBLEMS

The results highlighted in this paper show that the theory of rigidity for symmetrization inequalities is quite rich. We would now like to mention some of the several problems that are still open. First of all, it is well known that Steiner's inequality is also true when one considers the Steiner symmetrization in codimension  $k \in \mathbb{N}$ , with  $1 \leq k \leq n - 1$  (see, for instance, [5, Theorem 1.1]). In this context, sufficient conditions for rigidity are proved in [5, Theorem 1.2], in the spirit of Theorem 3.6, but no characterizations are known. Note that solving this problem might require to tackle very delicate coarea regularity issues, which are peculiar of the case of codimension larger than 1 (see, [5, Remark 3.2]). Using a suitable version of Ehrhard's symmetrization, one can also consider the analogous problem in higher codimension for the Gaussian setting. In this case, it is not clear whether the notion of essential connectedness will allow a complete and simple characterization of rigidity, as in Theorem 4.3.

Another important problem is the study of rigidity for Pólya-Szegő inequality. We recall that Pólya-Szegő inequality states that the  $L^p$  norm of the gradient of a Sobolev function does not increase under spherically symmetric rearrangement. More precisely, if  $n \in \mathbb{N}$  and  $n \geq 2$ ,  $p \geq 1$ :

$$\|\nabla u^*\|_{L^p(\mathbb{R}^{n-1})} \leq \|\nabla u\|_{L^p(\mathbb{R}^{n-1})} \quad \text{for every } u \in W^{1,p}(\mathbb{R}^{n-1}; [0, \infty)). \quad (5.1)$$

Here,  $u^*$  is the Sobolev function whose subgraph is obtained by considering the  $((n - 1)$ -codimensional) Steiner symmetrisation of the subgraph of  $u$ . Extremals of (5.1) were firstly studied in [27] (see also [26]). After that, Brothers and Ziemer [9] and Cianchi and Fusco [16] gave sufficient conditions for rigidity, in the class of Sobolev and BV functions, respectively. Still sufficient conditions were given by Cianchi and Fusco in codimension 1 [17],

and by Capriani in codimension greater than 1 [13]. To date, a characterization of rigidity for (5.1) is still missing.

## 6. ACKNOWLEDGEMENTS

The author would like to thank Francesco Maggi for interesting discussions on the subject. The author was supported by the EPSRC under the Grant EP/P007287/1 “Symmetry of Minimisers in Calculus of Variations”.

## REFERENCES

- [1] L. AMBROSIO, V. CASELLES, S. MASNOU, AND J. MOREL, *Connected components of sets of finite perimeter and applications to image processing*, J. Eur. Math. Soc. (JEMS), 3 (2001), pp. 39–92.
- [2] L. AMBROSIO, N. FUSCO, AND D. PALLARA, *Functions of bounded variation and free discontinuity problems*, Oxford Mathematical Monographs, The Clarendon Press, Oxford University Press, New York, 2000.
- [3] D. BAKRY AND M. LEDOUX, *Lévy-Gromov isoperimetric inequality for an infinite dimensional diffusion generator*, Invent. Math., 123 (1995), pp. 259–281.
- [4] M. BARCHIESI, A. BRANCOLINI, AND V. JULIN, *Sharp dimension free quantitative estimates for the Gaussian isoperimetric inequality*, Ann. Probab., 45 (2017), pp. 668–697.
- [5] M. BARCHIESI, F. CAGNETTI, AND N. FUSCO, *Stability of the Steiner symmetrization of convex sets*, J. Eur. Math. Soc., 15 (2013), pp. 1245–1278.
- [6] F. BARTHE AND B. MAUREY, *Some remarks on isoperimetry of Gaussian type*, Ann. Inst. H. Poincaré Probab. Statist., 36 (2000), pp. 419–434.
- [7] S. G. BOBKOV, *An isoperimetric inequality on the discrete cube, and an elementary proof of the isoperimetric inequality in Gauss space*, Ann. Probab., 25 (1997), pp. 206–214.
- [8] C. BORELL, *The Brunn-Minkowski inequality in Gauss space*, Invent. Math., 30 (1975), pp. 207–216.
- [9] J. E. BROTHERS AND W. P. ZIEMER, *Minimal rearrangements of Sobolev functions*, J. Reine Angew. Math., 384 (1988), pp. 153–179.
- [10] F. CAGNETTI, M. COLOMBO, G. DE PHILIPPIS, AND F. MAGGI, *Rigidity of equality cases in Steiner’s perimeter inequality*, Anal. PDE, 7 (2014), pp. 1535–1593.
- [11] ———, *Essential connectedness and the rigidity problem for Gaussian symmetrization*, J. Eur. Math. Soc. (JEMS), 19 (2017), pp. 395–439.
- [12] F. CAGNETTI, M. PERUGINI, AND D. STÖGER, *Rigidity for perimeter inequality under spherical symmetrisation* (in preparation), (2018).
- [13] G. M. CAPRIANI, *The Steiner rearrangement in any codimension*, Calc. Var. Partial Differential Equations, 49 (2014), pp. 517–548.
- [14] E. A. CARLEN AND C. KERCE, *On the cases of equality in Bobkov’s inequality and Gaussian rearrangement*, Calc. Var. Partial Differential Equations, 13 (2001), pp. 1–18.
- [15] M. CHLEBÍK, A. CIANCHI, AND N. FUSCO, *The perimeter inequality under Steiner symmetrization: cases of equality*, Ann. of Math. (2), 162 (2005), pp. 525–555.
- [16] A. CIANCHI AND N. FUSCO, *Functions of bounded variation and rearrangements*, Arch. Ration. Mech. Anal., 165 (2002), pp. 1–40.
- [17] ———, *Steiner symmetric extremals in Pólya-Szegő type inequalities*, Adv. Math., 203 (2006), pp. 673–728.
- [18] A. CIANCHI, N. FUSCO, F. MAGGI, AND A. PRATELLI, *On the isoperimetric deficit in Gauss space*, Amer. J. Math., 133 (2011), pp. 131–186.
- [19] E. DE GIORGI, *Sulla proprietà isoperimetrica dell’ipersfera, nella classe degli insiemi aventi frontiera orientata di misura finita*, Atti Accad. Naz. Lincei. Mem. Cl. Sci. Fis. Mat. Nat. Sez. I (8), 5 (1958), pp. 33–44.
- [20] ———, *Selected papers*, Springer Collected Works in Mathematics, Springer, Heidelberg, 2013. [Author name on title page: Ennio Giorgi], Edited by Luigi Ambrosio, Gianni Dal Maso, Marco Forti, Mario Miranda and Sergio Spagnolo, Reprint of the 2006 edition.
- [21] G. DOLZMANN AND S. MÜLLER, *Microstructures with finite surface energy: the two-well problem*, Arch. Rational Mech. Anal., 132 (1995), pp. 101–141.
- [22] A. EHRHARD, *Symétrisation dans l’espace de Gauss*, Math. Scand., 53 (1983), pp. 281–301.
- [23] ———, *Inégalités isopérimétriques et intégrales de Dirichlet gaussiennes*, Ann. Sci. École Norm. Sup. (4), 17 (1984), pp. 317–332.
- [24] ———, *Éléments extrémaux pour les inégalités de Brunn-Minkowski gaussiennes*, Ann. Inst. H. Poincaré Probab. Statist., 22 (1986), pp. 149–168.

- [25] M. GIAQUINTA, G. MODICA, AND J. SOUCEK, *Cartesian currents in the Calculus of Variations. I. Cartesian currents*, vol. 37 of *Ergebnisse der Mathematik und ihrer Grenzgebiete. 3. Folge. A Series of Modern Surveys in Mathematics*, Springer-Verlag, Berlin, 1998.
- [26] B. KAWOHL, *Rearrangements and convexity of level sets in PDE*, vol. 1150 of *Lecture Notes in Mathematics*, Springer-Verlag, Berlin, 1985.
- [27] ———, *On the isoperimetric nature of a rearrangement inequality and its consequences for some variational problems*, *Arch. Rational Mech. Anal.*, 94 (1986), pp. 227–243.
- [28] M. LEDOUX, *A short proof of the Gaussian isoperimetric inequality*, in *High dimensional probability (Oberwolfach, 1996)*, vol. 43 of *Progr. Probab.*, Birkhäuser, Basel, 1998, pp. 229–232.
- [29] F. MAGGI, *Sets of finite perimeter and geometric variational problems*, vol. 135 of *Cambridge Studies in Advanced Mathematics*, Cambridge University Press, Cambridge, 2012. An introduction to Geometric Measure Theory.
- [30] M. PERUGINI, *Rigidity of equality cases in Steiner’s anisotropic perimeter inequality* (in preparation), (2018).
- [31] V. N. SUDAKOV AND B. S. CIREL’SON, *Extremal properties of half-spaces for spherically invariant measures*, *Zap. Naučn. Sem. Leningrad. Otdel. Mat. Inst. Steklov. (LOMI)*, 41 (1974), pp. 14–24, 165. *Problems in the theory of probability distributions, II*.
- [32] A. I. VOL’PERT, *Spaces BV and quasilinear equations*, *Mat. Sb. (N.S.)*, 73 (115) (1967), pp. 255–302.

DEPARTMENT OF MATHEMATICS, UNIVERSITY OF SUSSEX, PEVENSEY 2, BN1 9QH, BRIGHTON, UK  
*E-mail address:* `f.cagnetti@sussex.ac.uk`